

**OPERATOR'S, UNIT AND DIRECT SUPPORT  
MAINTENANCE MANUAL  
(INCLUDING REPAIR PARTS AND  
SPECIAL TOOLS LIST)**

**CONTAINERIZED SELF SERVICE LAUNDRY  
(CSSL)  
MODEL B  
NSN 3510-01-485-0457**

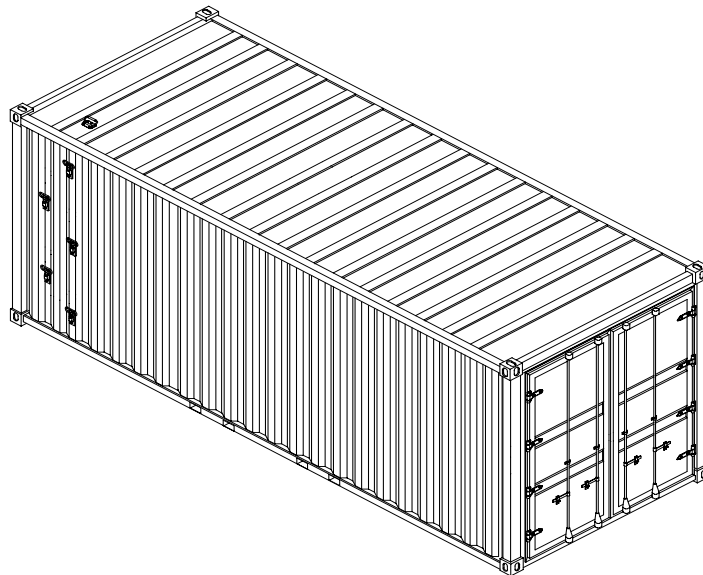

DISTRIBUTION STATEMENT A: Approved for public release; distribution is unlimited.

---

**HEADQUARTERS, DEPARTMENT OF THE ARMY**

**30 SEPTEMBER 2002**

THIS PAGE INTENTIONALLY LEFT BLANK

## WARNING SUMMARY

This warning summary contains general safety warnings and hazardous materials warnings that must be understood and applied during operation of this equipment. Failure to observe these precautions could result in serious injury or death to personnel. Also included are explanations of safety and hazardous materials icons used within this technical manual.

### EXPLANATION OF SAFETY WARNING ICONS



HEAVY OBJECT - human figure stooping over heavy object shows physical injury potential from improper lifting technique



SHARP OBJECT – pointed object in hand shows that a sharp object presents a danger to limb.



ELECTRICAL - electrical wire to arm with electricity symbol running through human body shows that shock hazard is present



HEAVY PARTS - heavy object on human figure shows that heavy parts present a danger to life or limb.



BIOLOGICAL - abstract symbol bug shows that a material may contain bacteria or viruses that present a danger to life or health.



SLICK FLOOR – wavy line on floor with legs prone shows that slick floor presents a danger of falling.



POISON – skull and crossbones shows that a material is poisonous or is a danger to life.

### GENERAL SAFETY WARNINGS DESCRIPTION

#### **WARNING** **Two Person Lift**



Some CSSL components are heavy. Applicable warnings and instructions are contained in the set-up and maintenance procedures, calling for the required number of persons needed to lift these components. To prevent injuries, ensure that the required number of people is on hand for the lift. Be sure to lift with legs, not back, to prevent injury.

#### **WARNING** **Cut Hazard**



During some maintenance procedures, electrical wires must be cut and some metal parts of the CSSL may have sharp edges. Be careful when handling and assembling the CSSL components to prevent injuries.

**WARNING**

**Electrical Shock**



The CSSL equipment operates at high voltages. Use extreme caution. Touching a live wire can cause serious injury or death. Only military personnel in MOS 51R, 52C, 52D or 52G or a qualified civilian can connect the power supply to the CSSL. Follow warnings contained in the operational and maintenance procedures to prevent serious injuries to personnel.

**WARNING**

**Heavy Equipment**



The CSSL container weighs approximately 10,000 pounds when packed. Lift and move the container only with material handling equipment of at least 10,000 pounds capacity. Observe all safety precautions. Never stand under a CSSL container when it is being lifted. Unpacking components requires at least two persons.

**WARNING**

**Contamination Hazard**



Ensure that wastewater is properly disposed of either through an approved municipal sewage system, or collected using a 3,000 Gallon tank, with subsequent evacuation by tanker. Keep wastewater hoses away from freshwater hoses and any freshwater supply in the vicinity. Serious health problems may result from water contamination.

**WARNING**

**Tripping Hazard**



Eliminate the possibility of tripping. Clear fabric and guy lines. Injury to personnel may result from falls.

**WARNING**

**Poison Hazard**



The Containerized Self Service Laundry is shipped with an anti-freeze solution pumped into the freshwater lines. The anti-freeze solution is non-toxic but is unsuitable for drinking or washing. DO NOT OPERATE THE CSSL until the freshwater lines have been flushed.



INSERT LATEST UPDATED PAGES / WORK PACKAGES DESTROY SUPERSEDED DATA

**LIST OF EFFECTIVE PAGES**

Note: The portion of text affected by the update is indicated by a vertical line in the outer margins of the page. Updates to illustrations are indicated by miniature pointing hands. Updates to wiring diagrams are indicated by shaded areas.

Dates of issue for original and updated pages / work packages are:

Original 30 September 2002

**TOTAL NUMBER OF PAGES FOR FRONT AND REAR MATTER IS 24 AND TOTAL NUMBER OF WORK PACKAGES IS 72 CONSISTING OF THE FOLLOWING:**

<b>Page / WP</b>	<b>*Revision</b>	<b>Page / WP</b>	<b>*Revision</b>
<b>No.</b>	<b>No.</b>	<b>No.</b>	<b>No.</b>
Front Cover	0		
Title	0		
Warning	0		
a-b	0		
A-B	0		
i -vi	0		
WP 0001-0070	0		
Index 1 – 4	0		
Sample DA Form 2028	0		
Blank DA Form 2028	0		
Back Cover	0		

**\*Zero in this column indicates an original page or work package**

**A/(B Blank)**

THIS PAGE INTENTIONALLY LEFT BLANK

HEADQUARTERS,  
DEPARTMENT OF THE ARMY  
WASHINGTON, D.C., 31 JULY 2002

TECHNICAL MANUAL

**OPERATOR’S, UNIT AND DIRECT SUPPORT MAINTENANCE MANUAL  
(INCLUDING REPAIR PARTS AND SPECIAL TOOLS LISTS)**

**CONTAINERIZED SELF SERVICE LAUNDRY (CSSL)  
MODEL B  
(NSN 3510-01-485-0457)**

You can help improve this manual. If you find any mistakes or if you know of a way to improve the procedures, please let us know. Mail your letter together with DA Form 2028 (Recommended Changes to Publications and Blank Forms), located in the back of this manual, directly to: Commander, U.S. Army Soldier and Biological Chemical Command, ATTN: AMSSB-RIM-L(N), Kansas Street, Natick, MA 01760-5052. You may also send in your recommended changes via electronic mail directly to amssbriml@natick.army.mil. A reply will be furnished to you. Instructions for sending an electronic 2028 may be found at the back of this manual immediately preceding the hard copy 2028.

**DISTRIBUTION STATEMENT A:** Approved for public release; distribution is unlimited.

**TABLE OF CONTENTS**

	<b>WP Sequence No.</b>
<b>WARNING SUMMARY</b>	<b>a</b>
<b>LIST OF EFFECTIVE PAGES</b>	<b>A</b>
<b>HOW TO USE THIS MANUAL</b>	<b>v</b>
 <b>GENERAL INFORMATION</b>	
Scope .....	0001 00
Maintenance Forms, Records, and Reports.....	0001 00
Reporting Equipment Improvement Recommendations (EIRS).....	0001 00
Corrosion Prevention and Control (CPC).....	0001 00
Destruction of Army Materiel to Prevent Enemy Use .....	0001 00
Nomenclature Cross-Reference List .....	0001 00
List of Abbreviations/Acronyms .....	0001 00
Safety, Care and Handling, Warnings, Cautions and Notes .....	0001 00

**TABLE OF CONTENTS – Continued**

<b>CHAPTER 1 - DESCRIPTION AND THEORY OF OPERATION</b>	<b>WP Sequence No.</b>
Equipment Characteristics, Capabilities and Features.....	0002 00
Clothing Weight.....	0002 00
Location and Description of Major Components.....	0002 00
Description of System Components.....	0002 00
Common Tools and Equipment.....	0002 00
Equipment Data.....	0002 00
References.....	0002 00
Theory of Operation.....	0003 00
CSSL Minimum Employment Conditions.....	0003 00
 <b>CHAPTER 2 - OPERATOR INSTRUCTIONS</b>	
Controls and Indicators.....	0004 00
Labels and Instruction Plates.....	0004 00
Siting Requirements.....	0005 00
Site Selection.....	0005 00
Unpacking and Inventory of CSSL Components.....	0005 00
Prepare Power Distribution System for Use.....	0005 00
Set Up Water System External Components.....	0005 00
Prepare Washers and Water System for use.....	0005 00
Prepare Dryers and Drying System for use.....	0005 00
Prepare TEMPER with Modified End Section for use.....	0005 00
Operate CSSL.....	0005 00
CSSL Temporary Shutdown.....	0005 00
Prepare CSSL for Return Shipment.....	0005 00
Prepare Washers and Dryers for Shipment.....	0005 00
Prepare Freshwater Components for Shipment.....	0005 00
Prepare Wastewater Components for Shipment.....	0005 00
Prepare TEMPER with Modified End Section for Shipment.....	0005 00
Prepare Power Distribution System for Shipment.....	0005 00
Packing CSSL for Return Shipment.....	0005 00
Operation Under Unusual Environment/Weather Conditions.....	0006 00
 <b>CHAPTER 3 - OPERATOR TROUBLESHOOTING AND SERVICE PROCEDURES</b>	
Lubrication Requirements.....	0007 00
Troubleshooting Procedures.....	0008 00
Malfunction Symptom Index.....	0008 00
Operator Troubleshooting Procedures.....	0008 00

**TABLE OF CONTENTS - Continued**

<b>CHAPTER 4 - OPERATOR MAINTENANCE INSTRUCTIONS</b>	<b>WP Sequence No.</b>
Preventive Maintenance Checks and Services (PMCS) .....	0009 00
Operator Maintenance.....	0010 00
 <b>CHAPTER 5 - UNIT MAINTENANCE INSTRUCTIONS</b>	
Service Upon Receipt.....	0011 00
Troubleshooting Procedures .....	0012 00
Malfunction Symptom Index .....	0012 00
Unit Troubleshooting Procedures .....	0012 00
Power Entry Connectors .....	0013 00
Power Distribution Panel .....	0014 00
Fluorescent Lights .....	0015 00
Interior Switches and Receptacles .....	0016 00
Freshwater Pump and Internal Freshwater Line .....	0017 00
Pressure Tank .....	0018 00
Pressure Switch/Gauge.....	0019 00
Sump Pump and Float Switch .....	0020 00
Wastewater PVC Pipes .....	0021 00
Washers/Dryers.....	0022 00
Vent Fan.....	0023 00
Space Heater .....	0024 00
Water Hoses.....	0025 00
CSSL Modified End Section .....	0026 00
Roofgrip.....	0027 00
 <b>CHAPTER 6 - DIRECT SUPPORT MAINTENANCE INSTRUCTIONS</b>	
Troubleshooting Procedures .....	0028 00
Malfunction Symptom Index .....	0028 00
Direct Support Troubleshooting Procedures .....	0028 00
Modified Folding Steps .....	0029 00
Power Entry Connectors .....	0030 00
Power Distribution Panel .....	0031 00
Fluorescent Lights .....	0032 00
Freshwater Pump and Internal Freshwater Line .....	0033 00
Pressure Tank .....	0034 00
Pressure Switch and Gauge.....	0035 00
Sump Pump.....	0036 00
Wastewater PVC Pipes .....	0037 00
Washer/Dryer .....	0038 00
Vent Fan .....	0039 00
Space Heater .....	0040 00

**TABLE OF CONTENTS - Continued**

<b>CHAPTER 7 - SUPPORTING INFORMATION</b>	<b>WP Sequence No.</b>
References.....	0041 00
Maintenance Allocation Chart .....	0042 00
Introduction to Repair Parts and Special Tools List .....	0043 00
Repair Parts and Special Tools List-Group 01 Cargo Container.....	0044 00
Repair Parts and Special Tools List-Group 0101 Modified Folding Steps .....	0045 00
Repair Parts and Special Tools List-Group 0201 Power Entry Connectors .....	0046 00
Repair Parts and Special Tools List-Group 0202 Power Distribution Panel.....	0047 00
Repair Parts and Special Tools List-Group 0203 Fluorescent Lights.....	0048 00
Repair Parts and Special Tools List-Group 0204 Interior Switches/Receptacles.....	0049 00
Repair Parts and Special Tools List-Group 0205 Exterior Power Cables .....	0050 00
Repair Parts and Special Tools List-Group 0301 Freshwater Pump and Internal Freshwater Line.....	0051 00
Repair Parts and Special Tools List-Group 0302 Pressure Tank.....	0052 00
Repair Parts and Special Tools List-Group 0303 Pressure Switch/Gauge .....	0053 00
Repair Parts and Special Tools List-Group 0401 Sump Pump .....	0054 00
Repair Parts and Special Tools List-Group 0402 Float Switch .....	0055 00
Repair Parts and Special Tools List-Group 0403 Wastewater PVC Pipes .....	0056 00
Repair Parts and Special Tools List-Group 05 Washer/Dryer.....	0057 00
Repair Parts and Special Tools List-Group 06 Vent Fan .....	0058 00
Repair Parts and Special Tools List-Group 07 TEMPER.....	0059 00
Repair Parts and Special Tools List-Group 08 Space Heater.....	0060 00
Repair Parts and Special Tools List-Group 09 3,000 Gallon Tank.....	0061 00
Repair Parts and Special Tools List-Group 10 Water Hoses.....	0062 00
Repair Parts and Special Tools List-Group 11 CSSL Modified End Section .....	0063 00
Bulk Material Repair Parts List.....	0064 00
National Stock Number Index.....	0065 00
Special Tools List .....	0066 00
Part Number Index .....	0067 00
Components of End Item (COEI) List and Basic Issue Items (BII) List.....	0068 00
Additional Authorization List.....	0069 00
Expendable and Durable Items List .....	0070 00
Mandatory Replacement Parts List .....	0071 00
Illustrated List of Manufactured Items.....	0072 00
<b>ALPHABETICAL INDEX .....</b>	<b>INDEX 1</b>

## HOW TO USE THIS MANUAL

This Manual contains General Information, Operating Instructions, Operator Preventive Maintenance Checks and Services (PCMS), Troubleshooting, and Maintenance/Repair instructions for the Containerized Self Service Laundry (CSSL).

Chapter 1 contains introductory information on the CSSL and its associated equipment as well as a Theory of Operation. Chapter 2 includes operating instructions under usual and unusual conditions. Chapter 3 contents include operator troubleshooting, PMCS, and service procedures. Chapter 4 contains Unit Maintenance instructions. Chapter 5 contains Unit Maintenance instructions as well as troubleshooting procedures. Chapter 6 contains references and other supporting information. Chapter 7 includes the Repair Parts and Special Tools List (RPSTL) that identifies those parts or tools that are unique to the operation and maintenance of this equipment.

**Manual Organization and Page Numbering System.** The Manual is divided into seven major chapters that detail the topics mentioned above. Within each chapter are work packages covering a wide range of topics. Each work package is numbered sequentially starting at page 1. The work package has its own page numbering scheme and is independent of the page numbering used by other work packages. Each page of a work package has a page number of the form XXXX YY-ZZ where XXXX is the work package number (e.g. 0010 is work package 10) and YY is the revision number for that work package and ZZ represents the number of the page within that work package. A page number such as 0010 00-1/2 blank means that page 1 contains information but page 2 of that work package has been intentionally left blank.

**Finding Information.** The Table of Contents permits the reader to find information in the manual quickly. The reader should start here first when looking for a specific topic. The Table of Contents lists the topics contained within each chapter and the Work Package Sequence Number where it can be found.

Example: If the reader were looking for instructions on "Preventive Maintenance Checks and Services", which is a Operator Maintenance topic, the Table of Contents indicates that Operator Maintenance information can be found in Chapter 3. Scanning down the listings for Chapter 3, "Preventive Maintenance Checks and Services" information can be found in WP 0010 00 (i.e. Work Package 10).

An Alphabetical Index can be found at the back of the Manual, and lists specific topics with the corresponding work package.

THIS PAGE INTENTIONALLY LEFT BLANK



---

**CONTAINERIZED SELF SERVICE LAUNDRY (CSSL)  
NSN 3510-01-485-0457  
GENERAL INFORMATION**

---

**SCOPE.**

This Technical Manual contains instructions for the operation, as well as preventive, and corrective maintenance of the Containerized Self Service Laundry (CSSL) (Refer to Figure 1.)

The CSSL is non-organizational equipment and must be requested through Army support channels.

Type of Manual: Operators, Unit, and Direct Support Maintenance, including Repair Parts and Special Tools List.

Model Number and Equipment Name: Containerized Self Service Laundry (CSSL) Model B, P/N 5-13-6637, NSN 3510-01-485-0457.

Purpose of Equipment: The CSSL provides cold-water washing and drying capacity of 10lbs per washer/ dryer. It can support 120 personnel over a 20 Hour operating period. CSSL components can be operated by MOS non-specific personnel, however, initial power connections direct support level maintenance of some components must be accomplished by MOS 51R, 52C, 52D, or 52G qualified personnel.

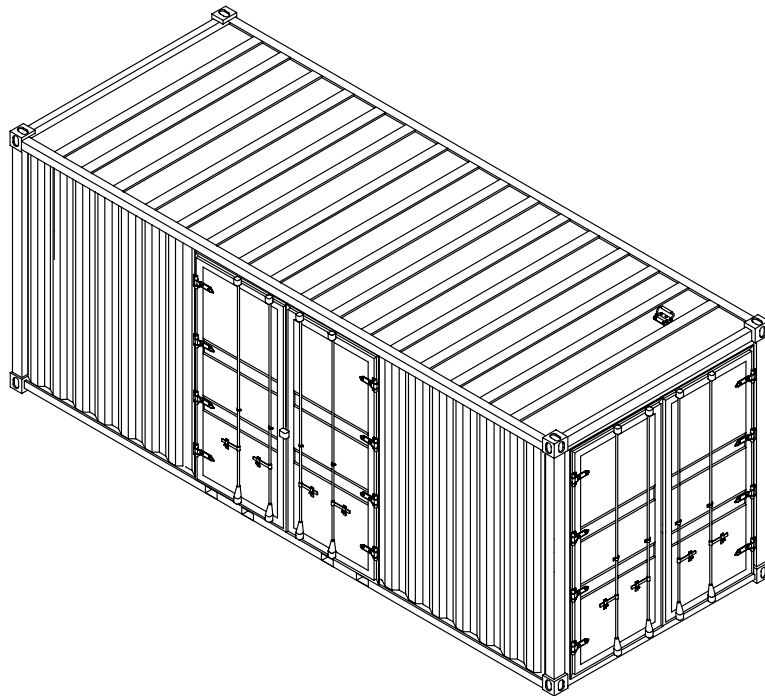

**Containerized Self Service Laundry (Stored Configuration).**

**MAINTENANCE FORMS RECORDS AND REPORTS**

Department of the Army forms and procedures used for equipment maintenance will be those prescribed by DA PAM 738-750, Functional Users Manual for The Army Maintenance Management System (TAMMS) (Maintenance Management Update).

**REPORTING EQUIPMENT IMPROVEMENT RECOMMENDATIONS (EIRs).**

If your CSSL needs improvement, let us know. Send us an EIR. You, the user are the only one who can tell us what you don't like about your equipment. Let us know why you don't like the design or performance. Put it on an SF368 Product Quality Deficiency Report. Mail it to: Commander U.S. Army Soldier and Biological Chemical Command; ATTN: AMSSB-RIM-E(N), Kansas St. Natick, MA 01760-5052. We will send you a reply.

**CORROSION PREVENTION AND CONTROL (CPC).**

Corrosion Prevention and Control (CPC) of Army materiel is a continuing concern. It is important that any corrosion problems with this item be reported so that the problem can be corrected and improvements can be made to prevent the problem in future items.

While corrosion is typically associated with rusting of metals, it can also include deterioration of other materials, such as rubber or plastic. Unusual cracking, softening, swelling or breaking of these materials may be a corrosion problem.

If a corrosion problem is identified, it can be reported using SF 368, Product Quality Deficiency Report. Use of key words such as corrosion, rust, deterioration or cracking will ensure that the information is identified as a CPC problem. This form should be submitted to the address specified in DA Pam 738-750.

**DESTRUCTION OF ARMY MATERIEL TO PREVENT ENEMY USE.**

For procedures to destroy this equipment to prevent its use by the enemy refer to TM 750-244-3, Procedures for Destruction of Material to prevent Enemy use.

**NOMENCLATURE CROSS-REFERENCE LIST.**

Common Name	Official Name
Bootwall	TEMPER End Section, ISO Modified
Container	Shelter Modified, Welded Assembly, CSSL
CSSL	Containerized Self Service Laundry Model B
Freshwater hose	Hose Assembly, Fresh Water, 2"
Pressure tank	Tank pre-pressurized, diaphragm type
Tent	TEMPER, Section, Window
Wastewater hose	Hose Assembly, Discharge, Waste Water, 2"
Water Pump	Water Pump, 30gpm (Freshwater)
Washer/Dryer	Maytag Stacked Washer/Dryer Units
Sump pump	Teel Simplex Sewage Package System

**LIST OF ABBREVIATIONS/ACRONYMS.**

AAL	Additional Authorization List	MOS	Military Occupational Specialty
AMP	Amperage	MSDS	Material Safety Data Sheet
BII	Basic Issue Item	MTOE	Modified Table of Org and Equipment
COEI	Component of end item	NBC	Nuclear, Biological, Chemical
CPC	Corrosion Prevention Control	NIIN	National Item Identification Number
CSSL	Containerized Self Service Laundry	NSN	National Stock Number
cm	Centimeter	P/N	Part Number
°C	Degrees Celsius (Centigrade)	POL	Petroleum, Oil and Lubricant
°F	Degrees Fahrenheit	PMCS	Preventive Maintenance Checks and Services
EIR	Equipment Improvement Recommendation	PSI	Pounds per square inch
GFCI	Ground Fault Circuit Interrupt	QD	Quick Disconnect
GPM	Gallons per Minute	RCPT	Receptacle
hr	Hour	RPSTL	Repair Parts and Special Tools List
IAW	In Accordance With	SMR	Source, Maintenance, and Recoverability
ISO	International Organization for Standardization	TMDE	Test, Measurement, Diagnostic Equipment
in	Inches	TOE	Table of Organization and Equipment
kg	Kilogram	U/M	Unit of Measure
kW	Kilowatt	UOC	Usable On Code
lbs	Pounds	VAC	Volt Alternating Current
l	Liter	WP	Work Package

**SAFETY, CARE AND HANDLING, WARNINGS, CAUTIONS AND NOTES.**

Always pay attention to Warnings, Cautions and Notes appearing throughout the manual. They will appear prior to applicable procedures. Ensure you read and understand their content to prevent serious injury to yourself and others, or damage to equipment.

**END OF WORK PACKAGE**

THIS PAGE INTENTIONALLY LEFT BLANK

**TM 10-3510-224-13&P**

**CHAPTER 1**  
**DESCRIPTION AND THEORY OF OPERATION**  
**FOR THE**  
**CONTAINERIZED SELF SERVICE LAUNDRY**  
**(CSSL)**  
**MODEL B**

THIS PAGE INTENTIONALLY LEFT BLANK

**CONTAINERIZED SELF SERVICE LAUNDRY (CSSL)  
NSN 3510-01-485-0457  
EQUIPMENT DESCRIPTION AND DATA**

**EQUIPMENT CHARACTERISTICS, CAPABILITIES AND FEATURES.**

<b>Characteristics</b>	<b>Capabilities and Features</b>
<ul style="list-style-type: none"> <li>• The Modular system, whether in a stowed or deployed configuration, includes all the necessary equipment to operate the facility.</li> <li>• Four-person assembly and disassembly, within two hours each.</li> <li>• Provides cold-water washing only.</li> <li>• Suitable for operation in temperatures above 32<sup>o</sup> F.</li> <li>• Washers/dryers are secured to the general cargo container floor and wall for stability during operation and shipment.</li> <li>• Features an 8 Foot TEMPER section (without vestibules). It is attached to the CSSL container using an ISO Modified end section, incorporating a boot that provides a weather-tight fit.</li> </ul>	<ul style="list-style-type: none"> <li>• Provides self-service laundry facilities using commercial washer/dryers.</li> <li>• Provides six individual washer/dryers for washing of personal clothing, each with a capacity of 10 lbs per cycle.</li> <li>• Supports 120 personnel over a 20 Hour operating period.</li> <li>• Container uses utility panels for easy fresh water, wastewater, and electrical power connections.</li> <li>• The CSSL features an internal heater and a vent fan for temperature control and ventilation.</li> <li>• Dryer exhausts are ducted to the outside through an exhaust duct.</li> <li>• The CSSL can be operated by MOS non-specific personnel.</li> </ul>

**Clothing Weight.**

The CSSL washer/dryers are suitable for washing 10 lbs of personal clothing items and uniforms. An example of a 10 lb load consists of one battlefield dress uniform, together with undergarments, socks and a towel.

**LOCATION AND DESCRIPTION OF MAJOR COMPONENTS (Internal).**

**Container.** Modified general cargo container (1) with forklift pockets (2) and ISO fittings (3) for moving and lifting the container. Double doors are located at each end of the container. The personnel door (4) serves as main access door to the CSSL, and the rear door (5) provides access to the utility wall containing a freshwater panel (6), wastewater panel (7), power entry box (8) and vent fan (9). Located inside the container is a freshwater pump (10), wastewater tank (11) and pressure tank (12). An additional double service door (13) on the container side allows access to the rear of the washer/dryers (14). Built-in, hinged steps (15) and a handgrip (16) allow access to the top of the container

**Space Heater.** Installed inside the container at the rear, the heater (17) provides interior heating of the container when the CSSL is not in operation.

**Power Entry Panel.** The Power Entry Panel (8) is located in the utility wall and includes two 208 VAC, 3 Phase input connectors (18) for power supply to both circuit breaker panels right (19) and left (20), a 110 VAC GFCI utility receptacle (21) used for TEMPER interior lights, a 30 AMP twist lock receptacle (22) and a 60 AMP Class L connector (23). A ground terminal (24) is located in the lower right corner of the panel.

**Power Distribution Panel (Right Side) (19).** This panel contains a main breaker, and powers washers/dryers (14) #1 (a), 3 (c) and 5 (e) CSSL interior lights (25), the 60 AMP Class L connector (23), the space heater (17), the sump pump (26), the fresh water pump (10) and the vent fan (9).

**Power Distribution Panel (Left Side) (20)** This panel contains a main breaker, and powers washer/dryers (14) # 2, (b) 4, (d) and 6 (f), as well as the 30 AMP twist lock receptacle (22) and the 110 VAC GFCI utility receptacle (21).

**Freshwater and Wastewater Panels.** The utility wall freshwater supply (6) and wastewater drain panel (7) hose connections facilitate the following connections:

- *Outside CSSL:* Fresh water connection and wastewater connection to external source and disposal point, respectively.
- *Inside CSSL:* Fresh water connection to the fresh water pump, and wastewater connection from the wastewater holding tank.

**CSSL Interior lights and light Switch.** Two fluorescent light fixtures (25) are controlled from the light switch (27) located on the side wall near the personnel door.

**Washers/Dryers #1 thru #6 (a thru f).** The washer/dryers are mounted to the container floor and wall. The power cord of each washer/dryer unit is plugged into a twist-lock receptacle (28) located on the overhead raceway. One fresh water hose (29) connects each washer to the ¾" fresh water supply line (30). Using a standard Y connector. The washer drain hoses (31) are connected to the 3" PVC drain (32).

**Freshwater Pump.** The freshwater pump (10) is mounted onto the container floor and is connected to the fresh water supply panel. It provides fresh water under pressure to the main supply line when a 3,000 Gallon storage tank is used.

**Wastewater Tank and Sump Pump.** The wastewater tank (11) collects wastewater generated by the washers through the 3" PVC drainpipe (32). A sump pump (26) evacuates the wastewater from the tank to the designated external collection point or disposal site.



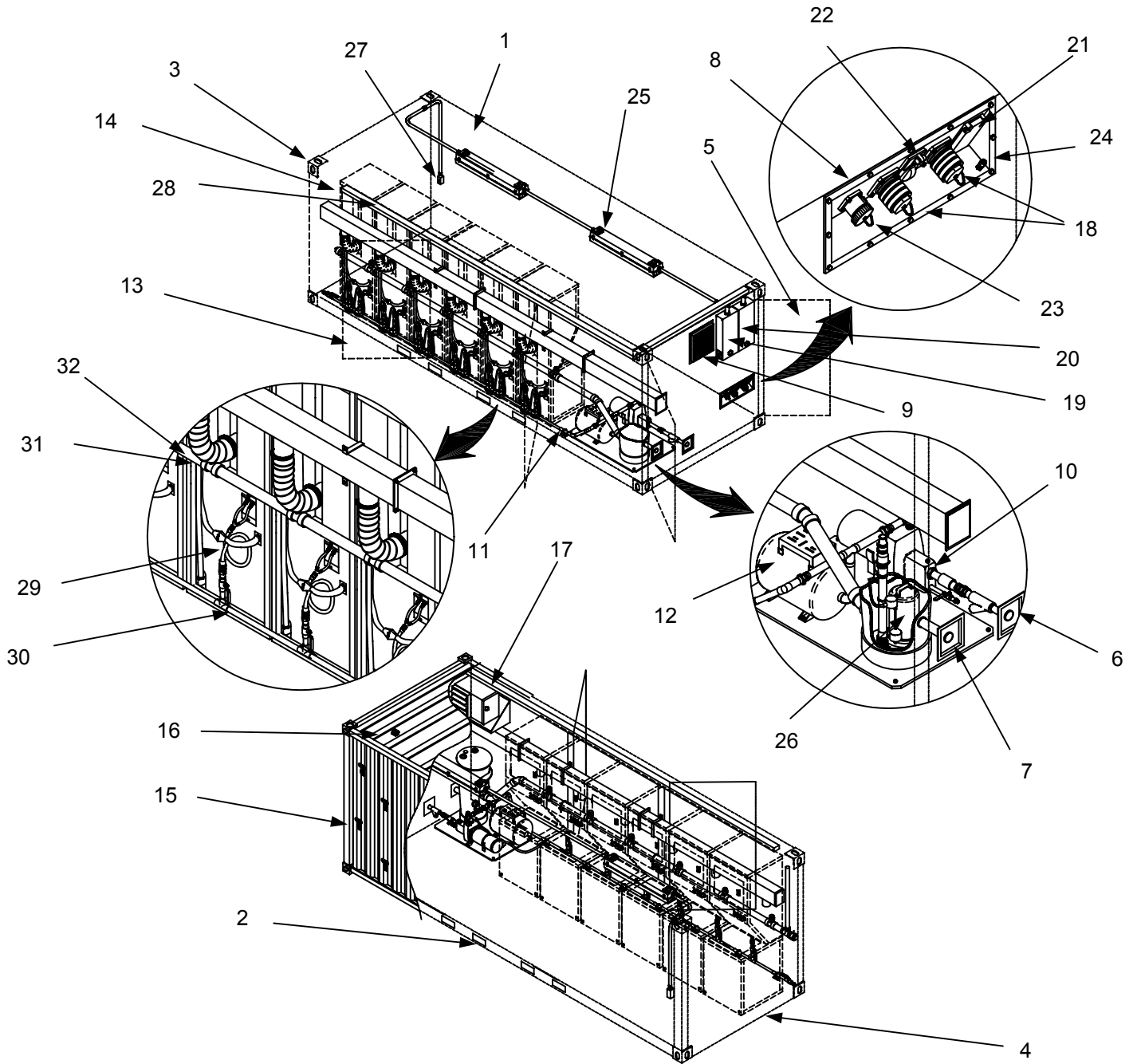

Location of Major Components (Internal).

**DESCRIPTION OF SYSTEM COMPONENTS.**

TEMPER Window Section, The TEMPER has an ISO Modified End Section mounted to the personnel double entry door. It is used as a workstation for folding laundry etc.  
 TM 10-8340-224-13 explains the use of the TEMPER.

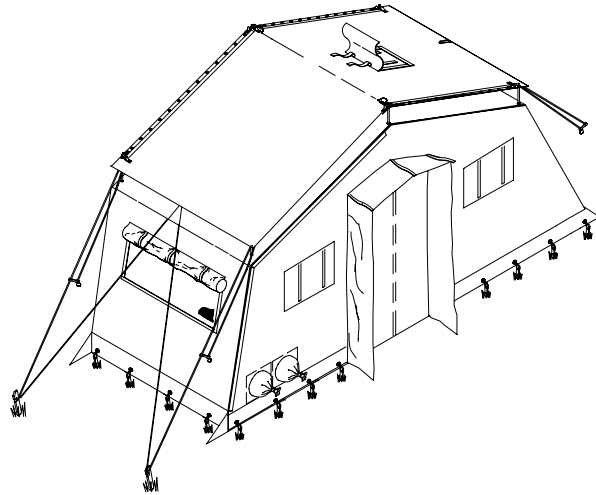

Power Cable, 100 AMP, 50 ft. The Power Cable is connected to the Pigtail and the connector J1 or J2 on the power entry box on the CSSL.  
 TM 9-6150-226-13 explains the use of the cable.

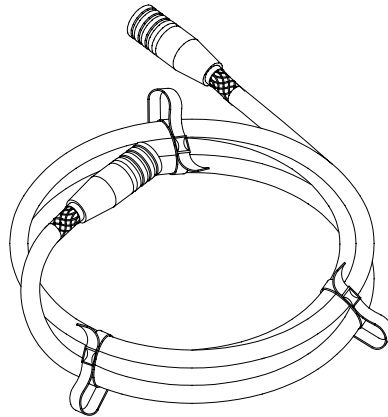

Hose Assembly, Fresh Water, The 2" diameter, 20' long freshwater hose supplies water from the source to the water entrance panel on the CSSL.

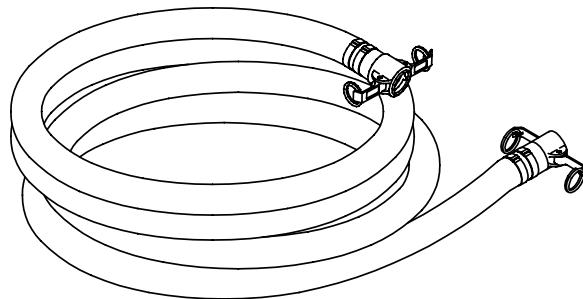

Grounding Rod. The grounding rod must be employed and connected to the container ground stud when ungrounded power is connected to the CSSL.

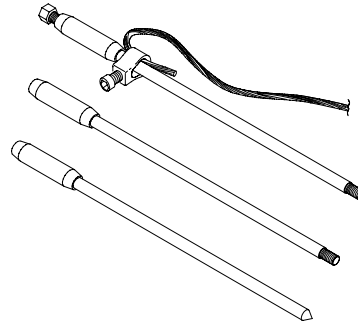

Hose Assembly, Discharge, Wastewater. The 2" diameter, 20' long wastewater hose is connected to the wastewater panel on the CSSL and the wastewater disposal site as required.

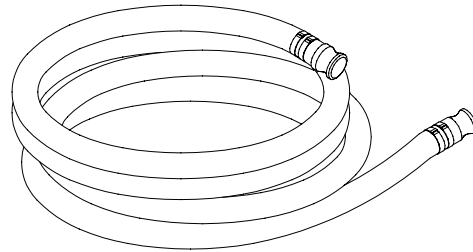

Fabric Tanks, 3,000 Gallon. Two each of these tanks are furnished with each CSSL. One for use as freshwater storage, the second as wastewater storage. These tanks are used if no municipal freshwater supply or sewage disposal is available. TM 10-5430-237-12&P explains the operation of the 3,000 gallon fabric tank.

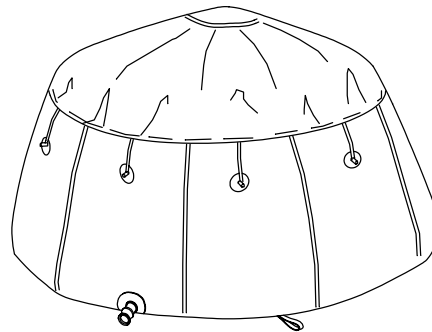

CSSL ISO Modified End Section. The Modified End Section connects the TEMPER to the CSSL. The Modified End Section is secured to the container using guy lines to the ISO corner fittings and cinch straps.

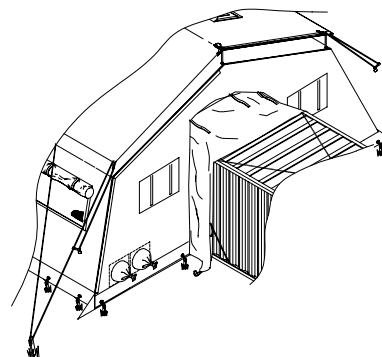

Pigtail. The Pigtail is used to connect the 100 AMP Power Cable to a non-commercial power source such as a generator. The exposed wire ends are attached to the generator, and the connector end mates to the 100 AMP power cable.

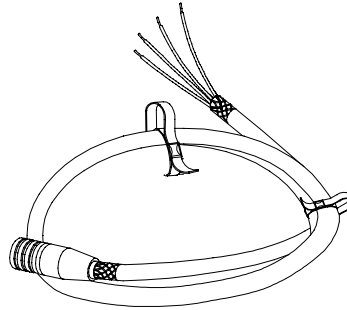

Lightset. The Fluorescent lightset is used for illumination inside the TEMPER. The CSSL provides power at the GFCI receptacle for the lightset.

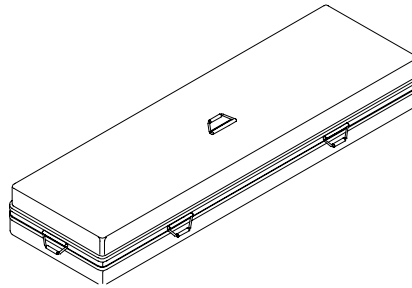

#### **COMMON TOOLS AND EQUIPMENT.**

For authorized common tools and equipment, refer to the Modified Table of Organization and Equipment (MTOE), CTA 50-970, Expendable/Durable Items (Except: Medical, Class V, Repair Parts, and Heraldic Items), or CTA 8-100, Army Medical Department Expendable/Durable Items, as applicable to your unit.

All Special Tools, TMDE, and Support Equipment for the CSSL are listed in WP 0067.

Repair parts are listed and illustrated in the repair parts and special tools list located in work packages 0043 through 0063.

**EQUIPMENT DATA.**

The following data pertains to the CSSL. Comparable data for the TEMPER, the freshwater pump, sump pump, and the commercial washer/dryers is contained in the appropriate equipment publications shown in WP 0002 00-7.

<b>External dimensions:</b>		
Length .....	19 feet, 10-1/2 inches .....	6.06 meters
Width .....	8 feet .....	2.44 meters
Height .....	8 feet .....	2.44 meters
<b>Internal dimensions:</b>		
Length .....	19 feet, 4 inches .....	5.80 meters
Width .....	7 feet, 6 inches .....	2.25 meters
Height .....	7 feet, 3-3/8 inches .....	2.18 meters
<b>Storage capacity:</b> .....	1064.8 feet <sup>3</sup> .....	31.9 meters <sup>3</sup>
<b>Door dimensions:</b>		
Personnel entrance door (front)		
Height .....	6 feet, 11-5/8 inches .....	2.09 meters
Width .....	7 feet, 7 inches .....	2.28 meters
Double service door (side)		
Height .....	6 feet, 11-5/8 inches .....	214 centimeters
Width .....	7 feet, 7 inches 96.5 .....	centimeters
Double service door (rear)		
Height .....	6 feet, 11-5/8 inches .....	2.09 meters
Width .....	7 feet, 7 inches .....	2.28 meters
<b>Weight:</b>		
Modified (CSSL), packed for movement ..	10,000 pounds .....	4536 kilograms
<b>Required electrical input:</b>		
CSSL .....	100 Amp, 208 VAC, 3 Phase	
Washers .....	20 Amp, 208 VAC, 3 Phase	
Dryers .....	100 Amp, 208 VAC, 3 Phase	
Sump pump .....	30 Amp, 208 VAC, 3 Phase	
Heater, space .....	50 Amp, 208 VAC, 3 Phase	
Fan, vent .....	20 Amp, 208 VAC, 3 Phase	
Lights, fluorescent .....	15 Amp, 110 VAC, single Phase	
Pump, freshwater .....	20 Amp, 208 VAC, 3 Phase	
External GFCI .....	20 Amp, 120 VAC, 3 Phase	
Power output .....	20 Amp, 208 VAC, 3 Phase	
<b>Pressure Tank Setting:</b>		
Low .....		15 PSI
High .....		30 PSI
<b>Required fresh water flow rate:</b> .....	30 gallons/minute .....	114 liters/minute
<b>Environmental:</b>		
Operating temperature range .....	32 <sup>0</sup> to 120 <sup>0</sup> Fahrenheit .....	0 <sup>0</sup> to 49 <sup>0</sup> centigrade
Maximum operating elevation .....	7000 feet .....	2128 meters

**REFERENCES.**

The following list contains publications necessary or helpful to support CSSL operation. These references are also listed in Work Package 0041 00.

Item/Function	Technical Manual Title	TM Number
Tank, 3,000 gallon (optional fresh water supply)	Operator's and Unit Maintenance Manual (Including RPSTL) Tank, Fabric, Self Supporting, 3,000 Gallon Water	TM 10-5430-237-12&P
TEMPER Window Section with ISO Modified End Section	Operator, Unit, and Direct Support Maintenance Manual for Tent, Extendable, Modular, Personnel (TEMPER)	TM 10-8340-224-13
100 AMP, 50 ft Power Supply Cable	Operator's, Unit and Direct Support Maintenance Manual for Distribution Illumination Systems, Electrical (DISE), and Power Distribution Illumination Systems, Electrical (PDISE) consisting of Electrical Feeder System M200, M200 A/P, M100, M100 A/P, M40, M40 A/P, M60, M60 A/P and Electrical Utility Assembly M46.	TM 9-6150-226-13
General Cargo Container	Unit and Direct Support Maintenance Manual (Including Repair Parts and Special Tools List), General Cargo Container	TM 55-8115-204-23&P

**END OF WORK PACKAGE**

---

**CONTAINERIZED SELF SERVICE LAUNDRY (CSSL)  
NSN 3510-01-485-0457  
THEORY OF OPERATION**

---

**General.** The CSSL system is designed for operation in temperate zones above 32<sup>0</sup> F. It can be operated on a continuous basis in 20 Hour cycles, provided adequate freshwater supply and wastewater discharge can be sustained on this basis. Minimum employment requirements for the CSSL are summarized in Work Package 0003 00-5.

**CSSL AND TEMPER.** The CSSL is housed in a general cargo container (1) modified to accommodate the electrically operated, cold-water service laundry facility. An 8 ft TEMPER Section (without vestibules) (2), is attached to the container (1) using a modified end wall (3), that connects to the TEMPER with hook and pile fasteners, and to the CSSL with a cinch strap at the end of the boot (4). Lines (5) attached to far corner fittings (6) and straps (7) attached through near corner fittings (8) secure the boot to the container. The double side doors (9) allow access to the rear of the washers and dryers (10).

**Power Distribution System.** The CSSL operates on 100 Amp, AC power. A power source, either commercial or appropriate generator (minimum 30kW), must be connected to the external power entry panel (11) connectors J1 and J2. Two power distribution panels (12) supply power through the internal GFCI circuit and to external components through the external GFCI (J3) and 60 AMP (J4) connector on the power entry panel (11).

**Washing System.** The stacked commercial washer/dryer units, (Maytag Model LSE7806ACE) (10) are mounted to the CSSL floor and inside wall for stability during operation and shipment. Washing is accomplished using cold water only.

**Freshwater.** A freshwater source (either municipal or a 3,000 gallon storage tank) is connected to the freshwater input panel (13) using a 2" diameter water hose (14). A minimum water pressure of 16 PSI is required to operate the washers. A pre-pressurized diaphragm-type tank (15) regulates the freshwater system pressure, turning on the 30 GPM freshwater pump (16) when the pressure reaches 20 PSI, and off at 40 PSI. When municipal water of sufficient pressure is supplied to the CSSL, the 30 GPM freshwater pump is not used. Distribution of freshwater to the washers is through a 3/4" diameter copper line (17). Each individual washer line is controlled with a ball valve (18). The freshwater system is protected during long-term storage with non-toxic anti-freeze. This anti-freeze is evacuated during the set-up procedures prior to using the system.

**Wastewater.** Wastewater generated by the washers (10) is drained through a 3" diameter PVC Pipe (19) into the wastewater tank (20) located in the rear of the container. When the tank contents reach a pre-set level, a float switch (21) activates a sump pump (22), that evacuates the contents through the wastewater panel (23) and a 2" diameter hose (24) into a 3,000 Gallon storage tank or directly into a wastewater disposal system.

**Drying System.** Dryers (10) are stacked on top of the washers and fastened to the CSSL using a metal frame bolted to the sidewall of the container. The dryer flexible exhausts (25) are connected to a metal exhaust duct (26) that exits through the utility wall.

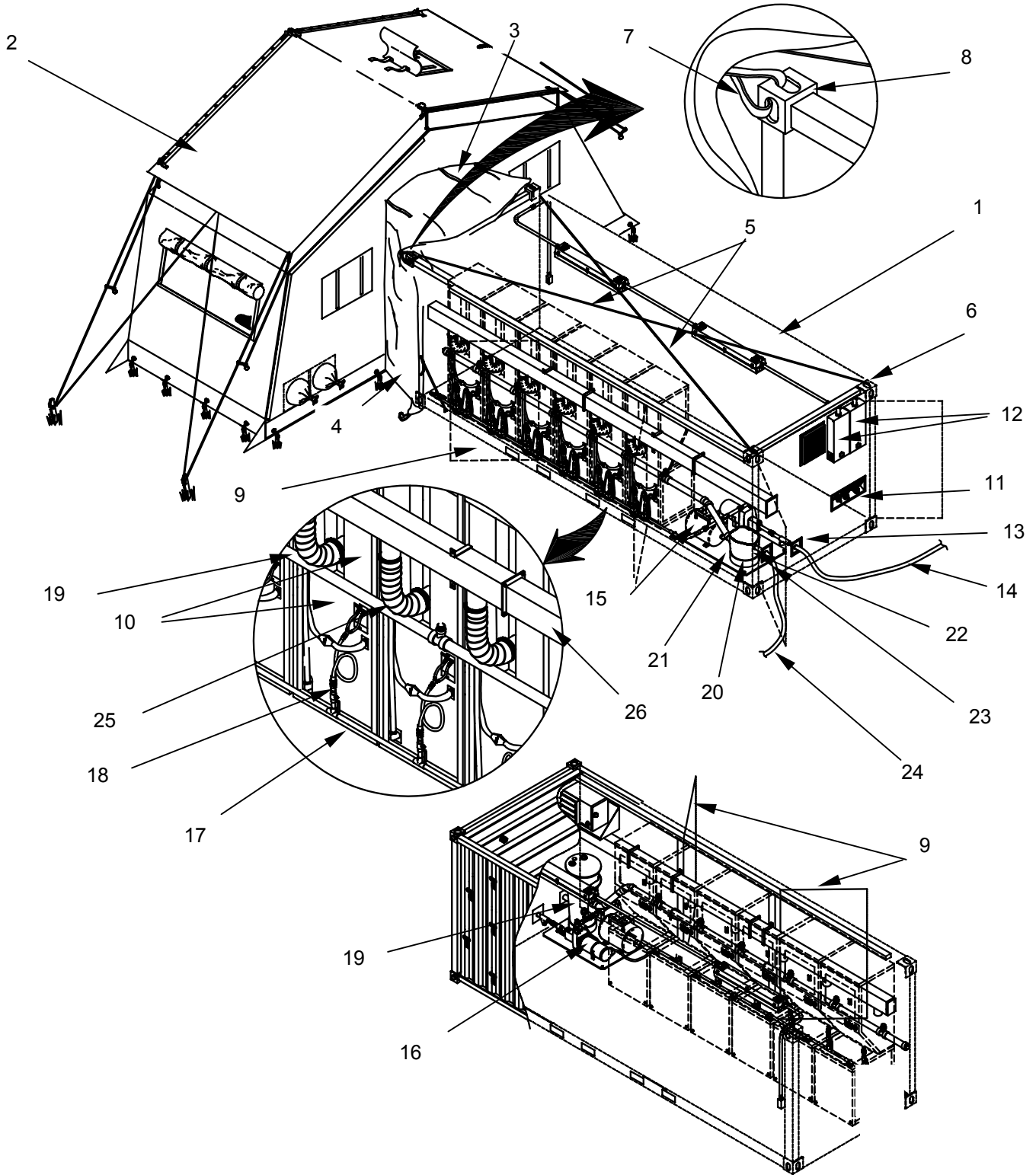

CSSL and TEMPER.



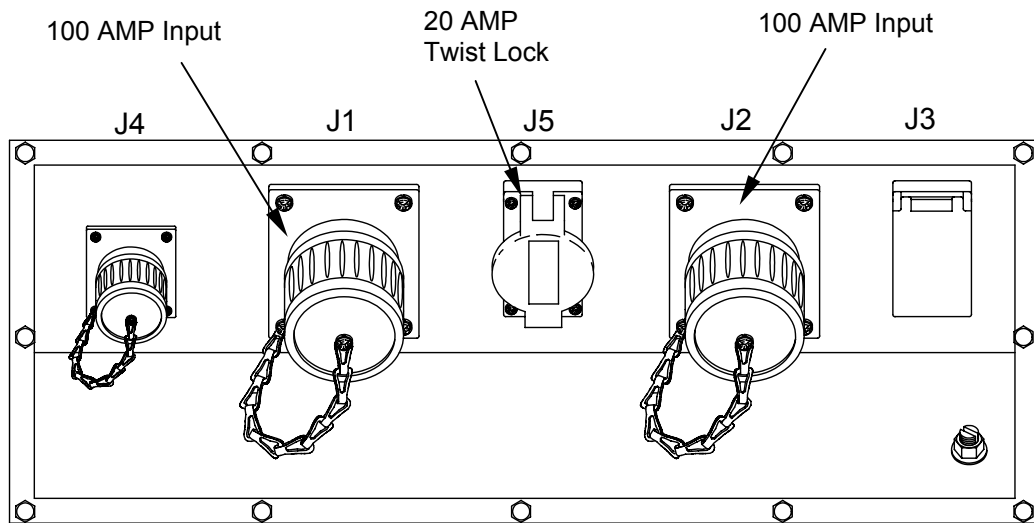
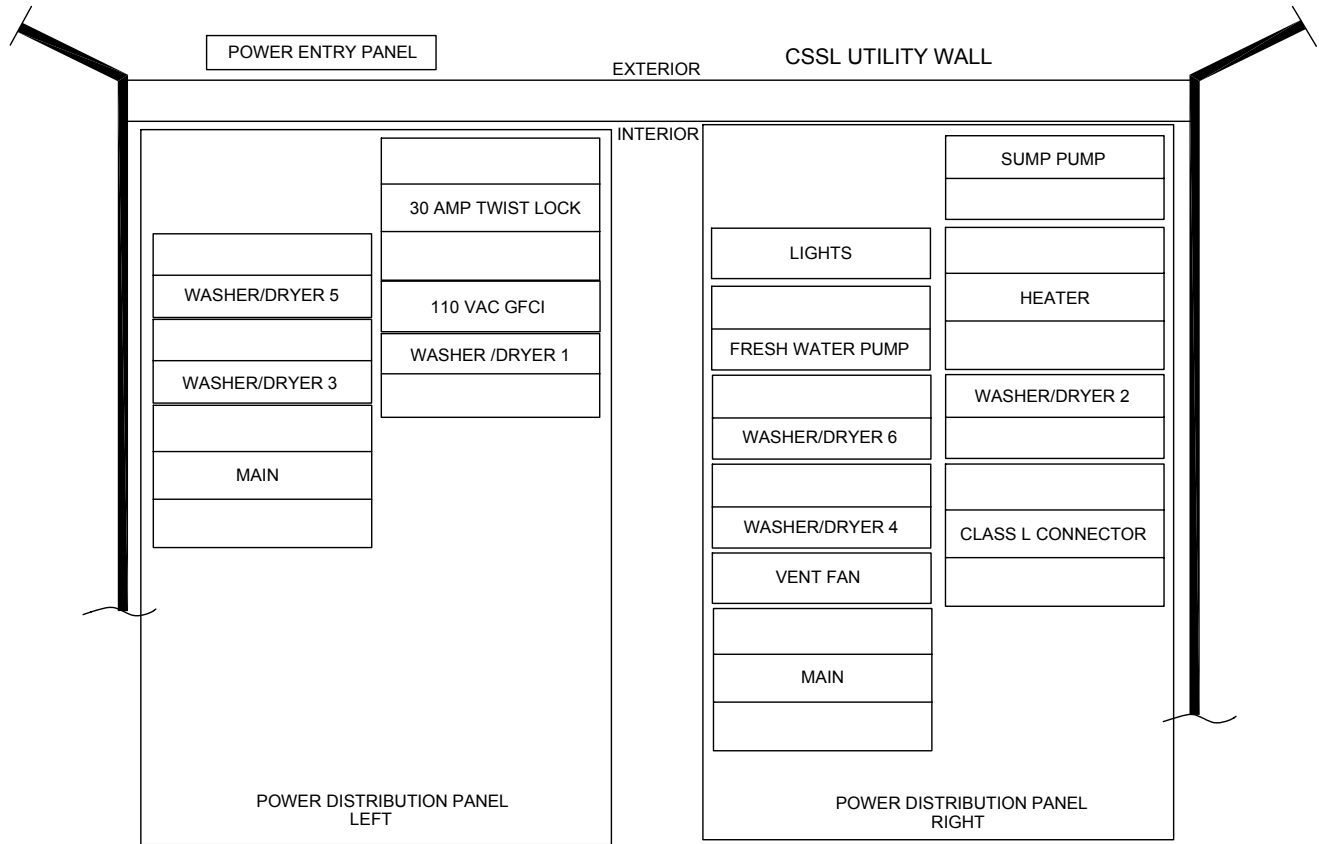

POWER ENTRY PANEL EXTERIOR VIEW

**Power Distribution System Schematic.**

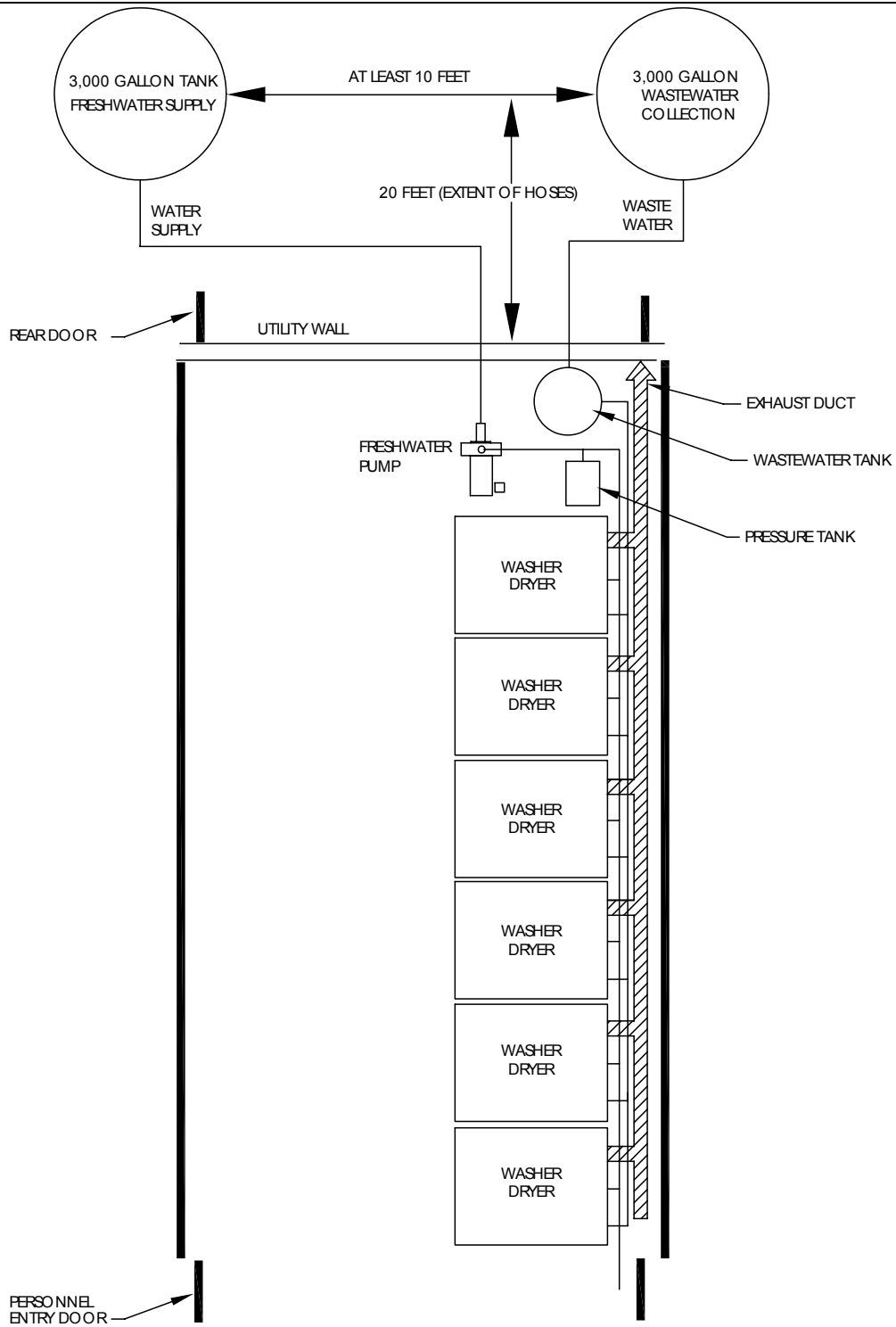

Washing and Drying System Schematic.

**CSSL MINIMUM EMPLOYMENT CONDITIONS.**

Following is a summary of the conditions and parameters required to employ a CSSL.

**Material Handling Equipment.** A 10,000 lbs lifting and moving device (i.e., forklift, etc.) is required to unload and position the packed CSSL container.

**Area Characteristics and Dimensions.** A level area of approximately 2,000 square feet is required. The ground must be free of obstacles and vegetation (trees, brush, etc.) so that the container sits firmly on the ground. If the 3,000 gallon freshwater or wastewater tanks are used, vehicular access is required. The employment area elevation should not exceed 7,000 ft (2128 Meters)

**Power Requirements.** The CSSL requires 100 AMP, 208 VAC, 3 Phase power. This can be provided through a commercial hookup, or through use of a generator (30 KW minimum). Only a qualified civilian or military (MOS 51R, 52C, 52D, or 52G) personnel must make the power connection.

**Utility Requirements.** A freshwater source supplying a maximum 8,700 gallons per 20-hour period (Consumption at full use) is required. The source should be either a municipal water system or another approved freshwater water source.

**Wastewater Disposal.** A wastewater disposal site must be available in the form of a municipal sewage system, or other approved site where the wastewater collected in the 3,000 Gallon wastewater tank can be evacuated.

**Water Service.** If 3,000 Gallon tanks are used for fresh and/or wastewater, water supply trucks (or service) and/or wastewater pumping tank trucks (or service) are required. Approximately three supply and collection round trips are required per day to keep the CSSL in full operation.

**END OF WORK PACKAGE**

THIS PAGE INTENTIONALLY LEFT BLANK

**TM 10-3510-224-13&P**

**CHAPTER 2  
OPERATOR INSTRUCTIONS  
FOR THE  
CONTAINERIZED SELF SERVICE LAUNDRY  
(CSSL)  
MODEL B**

THIS PAGE INTENTIONALLY LEFT BLANK

**CONTAINERIZED SELF SERVICE LAUNDRY (CSSL)  
NSN 3510-01-485-0457  
DESCRIPTION AND USE OF OPERATOR CONTROLS AND INDICATORS**

**CONTROLS AND INDICATORS.**

**General.** This work package contains information on the controls and indicators of the CSSL. For information concerning the controls and indicators of the stacked washer/dryers, consult the commercial literature furnished. For information on the controls and indicators of the 3,000 Gallon fresh water tank, freshwater pump, TEMPER, 100 AMP power supply pigtail and cable, or general cargo container, consult the appropriate publication (Refer to work package 0002 00 or 0041 00). The illustration below shows the location of the controls and indicators found on the CSSL. Subsequent illustrations and tables explain the specific function of each control and indicator.

Interior Light  
Switch

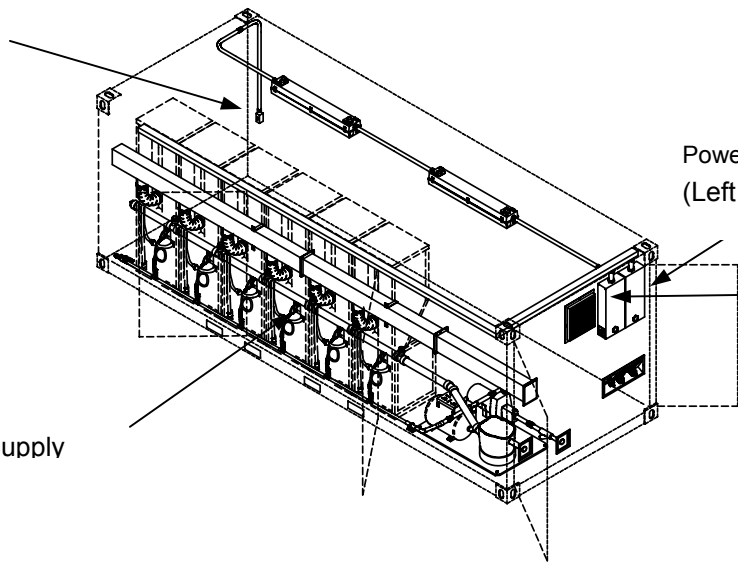

Power Distribution Panel  
(Left Side)

Power Distribution Panel  
(Right Side)

Freshwater Supply

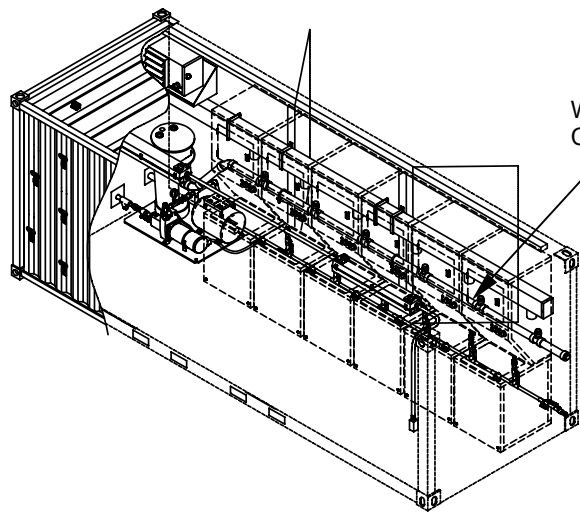

Washer/Dryer  
Controls

**Location of Controls and Indicators.**

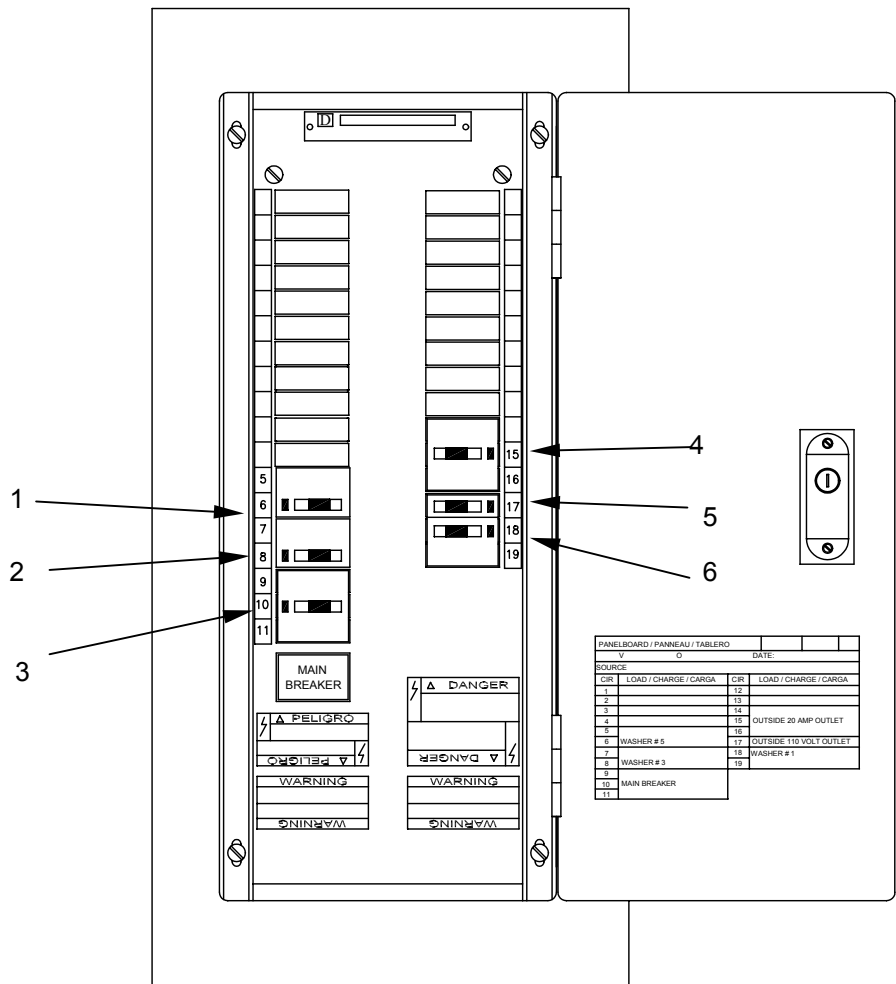

Power Distribution Panel (Left Side).

Table 1. Power Distribution Panel (Left Side) Controls and Indicators.

Key	Control and Indicator	Function
1	Position 6 Circuit Breaker, 30 AMP, 2 Pole	Controls operation of washer/dryer #5 circuit
2	Position 8 Circuit Breaker, 30 AMP, 2 Pole	Controls operation of washer/dryer #3 circuit
3	Position 10 Panel Board, 100 AMP, 3 Pole	Power Supply
4	Position 15 Circuit Breaker, 20 AMP, 3 Pole	Outside 20 AMP Twist-Lock Outlet
5	Position 17 Circuit Breaker, 20 AMP, 1 Pole	Outside 110 VAC GFCI Outlet
6	Position 18 Circuit Breaker, 30 AMP 2 Pole	Controls operation of washer/dryer #1 circuit



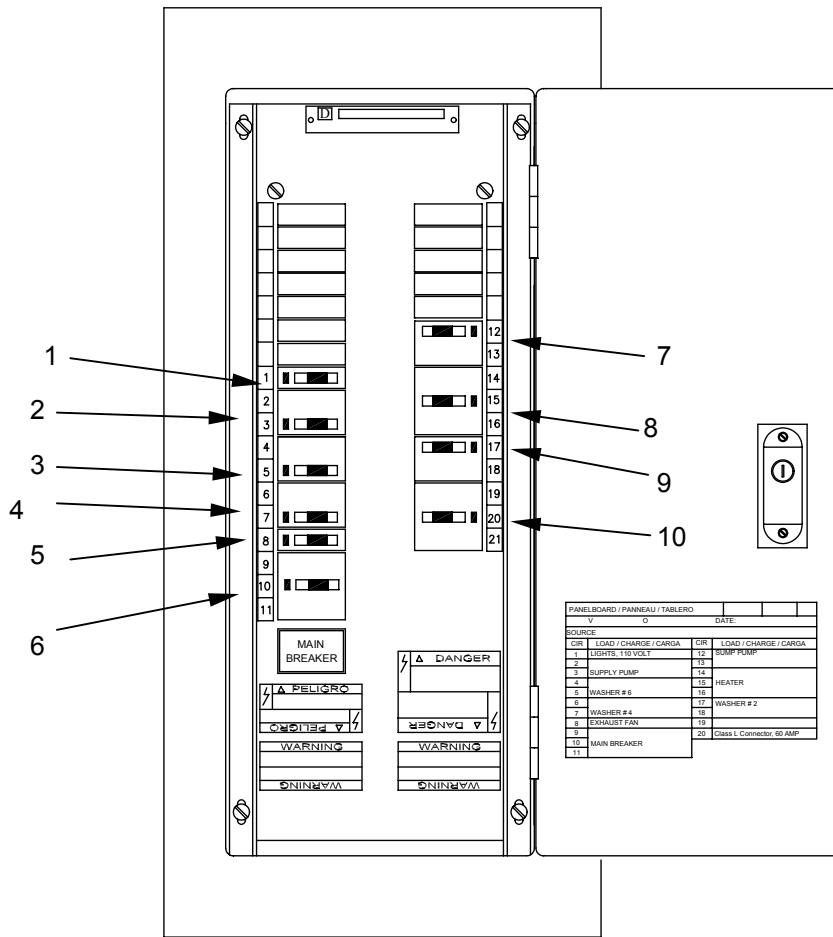

Power Distribution Panel (Right Side).

Table 2. Power Distribution (Right Side) Controls and Indicators.

Key	Control and Indicator	Function
1	Position 1 Circuit Breaker, 20 AMP, 1 Pole	Controls operation of interior light circuit
2	Position 3 Circuit Breaker, 20 AMP, 2 Pole	Controls operation of freshwater pump
3	Position 5 Circuit Breaker, 30 AMP, 2 Pole	Controls operation of washer/dryer #6 circuit
4	Position 7 Circuit Breaker, 30 AMP, 2 Pole	Controls operation of washer/dryer #4 circuit
5	Position 8 Circuit Breaker, 20 AMP, 1 Pole	Controls operation of vent fan circuit
6	Position 10 Panel Board 100 AMP 3 Pole	Power Supply
7	Position 12 Circuit Breaker, 20 AMP, 2 Pole	Controls operation of sump pump
8	Position 15 Circuit Breaker, 30 AMP, 3 Pole	Controls operation of heater
9	Position 17 Circuit Breaker, 30 AMP, 2 Pole	Controls operation of washer/dryer #2 circuit
10	Position 20 Circuit Breaker, 60 AMP, 3 Pole	Outside Class L Connector

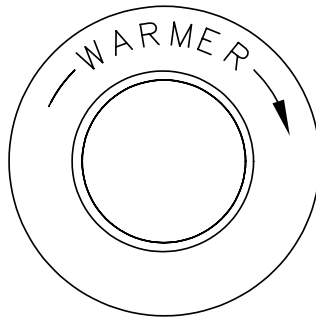
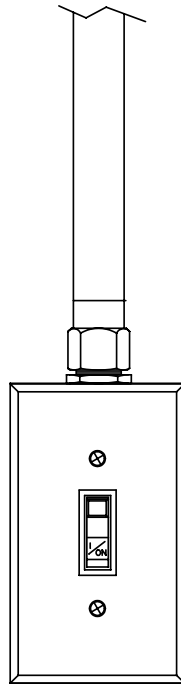

**Interior Lights and Space Heater Controls.**

**Table 3. Interior Lights and Space Heater Controls.**

Key	Item	Function
1	Light Switch	Controls operation of the interior lights
2	Heater Control	Controls operation of the heater

**LABELS AND INSTRUCTION PLATES.**

**General.** The following labels and instruction plates are found on the CSSL. For information concerning labels and instruction plates for component items such as the washer/dryers, 3,000 Gallon wastewater collection tank, 3,000 gallon freshwater tank, freshwater pump, TEMPER, or the 100AMP power supply pigtail and cable, consult the appropriate publication (Refer to work package 0002 or 0041 00).

**Modified General Cargo Container Door.**

Labels. A data plate, located on the container, reflects the following information:

CONTAINER, CARGO	
CONTAINERIZED SELF-SERVICE LAUNDRY (CSSL)	
MFD BY: 81337	NSN: 3510-01-485-0457
SPECIFICATION: 5-13-6536	TARE WEIGHT: 5510 LBS
CONTROL NUMBER:	DATE: DEC. 25,2001
CONTRACT NUMBER	
TECHNICAL MANUAL: TM 10-3510-224-13&P	

**Power Distribution Panels.**

**Labels.** On the inside of each power distribution panel are main breaker identifying labels (1), warning labels (2) and danger labels (3) as well as a panel load identification list (4).

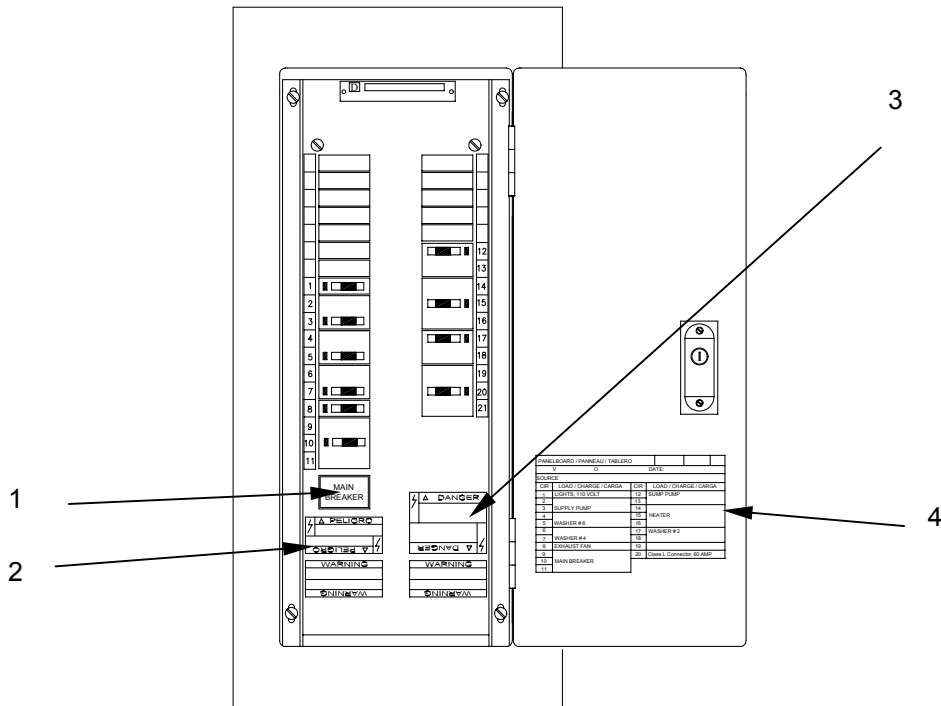

**Space Heater.**

**Label.** The space heater control located on the unit is labeled as shown below.

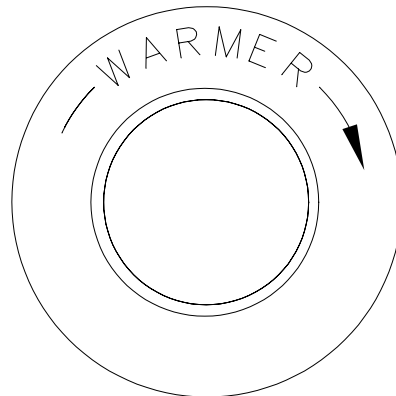

**Washer and Dryer.**

**Label.** Washer and Dryer operating instruction are posted on each dryer door.

## WASHER OPERATING INSTRUCTIONS

**NO TA-50****NO TENNIS SHOES**

1. OPEN LID, ADD DETERGENT THEN CLOTHES, CLOSE LID.
2. (USE RECOMMENDED AMOUNT OF DETERGENT FOR A SMALL TO MEDIUM LOAD. THESE MACHINES ARE SMALLER CAPACITY THAN MOST WASHERS AND REQUIRE LESS DETERGENT)
3. SELECT WASH CYCLE RECOMMENDED ON GARMENT. (REGULAR, PERMANENT PRESS OR KNITS / DELICATES)
4. SELECT LOAD SIZE. (SMALL, MEDIUM, LARGE)
5. SELECT WARM WATER TEMPERATURE. (THERE IS NO HOT WATER BUT A WARM FILL WILL FILL THE WASHER FASTER)
6. START WASHER. (PULL OUT CONTROL KNOB) THE WASHER WILL FILL AND RUN UNTIL THE LOAD IS COMPLETE.
7. DO NOT OPEN LID DURING THE WASH CYCLE. IF LID IS LIFTED THE WASHER WILL STOP. IF THIS OCCURS, CLOSE THE LID AND THE WASHER WILL START AGAIN.
8. IF A LOAD IMBALANCE OCCURS THE WASHER WILL STOP. PUSH IN THE CONTROL KNOB. OPEN THE WASHER AND REDISTRIBUTE THE CLOTHES, CLOSE THE LID AND PULL OUT THE CONTROL KNOB. THE WASH CYCLE WILL RESUME FROM WHERE IT STOPPED.

## DRYER OPERATING INSTRUCTIONS

1. CLEAN LINT FILTER BEFORE EACH USE. (Dispose of lint in trashcan)
2. PLACE CLOTHES IN DRYER.
3. SELECT TYPE OF DRYING CYCLE PREFERRED.
4. SELECT TEMPERATURE (REGULAR, DELICATE) RECOMMENDED ON THE GARMENT LABEL.
5. PRESS START. (THE DRYER WILL AUTOMATICALLY STOP WHEN THE CYCLE SELECTED IS COMPLETE.

**GFCI Receptacles.**

**Label.** The GFCI Receptacle located on the power entry panel is labeled as shown below.

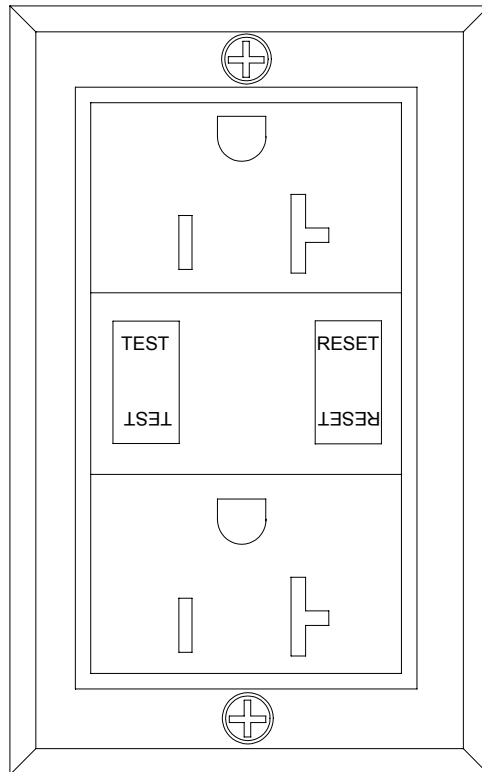

**END OF WORK PACKAGE**

---

**CONTAINERIZED SELF SERVICE LAUNDRY (CSSL)  
NSN 3510-01-485-0457  
OPERATION UNDER USUAL CONDITIONS**

---

**OPERATION UNDER USUAL CONDITIONS.****Siting Requirements.**

---

**WARNING**

---

The CSSL container weighs approximately 10,000 pounds when packed. Lift and move the container only with material handling equipment of at least 10,000 lbs capacity. Observe all safety precautions. Never stand under a CSSL container when it is being lifted. Unpacking components requires at least four persons.

This section outlines the siting requirements of the CSSL, and describes the assembly of its components. It also provides procedures for the preparation, and operation of the CSSL under usual conditions. Refer to work package 0006 00 for Operation Under Unusual Conditions. Refer to work package 0003 00 for the summary of CSSL Minimum Employment Conditions.

Unloading and moving the CSSL requires a forklift of at least 10,000 lbs capacity. Use the built-in, outside forklift pockets on the container to move the CSSL.

For storage, CSSL containers may be stacked six-high, as long as the bottom unit is positioned on a firm, level surface. Hoisting requires 10,000 lbs minimum capacity hoists and slings connected to the corner ISO fittings.

Read all warnings and cautions within this section and follow procedures outlined herein to ensure safe operation of the CSSL and associated equipment.

**Site Selection.**

The selected site should be large enough to accommodate the CSSL container with attached TEMPER (without vestibules). It should be within reasonable proximity to a freshwater source and wastewater disposal facility. If 3,000 Gallon fabric tanks furnished with each CSSL are to be used for freshwater storage and wastewater collection, sufficient space is needed to position the tanks as specified in work package 0003 00. The selected site should be free of large holes, trees, rocks, and debris and be within 5 degrees of level. There should be sufficient drainage to prevent rainwater accumulation.

Proximity to a power source is also required. In addition, the power supply cables, the water supply, and wastewater drain hoses should not be subjected to vehicular traffic and out of the way of facility users.

Vehicular access to the 3,000 Gallon tanks (if used) is required to frequently replenish freshwater and drain the wastewater. Additional space is required to position a 30 kW (minimum) generator (if used) to supply power to the CSSL and consideration for its refueling. Ideally, the container should be located within the distance of the furnished utility cables and hoses as follows:

100 AMP Cable	50 ft
Freshwater Supply Hose	20 ft
Wastewater Drain Hose	20 ft

**UNPACKING AND INVENTORY OF CSSL COMPONENTS.**

With a 10,000 lbs capacity forklift, using the outer container forklift pockets (1), position the CSSL (2) in its designated area.

**CAUTION**

The CSSL container must be within 5 degrees of level for proper operation and prevention of damage to the washer/dryers.

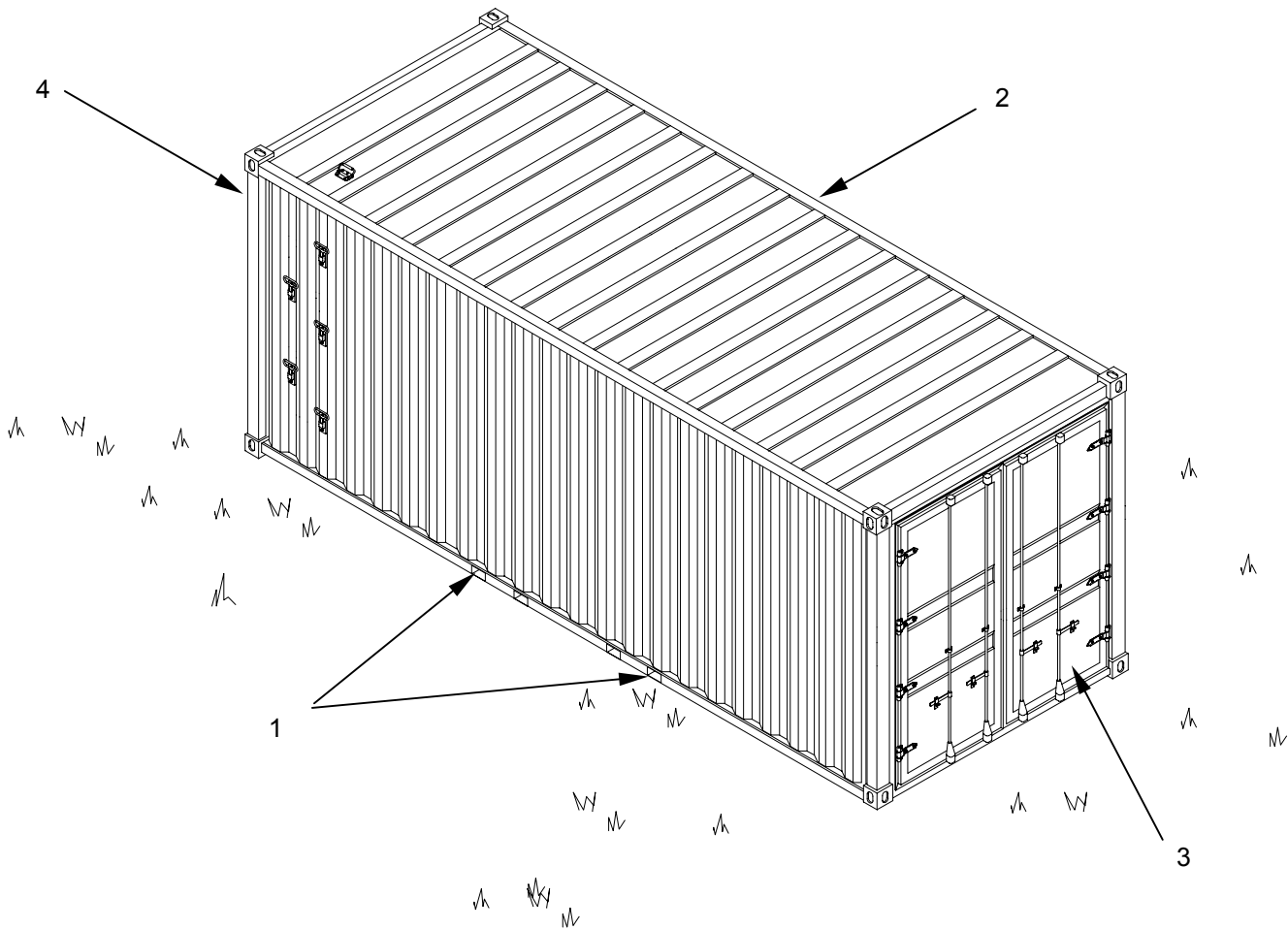

Open the personnel entry doors marked OPEN FIRST (3). Open the opposite doors marked REAR DOOR (4). Loosen and remove tie-down straps secured to the provisions on the floor. Place straps into the footlocker after setup is complete.



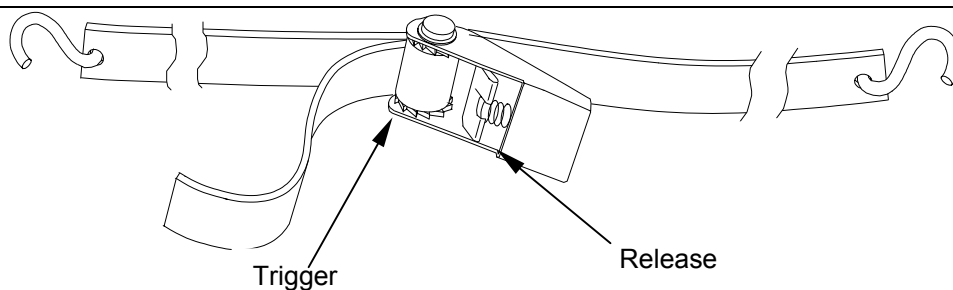

Squeeze the trigger with first two fingers, lift the release with the thumb. Slide the strap through the spool.



### **WARNING**

At least four persons are required to unpack the CSSL. To avoid injuries, observe the lift requirements shown in the table below.

Unpack the CSSL in the order shown in the following table. Identify and inventory items being removed using the table below and the packing plan on the following page. Position the unpacked items outside the container as shown in the illustration on page 0005 00-5.

Check condition of components during unpacking and report any discrepancy to your supervisor.

Table 1. CSSL Contents.

Nomenclature	Quantity	Condition	Lift Requirements
Footlocker, containing:	1		1 Person
Garden Hose	1	Drained, coiled, ends connected	
Technical Manual	1	In plastic bag	
120 VAC Power Cord	1	Cleaned and coiled	
Adjustable Wrench	1	Cleaned	
Flash Light	1	Cleaned and Operating	
Washer/Dryer Repair Parts	6	Original Packs	
Tape	1	Duct tape	
Screwdriver, Close Quarter	1	Cleaned	
Freshwater Supply Hose 2", 20'	1	Drained and coiled	1 Person
TEMPER 8 ft window section	1	Cleaned and folded	4 Persons
Grounding Rod	1	Cleaned, with wire attached	1 Person
Fluorescent Light Set	1	In Case	1 Person
Freshwater Tank, 3,000 Gallon	1	Drained clean and folded	4 Persons
Table, Folding	4	Folded and tied	1 Person each table
Pigtail	1	Cleaned and Coiled	1 Person each pigtail
100 AMP Cable, 50 ft	2	Cleaned, coiled, caps installed	2 Persons each Cable
TEMPER Frame Components	1	Cleaned and folded	4 Persons
Wastewater Drain Hose 2"	1	Drained and coiled	1 Person
ISO Modified End Section	1	Cleaned and Folded	2 Persons
Pigtail	1	Cleaned and Coiled	1 Person
TEMPER End Section	1	Cleaned and Folded	4 Persons
Wastewater Tank 3,000 Gallon	1	Drained clean and folded	4 Persons
Tie Down Straps	5	Remove as Unpack Progresses	1 Person

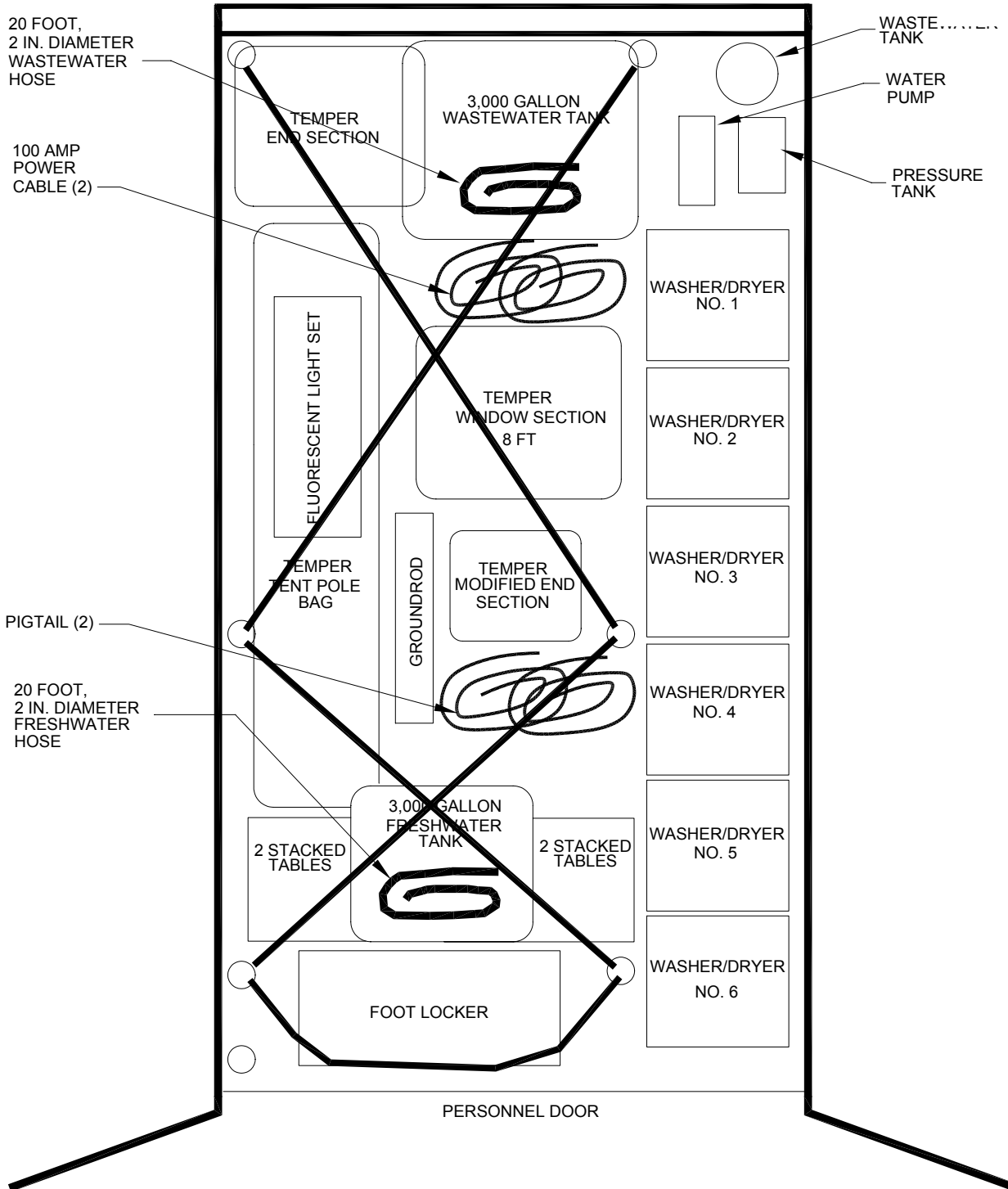

CSSL Packing Diagram.

Freshwater  
Hose, 2"x 20 ft.

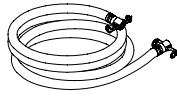

Wastewater  
Hose, 2"x 20 ft

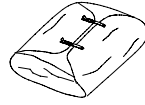
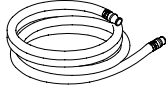

3,000  
Gallon  
Fabric  
Tanks

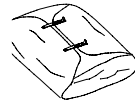

Grounding  
Rod  
Assembly



100  
AMP  
Power  
Cables



Pigtails

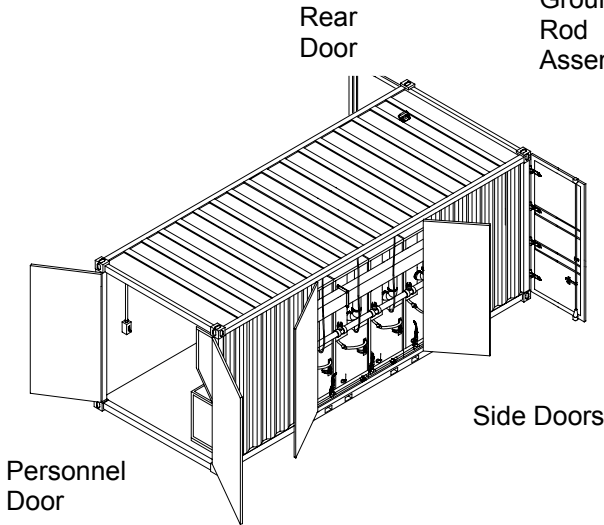

Personnel  
Door

Rear  
Door

Side Doors

Folding  
Tables (4)

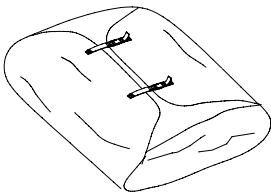
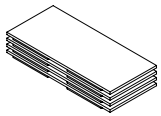

TEMPER Window Section, 8 ft

TEMPER End  
Section

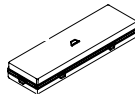
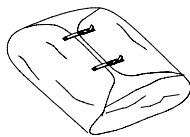

Lightset

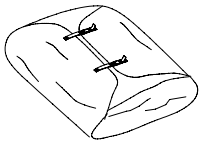

TEMPER  
ISO Modified  
End Section

Footlocker  
(For contents refer  
to Table 1)

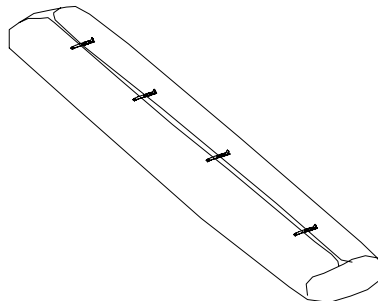
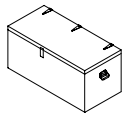

TEMPER Frame  
Components

**Prepare Power Distribution System for Use.****NOTE**

Only a qualified civilian (electrician), or qualified military personnel with MOS 51R, 52C, 52D, or 52G must perform this procedure.

**WARNING**

The general cargo container **MUST BE ELECTRICALLY GROUNDED**. Failure to ground the container may result in serious injury or death from electrical shock.

1. The container must be grounded as follows:
2. Drive grounding rod (1) 8 feet into the ground near the power entry panel (2).
3. Back off the hex nut (3) on grounding terminal (4) to expose the eye (5).
4. Insert the ground cable (6) through the eye and tighten hex nut (3).
5. Ensure cable (6) is securely attached to grounding rod (1). Tighten setscrew (7) as necessary.

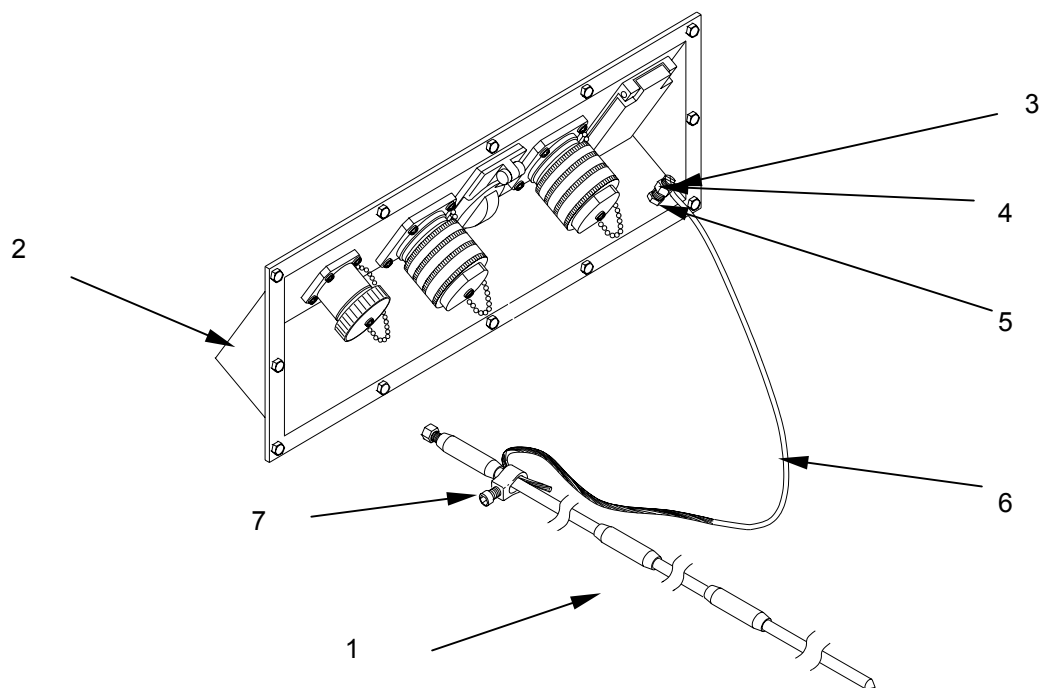

### CAUTION

Qualified civilian personnel (electrician) or military personnel in MOS 51R, 52C, 52D, or 52G are required to connect the 100 AMP power cables. Ensure all circuit breakers in both circuit breaker panels are set to OFF to prevent shorting of equipment when power is initially connected.

6. Connect 100 AMP, 50 ft cables (1) to power input plugs (2) and (3) on the power entry box (4).
7. Have qualified personnel, as noted above, connect pigtail connector end to 100 AMP, 50 ft cables (1) and then connect the pigtails to the power source.
8. If TEMPER interior lights are used, lay out and connect 120VAC extension cord (5) (in footlocker) to the TEMPER lights (6) and lay out towards the GFCI receptacle (7) on the power entry panel (4).
9. Switch main breakers in both power distribution panels to ON. Switch circuit breakers #1 on the right side panel, and circuit breaker #17 on left side panel (if needed) to ON. To operate the interior lights, turn the switch on the side wall to ON.

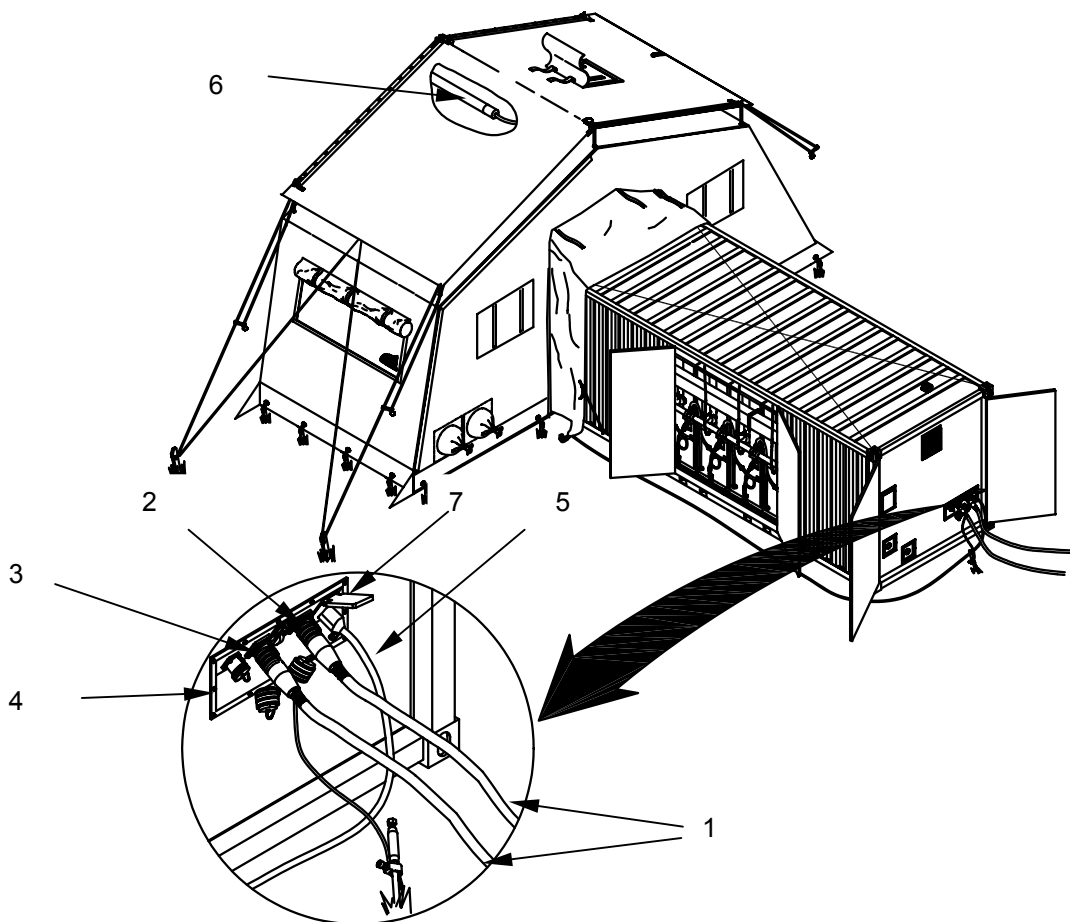

**Set up Water System External Components.**

Determine what external water systems components will be needed. This will depend on the availability of freshwater, and the method of wastewater disposal. If municipal facilities are not available, the CSSL can use water tank trucks for resupply and wastewater collection trucks for disposal to keep the CSSL in operation. Place the water system components to be used in position as shown on the following illustration, observing the distances indicated.

**WARNING**

If municipal fresh water is not available, employ the 3,000 Gallon collapsible fabric tank labeled FRESHWATER TANK, with subsequent refilling by tanker. Keep the tank and freshwater hoses away from wastewater hoses and any wastewater storage in the vicinity. Serious health problems may result from water contamination. Refer to TM 5-5430-237-12&P for instructions to set up and prepare the tank for operation.

1. Connect the 2 inch freshwater hose **(1)** to the freshwater entry panel **(2)** on the container utility wall.
2. Lay out the full length of the hose to the 3,000 Gallon collapsible fabric storage tank labeled DRINKING WATER ONLY **(3)**.
3. Fill the 3,000 Gallon collapsible fabric storage tank labeled DRINKING WATER ONLY **(3)** with freshwater.

**WARNING**

Ensure that wastewater is properly disposed of either through an approved municipal sewage system, or collected in the 3,000 Gallon collapsible fabric tank labeled WASTEWATER TANK, with subsequent evacuation by tanker. Keep wastewater hoses away from freshwater hoses and any freshwater supply in the vicinity. Serious health problems may result from water contamination. Refer to TM 5-5430-237-12&P for instructions to set up and prepare the tank for operation.

4. Connect the 2-inch wastewater hose **(4)** to the wastewater panel **(5)** on the container utility wall.
5. Lay out the full length of the hose to the 3,000 Gallon collapsible fabric storage tank labeled WASTEWATER TANK **(6)**, or a designated municipal disposal point **(7)**.

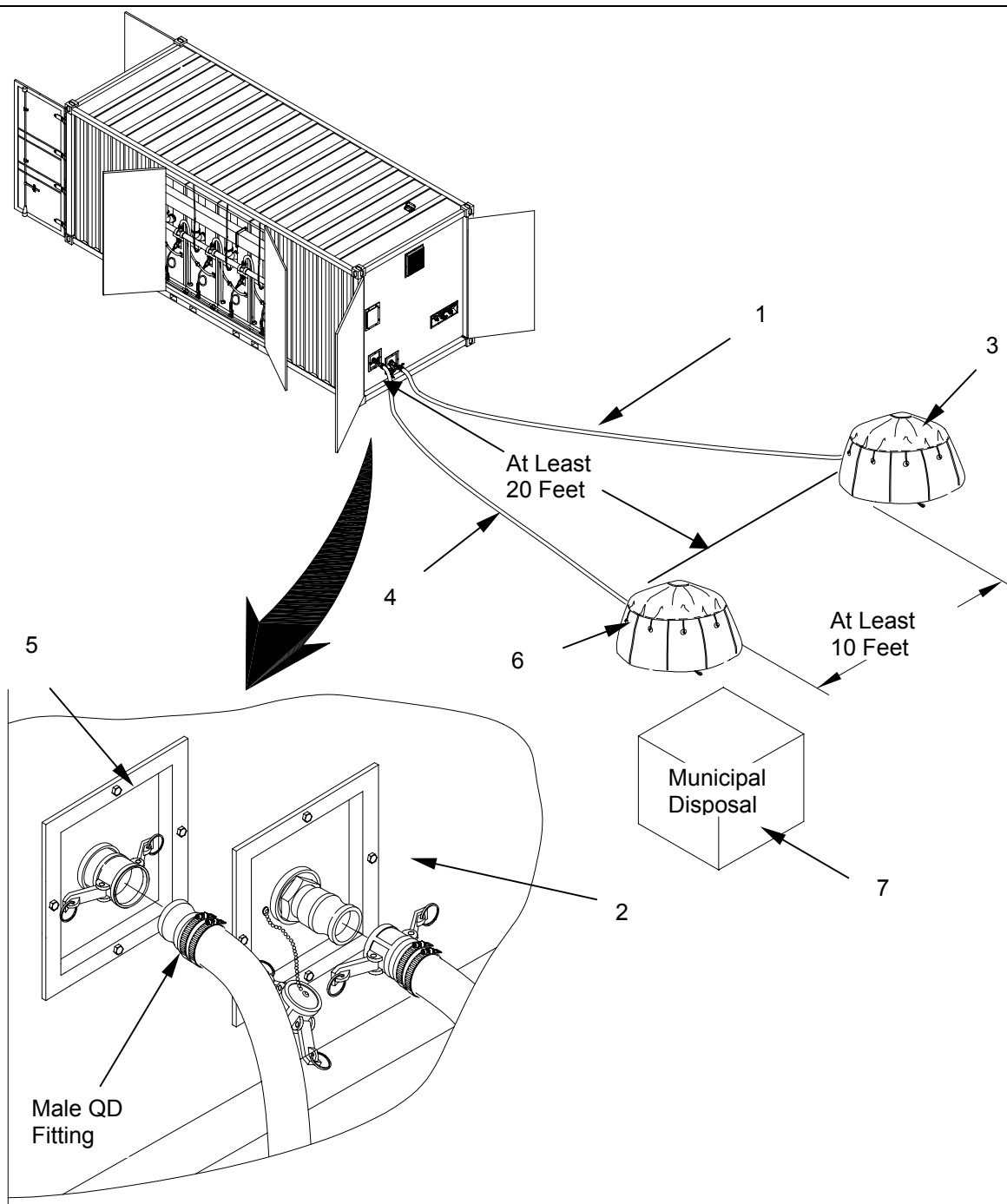



**PREPARE WASHERS AND WATER SYSTEM FOR USE.**

1. Open container side doors and check water hoses (1) for secure attachment to the Y connector (2), the washers (3) and the freshwater supply line (4). Hand-tighten hoses if necessary.
2. Ensure ball valves on washer water supply lines (5) are open (handle aligned with the water line).
3. Open the ball valve at the end of the supply line (Washer/Dryer nearest the personnel door) (6). Leave side doors open.
4. Open washer lids (7) and remove plastic shipping brackets (8). Place brackets on top of dryers and retain for use during return shipment.
5. Once the CSSL is functional, flush the freshwater lines by operating each washer for two complete cycles.

**Flush Freshwater Lines.****WARNING**

The Containerized Self Service Laundry is shipped with an anti-freeze solution pumped into the freshwater lines. The anti-freeze solution is non-toxic but is unsuitable for drinking or washing. **DO NOT OPERATE THE CSSL** until the freshwater lines have been flushed.

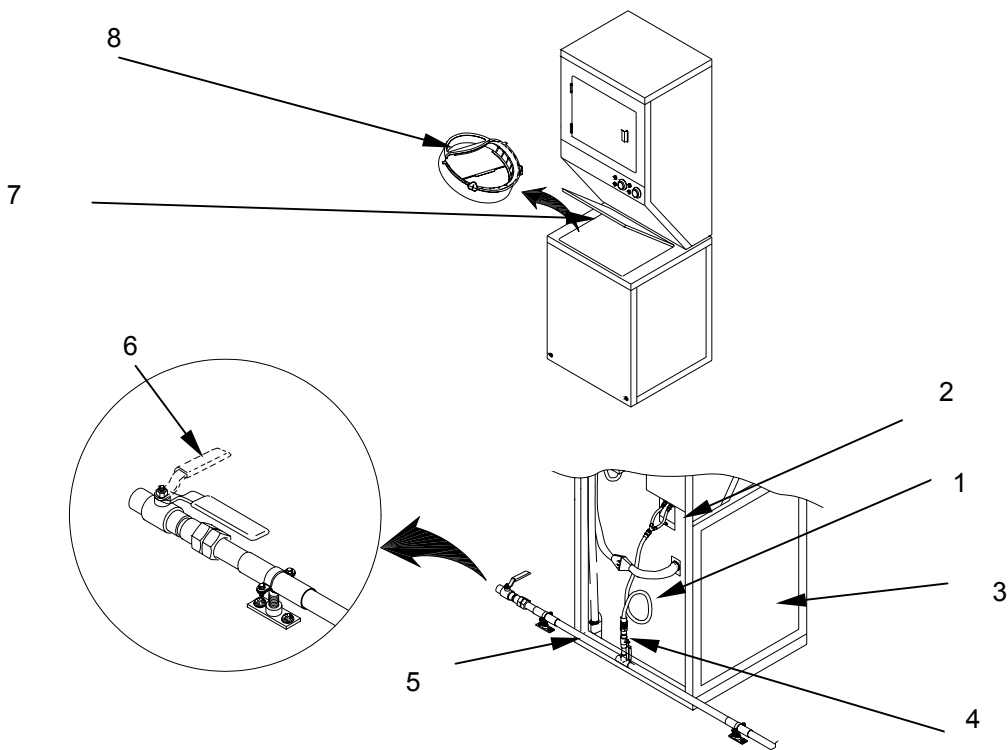

**PREPARE DRYERS AND DRYING SYSTEM FOR USE.**

1. Open doors on dryers (1) and ensure lint traps (2) are clean and in place.
2. Through container side doors, gain access to area behind dryers and ensure exhaust hoses (3) are connected to dryer outlets (4) and exhaust vents (5) in the main duct. Gain access to dryer number 6 from the personnel door.
3. If necessary, install exhaust hoses (3) using hose clamps to secure them to dryer outlets (4) and exhaust vents (5) in the main duct.

**CAUTION**

Do not operate dryers without exhaust hoses installed, or with ripped or torn hoses. This will damage the equipment and represent a fire hazard.

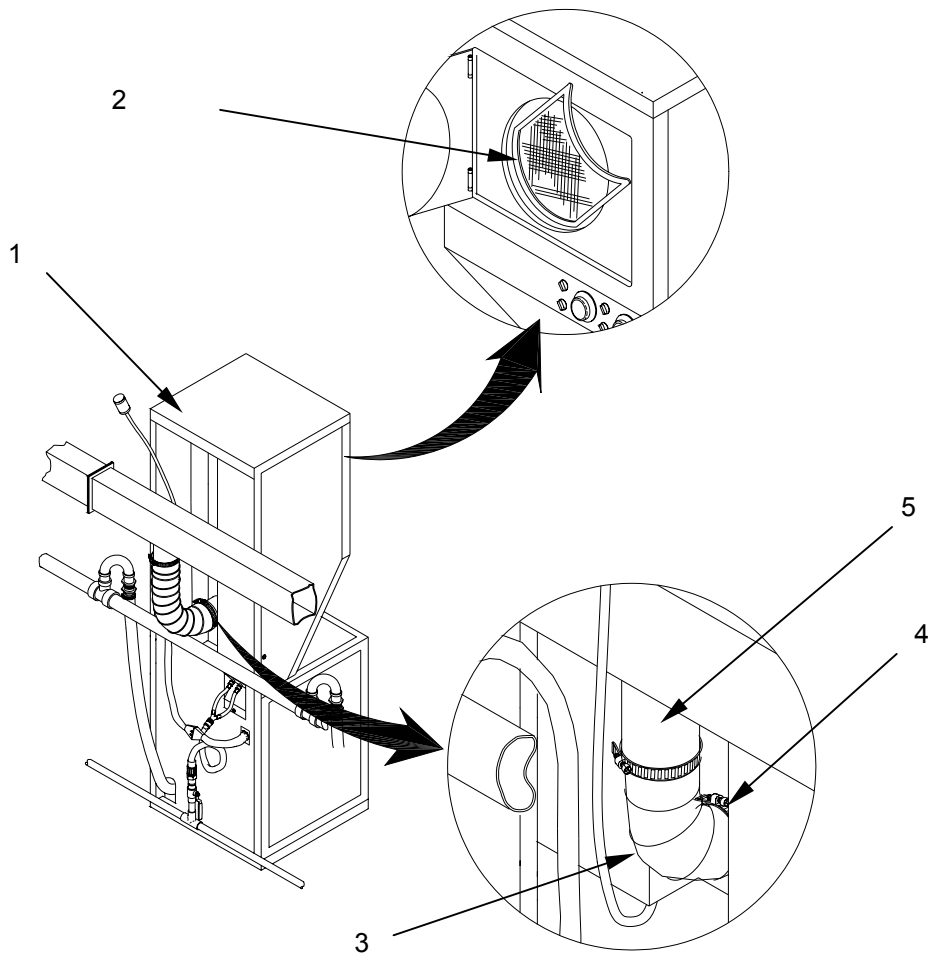

**PREPARE TEMPER WITH ISO MODIFIED END SECTION FOR USE.****WARNING**

The assembled TEMPER section is heavy. At least four persons are required to move the TEMPER section into position. To avoid injuries, ensure personnel are available before attempting to lift the tent. Personnel in the 5<sup>th</sup> percentile size group may require a step aid during this procedure.

The following procedures provide detailed instructions for erecting a TEMPER window section, end section, and ISO modified end section for use with the CSSL. For repair procedures or more detailed information on the TEMPER, refer to TM 10-8340-224-13.

1. Close the personnel double doors on the container.
2. Use WP 0002 to identify individual pieces of the TEMPER section. Pay particular attention to the difference between the modified TEMPER end section **(1)** and the regular TEMPER end section **(2)**.

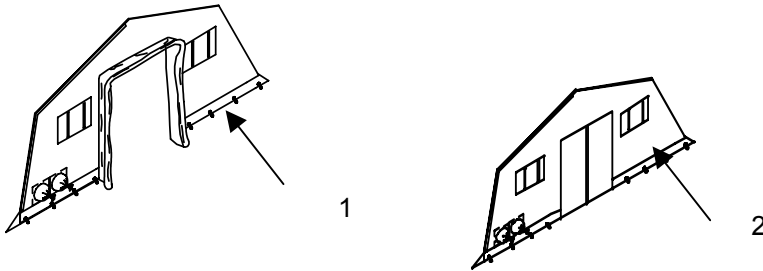

3. Assemble the TEMPER section with the ISO modified end section (1) facing towards the container personnel double doors.

**WARNING**

Frame assembly hinges can pinch or crush hands and fingers. Keep hands and fingers away from frame assembly ridges and eaves.

**CAUTION**

Do not twist or turn frame components when handling. Damage to equipment may result.

**NOTE**

The frame assemblies are erected in three stages: kneeling, partially-erect, and erect. These stages permit the attachment of components without the aid of ladders. Both rigid and sectionalized arch assemblies are in use in the field. After initial assembly, the sectionalized arch assembly does not vary in function from the rigid arch assembly. Erect tent from top to bottom, end section towards opposite end section.

**Arch Assembly.**

1. Remove roof arch assembly **(1)** and side arch assemblies **(4)** from frame sections cover assembly bundle.
2. Ensure all quick release pins **(2)** are disengaged.

**CAUTION**

Insert quick release pins towards inside of tent end assemblies. Tent fabric may tear if inserted towards outside.

3. Align the holes in roof arch assembly **(1)** with holes in the ridge gusset plate **(3)**. Then insert the quick release pin **(2)**.
4. Unfold the side arch assembly **(4)** away from roof arch assembly **(1)**.
5. Connect the roof arch assembly **(1)** to the side arch assemblies **(4)** to form arch assembly **(5)**.
6. Lay arch assembly **(5)** flat on the ground.

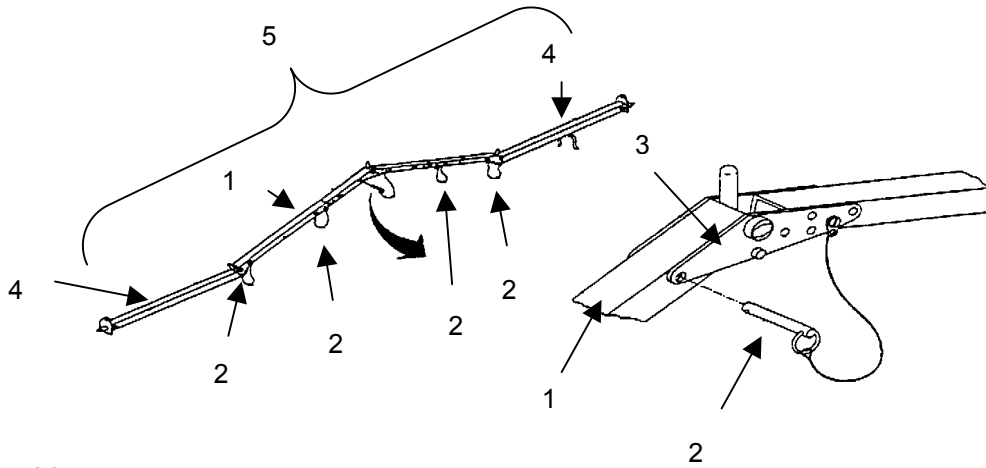

**Header Assembly.**

**NOTE**

The header assembly will be pinned to the arch assembly between the ridge and eave.

1. Identify the header assembly (1).
2. Slide the header assembly end plates (2) over arch assembly (3).
3. Align arch assembly (3) and header assembly end plate holes (4) and insert quick release pin (5).
4. Lay assembly on the ground. Repeat procedures for each arch assembly.

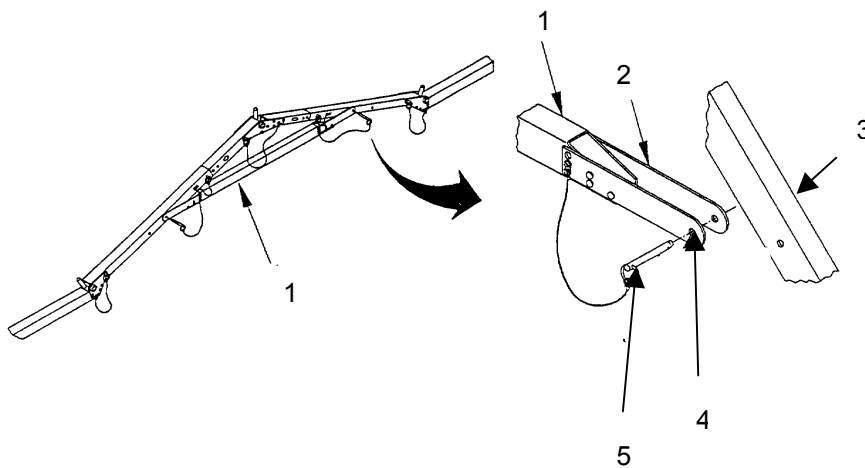

**Purlin Assembly.****NOTE**

An 8-foot section of the frame will be completed with five purlins.

1. Identify five purlins **(1)** for installations at the ridge **(2)**, eaves **(3)**, and bases **(4)**.
2. Starting at the end arch, hold two arch assemblies **(5)** upright and 8-feet apart, in the kneeling position.
3. Install purlin **(1)** at the ridge.

**NOTE**

Ensure arch assemblies are parallel for ease of installation of remaining purlins.

4. Identify the end fitting **(6)** on each end of the purlin **(1)**.
5. Insert the end fitting **(6)** in each arch assembly boss **(7)** simultaneously. When inserting the end fitting, rotate the purlin **(1)** 90° so that end fittings **(6)** lock into boss **(7)** at each arch assembly **(5)**.

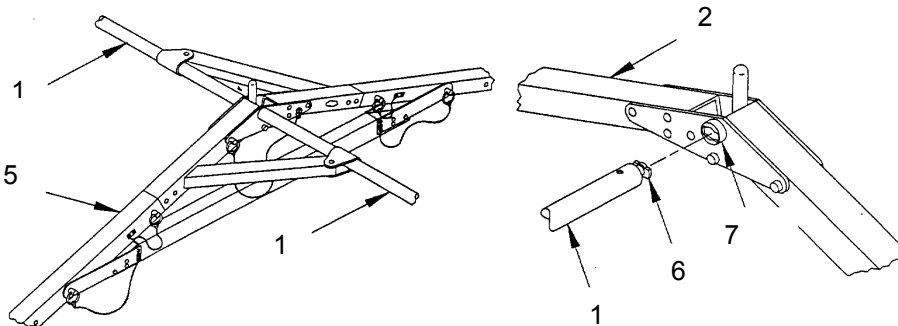

6. Unfasten the retaining strap **(8)** and rotate the purlin diagonal brace **(9)** toward the arch assembly **(5)**.

**NOTE**

The brace stud and brace shackle are located at the end of the purlin diagonal brace. The slot on the arch assembly is approximately two feet away from the ridge.

7. While holding the brace shackle **(10)**, align and place the brace stud **(11)** in the arch assembly slot **(12)** located two feet from the ridge.
8. Rotate the brace shackle **(10)** 90° to lock the brace stud **(11)** in place.

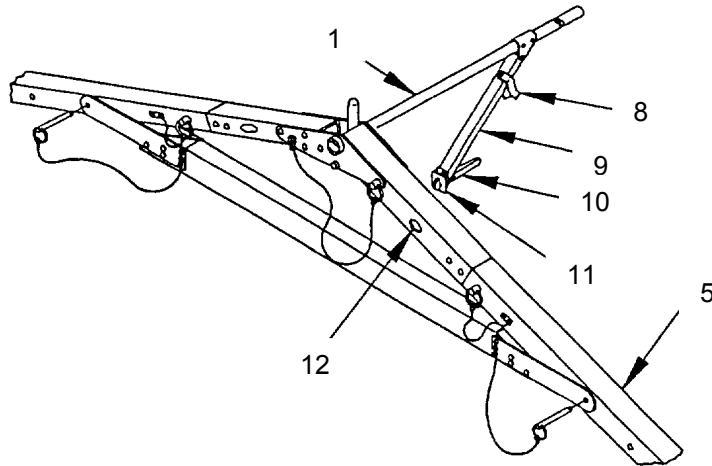

**WARNING**

Do not lock brace shackle toward purlin diagonal brace. Arch assembly may collapse causing injury to personnel or damage to equipment, if improperly locked.

9. Lock purlin diagonal brace (9) by pressing the brace shackle (10) down towards arch assembly (5) until it is secure.

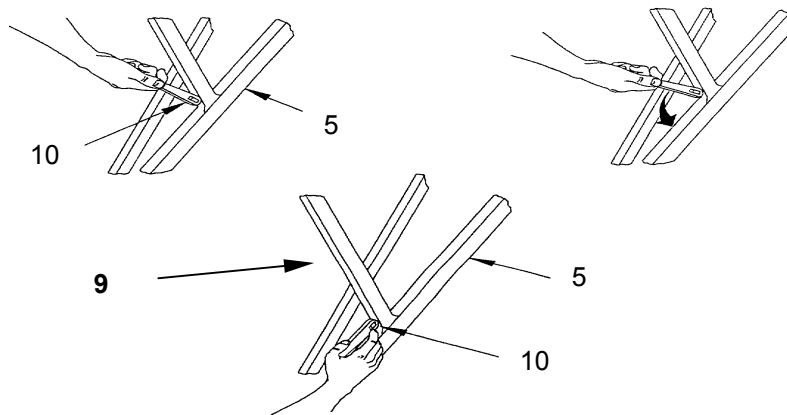

10. Install the remaining purlins (1) moving to the eave (3) and then to the base (4), using steps 4 through 9 above.

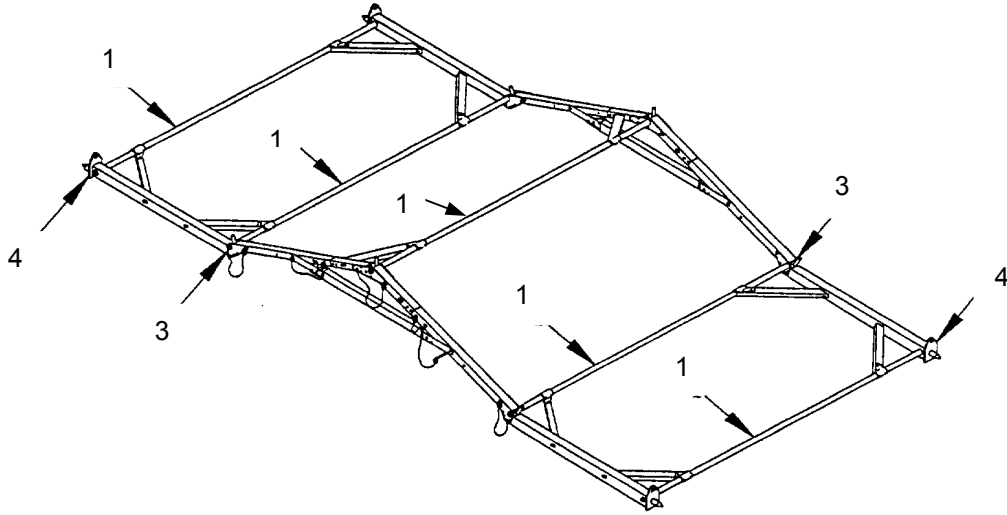

**Placement of Window Section.**

**NOTE**

Four soldiers are required to carry the window section to the frame. Install window section as follows:

1. Identify the window section (1).

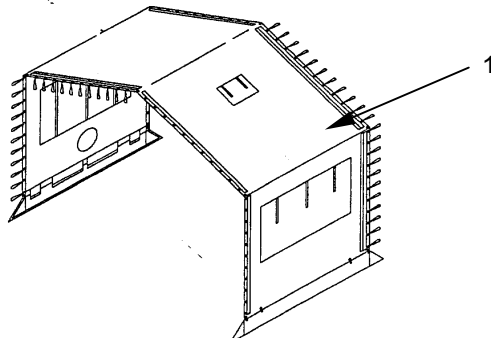



2. Place the window section (1) next to the extendable frame (2).
3. Identify large, spindle grommets (3) at the center of each side of the window section (1).
4. Place the large spindle grommets (3) over the ridge spindles (4).
5. Unroll the tent fabric until the fabric reaches the eave spindles (5). Place grommets over each of the four eave spindles (5).

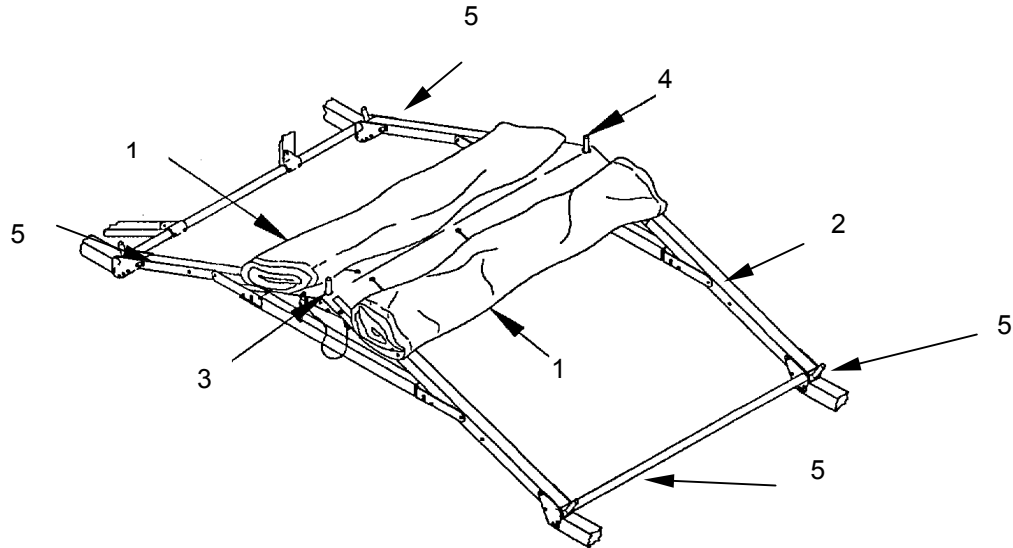

**Placement of ISO Modified End Section.**

**NOTE**

It is important that the ISO Modified End Section be placed on the side of the frame assembly facing the CSSL. The modified end section connects to the CSSL at a later stage.

1. Identify ISO Modified End Section (1). Identify large spindle grommet (2) at peak of modified end section. Modified end section should be stenciled "ISO Bootwall".

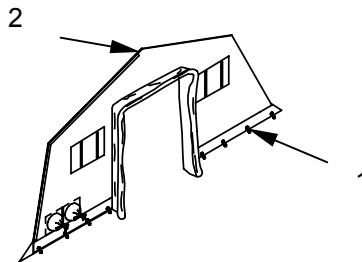

2. Place large, spindle grommet (2) (see illustration above) located at peak of modified end section (1) over ridge spindle (3) facing the CSSL.

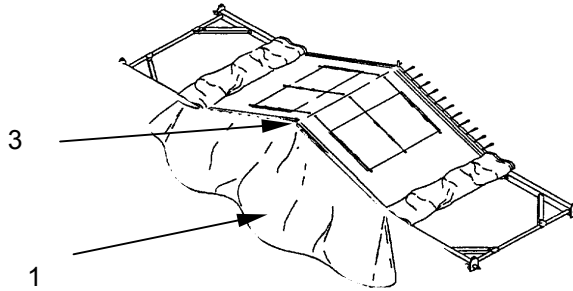

**Placement of End Section.**

1. Identify the end section (1). The regular end section has zip doors (2).

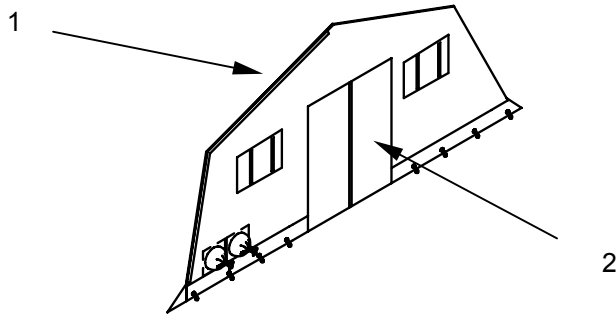

2. Place large, spindle grommet (3) located at peak of modified end section (1) over ridge spindle (4) away from the CSSL.

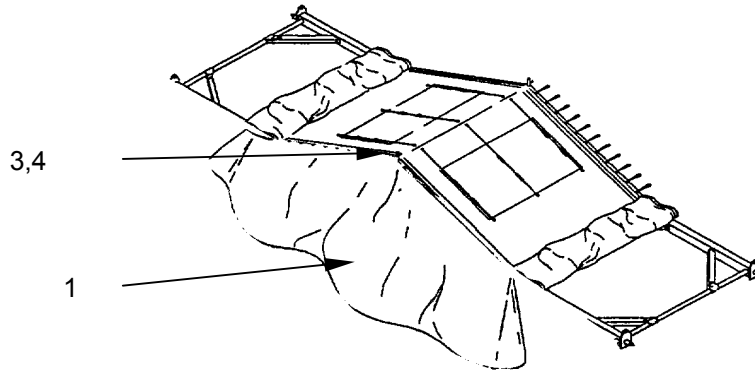

3. Identify the ridge extender (5).
4. Place the ridge extender (5) over the ridge spindle (4) away from the CSSL. Align holes in ridge spindle (4) and ridge extender (5).
5. Install the attached hitch pin (6) through holes in ridge extender (5) and spindle (4), ensuring it secures the ridge extender (5) to spindle (4).

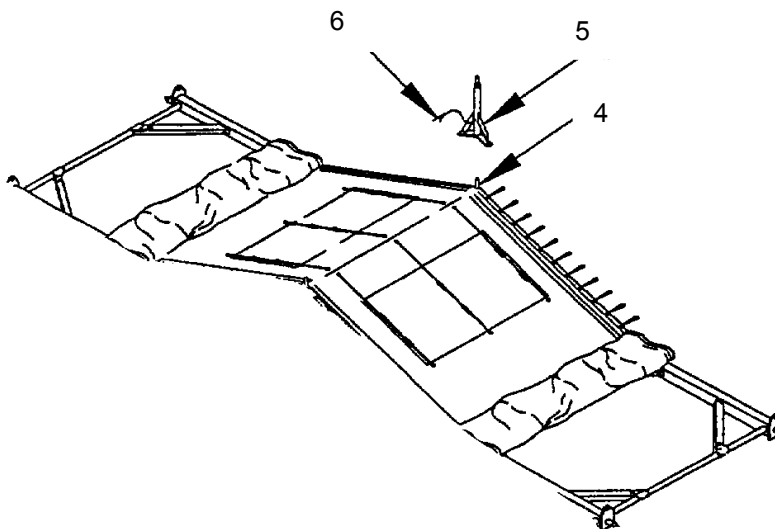

### Becket Lacing Window and End Sections.

At this point, lacing together of window and end sections may be accomplished simultaneously. Begin all lacing from the ridge line and work towards the eave. Becket lacing procedure is the same throughout the erection process and is accomplished as follows:

#### CAUTION

Do not step on tent components. Material may be torn and dirt ground into material.

1. Place the becket side eave grommet (1) over the eave spindles (2).

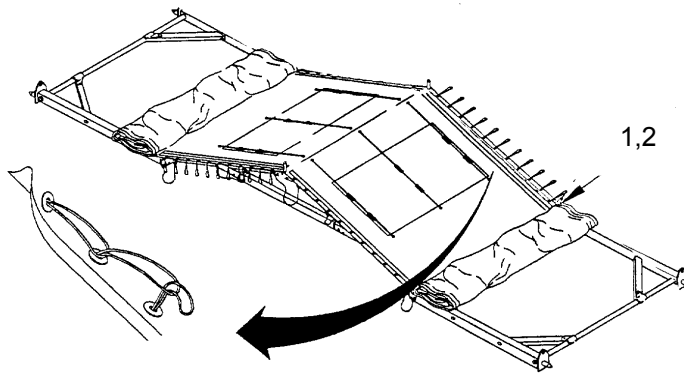

#### NOTE

For easier lacing, place eave grommets with becket laces over eave spindles first, to provide fabric tension, then overlap adjoining window section and end section eave grommet without laces.

2. Identify the first becket lace (3) and the becket grommet (4) near the ridge.
3. Insert the first becket lace (3) through the first becket grommet (4) and the second becket lace (5) through the second becket grommet (6).
4. Insert the second becket lace (5) through the loop of the first becket lace (3).
5. Pull the second becket lace (5) tight away from ridge.
6. Insert the third becket lace (7) through the grommet (8) and through the loop of the second becket lace (5).
7. Pull the third becket lace (7) tight away from the ridge.
8. Continue lacing and close hook and pile weather flap (9) until reaching the last becket lace (10).

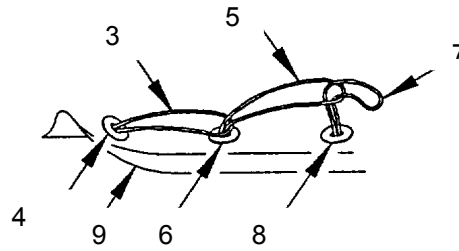

### NOTE

Ensure weather flap fabric is slid under the ridge extender brace.

9. Place the remaining window and end section grommets over the eave spindles.
10. Upon reaching the last becket lace (**10**) at the eave, insert the next-to-last becket lace (**11**) through the loop of the last becket lace (**10**).
11. Pull the next-to-last becket lace (**11**) back towards the ridge and tie off with a half-hitch knot.
12. Complete lacing all window and end sections up to the eave.

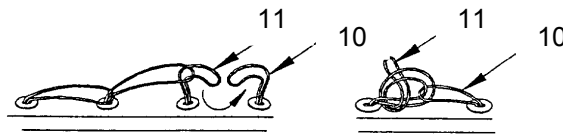

13. Identify the eave extenders (**12**).
14. Place the eave extenders (**12**) on the eave spindle (**2**) with the brace towards the ridge
15. Align the spindle (**2**) and eave extender (**12**) holes and insert the hitch clip pin (**13**) ensuring it secures the eave extender (**12**) to the eave spindle (**2**).

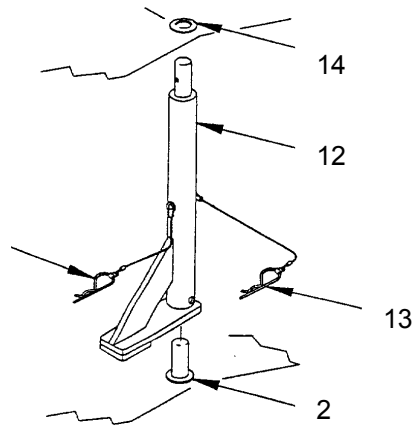

**NOTE**

At this time, do not lace any beackets below the eave.

**Install Guy Line.**

1. Identify one 19-foot guy line (1) and one tent slip (2) for placement at each of the four eave extender (3) bases.
2. Identify the 19-foot guy lines (1) and tent slips (2) for placement at the end ridge extender (4) base.
3. Thread the guy line (1) through one end of the tent slip (2) and then through the brace and around the pole of the eave (3) extender. Thread two guy lines through the ridge extender (4).
4. Bring the guy line (1) through other end of tent slip (2) and tie an overhand knot at the end of the guy line (1). Repeat steps above for all extenders.

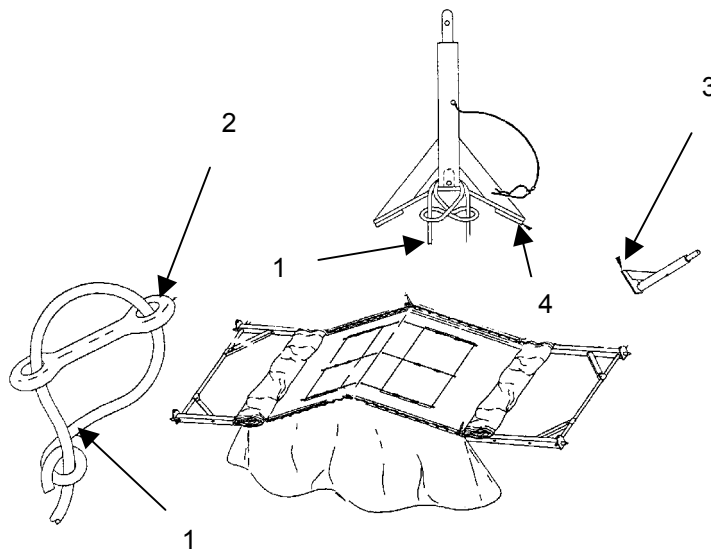

5. Thread the guy line (1) through one side of the tent slip (2) and then through the brace and around the pole of the eave (3) extender. Thread two guy lines through the ridge extender (4).
6. Bring guy line (1) through other side of tent slip (2) and tie an overhand knot at end of guy line (1). Repeat steps above for all extenders.

**Raising the Frame to Partially-Erect Position.**



**WARNING**

Eliminate the possibility of tripping. Clear fabric and guy lines. Injury to personnel may result from falls.

**CAUTION**

Avoid folding wall fabric into joints. Material may rip or tear if caught in joint.



**WARNING**

Two soldiers should be placed at each arch leg to raise frame. Lift tent from correct squatting position, using your legs to avoid back injury.

**Raise one side of the frame.**

1. Fold wall fabric (1) towards ridge (2) to expose eave gussets (3). Place folded fabric on ridge fabric (4).
2. Identify quick release pin (5) and ensure it is hanging free.
3. Identify the locking hole in the side arch assembly (6) and ensure it is free of debris.
4. Place one hand on the side arch assembly (6), and one hand on the eave purlin (7), outside the diagonal brace (8).

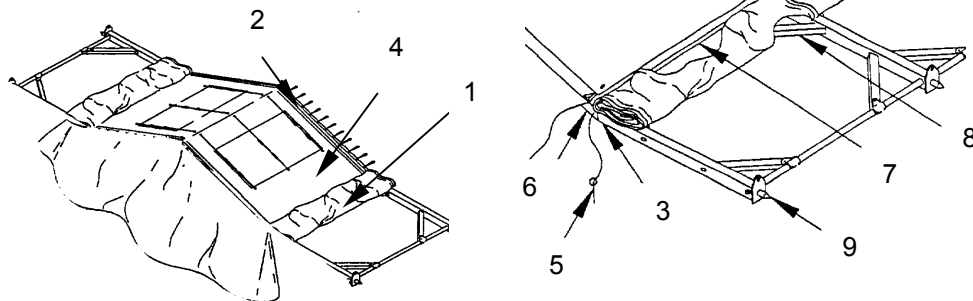

---

**CAUTION**

---

Tent frame must be raised uniformly to avoid twisting or turning. Damage to frame can result.



---

**WARNING**

---

Frame assembly hinges can pinch or crush hands and fingers. Keep hands and fingers away from frame assembly ridges and eaves. Failure to do so may result in injury to personnel.

---

**NOTE**

---

This illustration shows two window sections for clarity. Only one window section is used in the CSSL.

5. Step in next to the eave gusset **(4)** and get in a stable squatting position.
6. Lift the frame straight up to shoulder height; drag the side arch assembly **(6)** inward.
7. Place the weight of the frame on the side arch assembly foot **(9)**.

---

**CAUTION**

---

Insert quick release pins towards inside of tent on end assemblies. Tent fabric may tear if inserted towards outside.

8. Align holes of eave gusset **(4)** and side arch assembly **(6)** and install quick release pin **(5)**.
9. Identify purlin flap **(10)** on interior of window/roof section.
10. Secure purlin flap **(10)** to frame at eave purlin **(7)** using hook and pile fasteners. Tent is now in a partially-erect stage.



**NOTE**

The other side of the tent will be raised after installation of interior components.

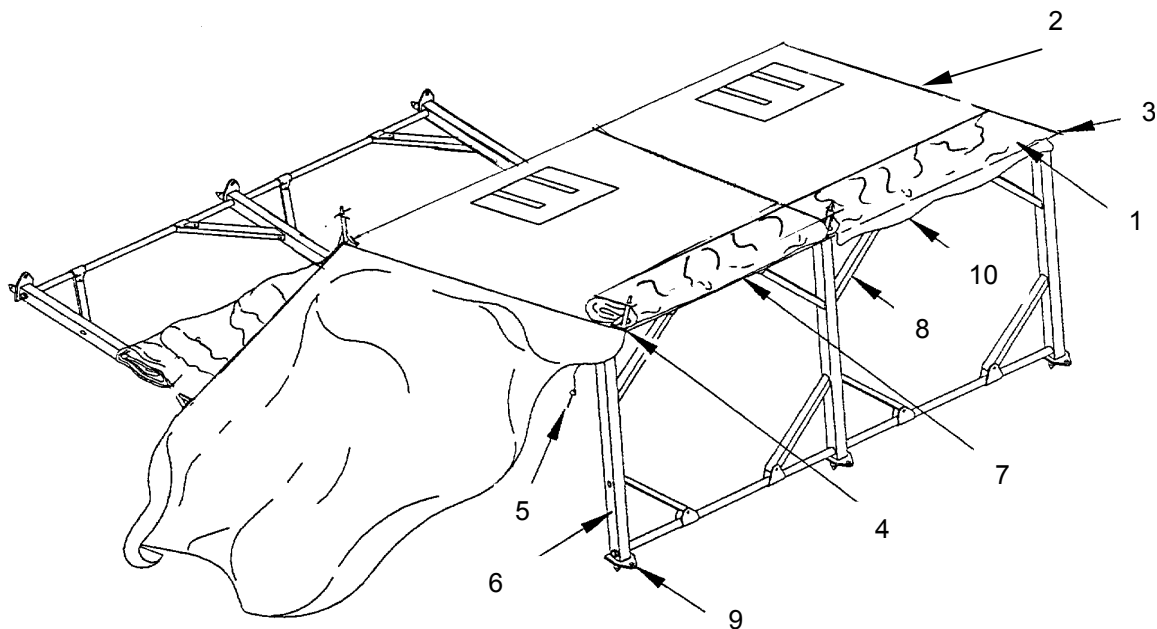
**Component Installation.**

While the frame is partially-erect, install light supports and lights as follows:

**WARNING**

Lethal voltage is present when cables are connected to power control system. Ensure cables are disconnected from power source when working with cables or fixtures. Electrical shock or death may result from failure to heed this warning.

**CAUTION**

Allow slack in electrical cables. Strain on cable can damage equipment.

1. Wrap extension cable (1) once around the header (2) to relieve strain.

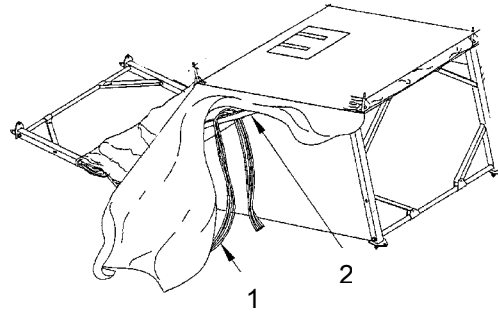

**WARNING**

Two personnel are required to lift light set case to avoid injury.

**NOTE**

To prevent damage, leave the lights in the case until ready to install. Be sure male plug end is toward the CSSL.

2. Identify light support strap assembly (1) in light set case.
3. Wrap each running end of light support strap assembly (1) once around header (2) at header/arch joint so the double D-ring (3) faces the tent roof.
4. Secure end of light support strap assembly (1) through double D-ring (3) assembly on standing end of strap. Tighten until the light support strap assembly (1) is taut.

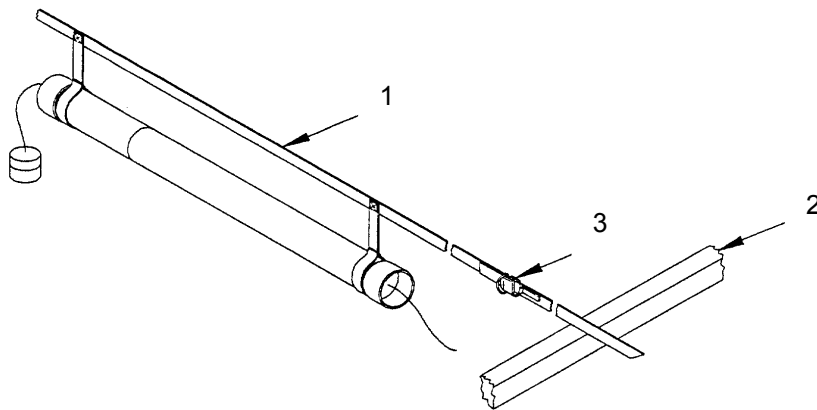

5. Wrap the light hanger strap (1) around each end of the light (2) on the inside of the rubber end caps (3).
6. Pull strap (1) up through the "D" ring (4) and press down to engage the hook and pile fastener (5).
7. Mate plug properly to next light (2), ensuring the reflecting surface faces up and the lamp faces down.
8. Repeat steps above for additional lights.
9. Repeat for second light on other side of TEMPER section. Plug the lights (2) together on the end opposite the CSSL.

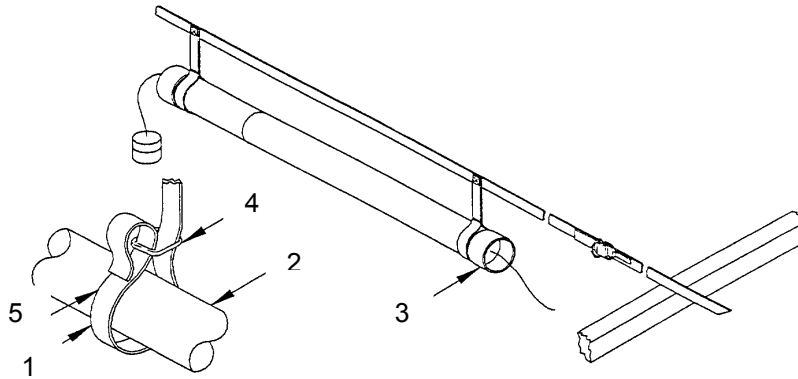

**Fully Erecting the Frame.****CAUTION**

Avoid folding wall fabric into joints. Material may rip or tear.

**NOTE**

This illustration shows two window sections for clarity. Only one window section is used in the CSSL.

1. Fold wall fabric **(1)** towards ridge fabric **(2)** and lay on roof **(3)** to expose eave gussets **(4)**.
2. Identify quick release pin **(5)** and ensure it is hanging free.
3. Identify the locking hole in the side arch assembly **(6)** and ensure it is free of debris.

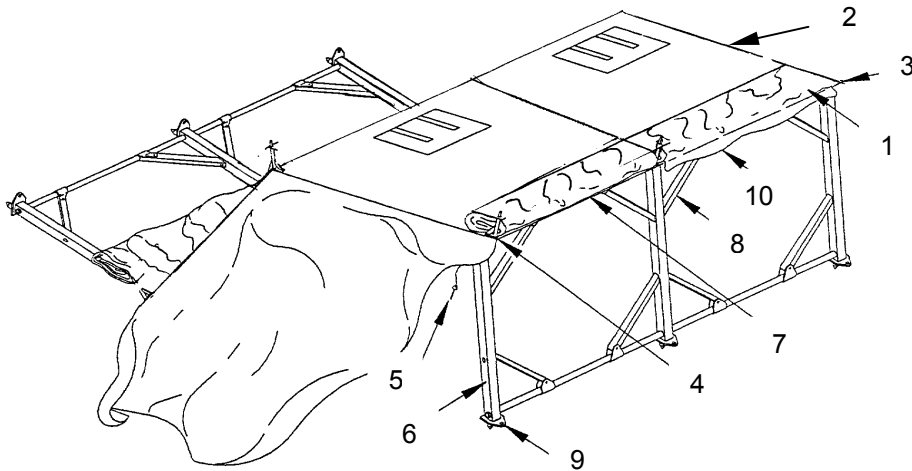



---

**WARNING**

---

Two soldiers should be placed at each arch leg to raise frame. Lift tent from correct squatting position, using your legs to avoid back injury.

---

**CAUTION**

---

Tent frame must be raised uniformly to avoid twisting or turning. Damage to frame can result



---

**WARNING**

---

Frame assembly hinges can pinch or crush hands and fingers. Keep hands and fingers away from frame assembly ridges and eaves.

4. Step in next to the eave gusset **(4)**.
5. Place one hand on the side arch assembly **(6)** and one hand on the eave purlin **(7)** outside the diagonal brace **(8)** and get in a stable squatting position.
6. Lift frame straight up to shoulder height, dragging side arch assembly **(6)** inward.
7. Place the weight of the frame on side arch assembly foot **(9)**.

---

**CAUTION**

---

Insert quick release pins towards inside of tent on end assemblies. Tent fabric may tear if pins are inserted towards outside.

8. Align holes of eave gusset **(4)** and side arch assembly **(6)** and install quick release pin **(5)**.
9. Identify purlin flap **(10)** on interior of window/roof section.
10. Secure purlin flap **(10)** to frame at eave purlin **(7)** using hook and pile fasteners.

---

**CAUTION**

---

Frame bases set more than 20 feet 4 inches apart may cause end section fasteners to tear apart.

11. Set frame bases (9) 20 feet 4 inches apart.

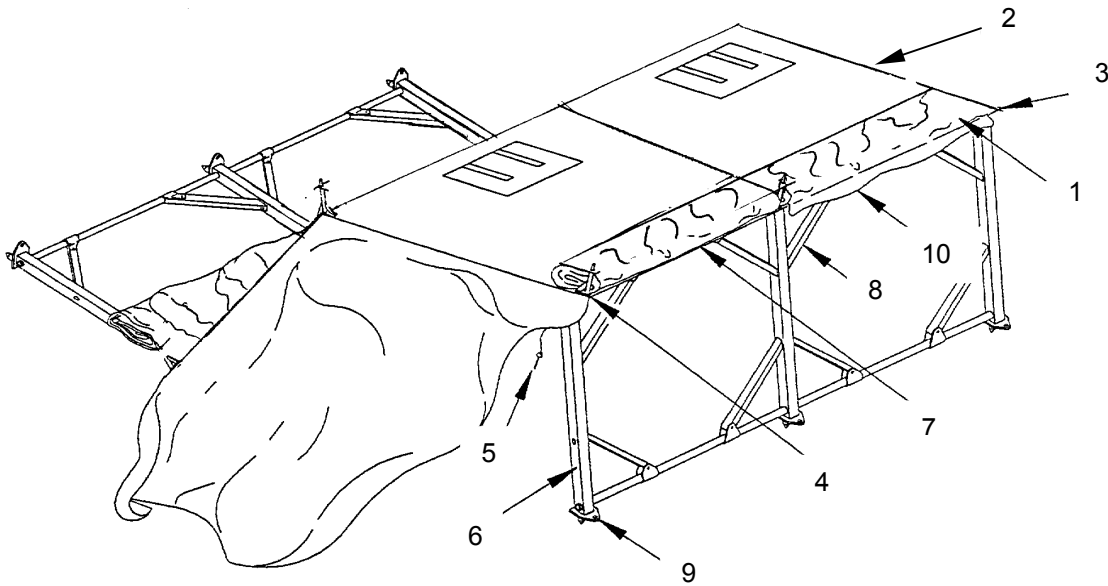

**Moving the TEMPER Section into Position.**



---

**WARNING**

---

The assembled TEMPER is heavy. At least four persons are required to move the TEMPER into position. To avoid injuries, ensure personnel are available before attempting to lift the tent. Personnel in the 5<sup>th</sup> percentile size group may require a step aid during this procedure.

1. Using four soldiers, one at each side arch assembly (1), pick up and move the TEMPER section against the CSSL, centering the ridge on the TEMPER section with the center of the closed personnel doors.

2. Have two soldiers gain access to the top of the CSSL using the hinged steps. Pull the Modified End Wall Boot (2) over the container end and lay loosely on the container roof.
3. Locate the two lines (3) attached to the ISO Modified End Wall fabric and pull them towards the opposite corners of the CSSL as shown. DO NOT FASTEN THESE LINES AT THIS TIME.

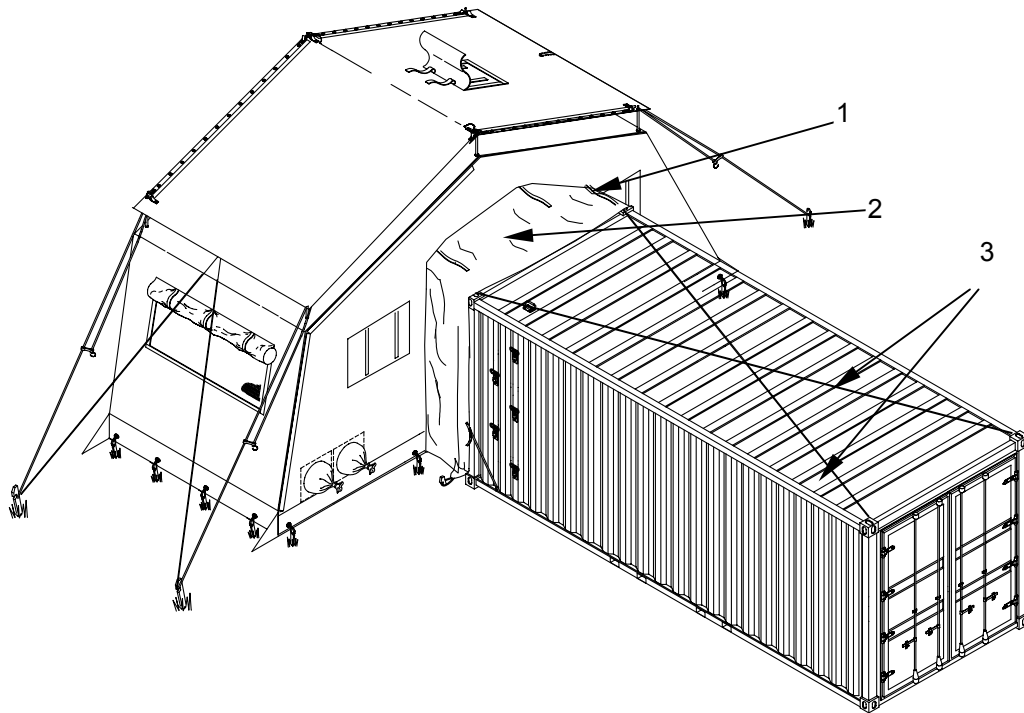

**Complete Becket Lacing and TEMPER Attachment.**

1. Roll up window flaps and secure. Have two soldiers on the ground complete lacing the window section (1) and the end sections (2) together. Secure weather seal flap (3).
2. Pull sod cloth (4) under base purlins (5) and end wall section (2).

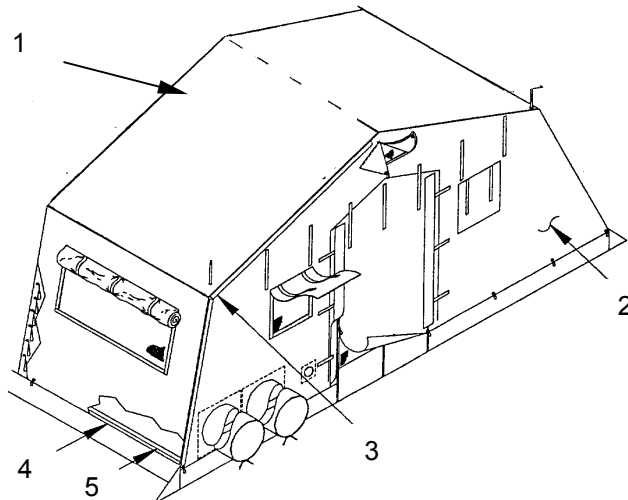

3. Have two soldiers on top of the container secure the boot lines (1) to the upper ISO fittings (2) at the opposite end of the container. Secure the lower end of the ISO Modified End Wall boot (3) to the ground with 12-inch steel pins (4).
4. Open the container end doors (5) and plug power cord for TEMPER interior lights into the GFCI outlet on the power entry box.

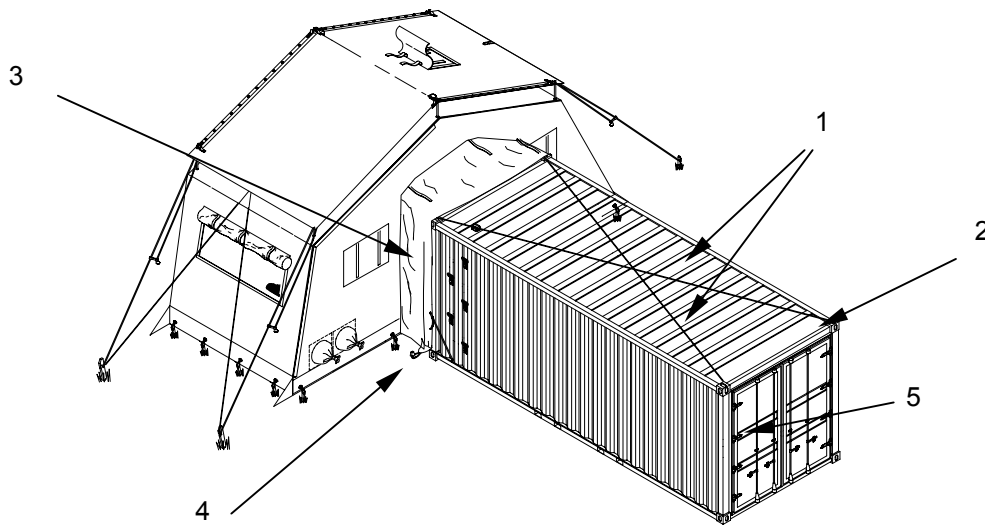



**Stakes and Guy Lines.****WARNING**

Stakes and guy lines must be used to prevent excessive movement of the tent section in high winds. Failure to stake and tie down tent section may result in personal injury or damage to equipment.

1. Place a 24-inch wooden stake (1) approximately 10 feet from the sides at the corners of the tent section at each eave extender and slant stake(s) towards the tent. Place two stakes (1) approximately 10-feet from the rear of the tent section at the ridge extender with stakes slanted towards tent.
2. Connect the loop of eave extender guy line (2) and the ridge extender guy lines (2) to bottom notch of wooden stake (1).
3. Place the loop of the fly guy line (4) over the top notch of the wooden stake (1).
4. Stake the tent frame foot to the ground using 12-inch steel pins (3). Stake foot loops (4) to the ground and tighten the guy lines (2).
5. Open the container doors back against the TEMPER wall, being careful not to hit the lights. Unfold the four tables and place them inside the TEMPER. Store the light set container under one of the tables.

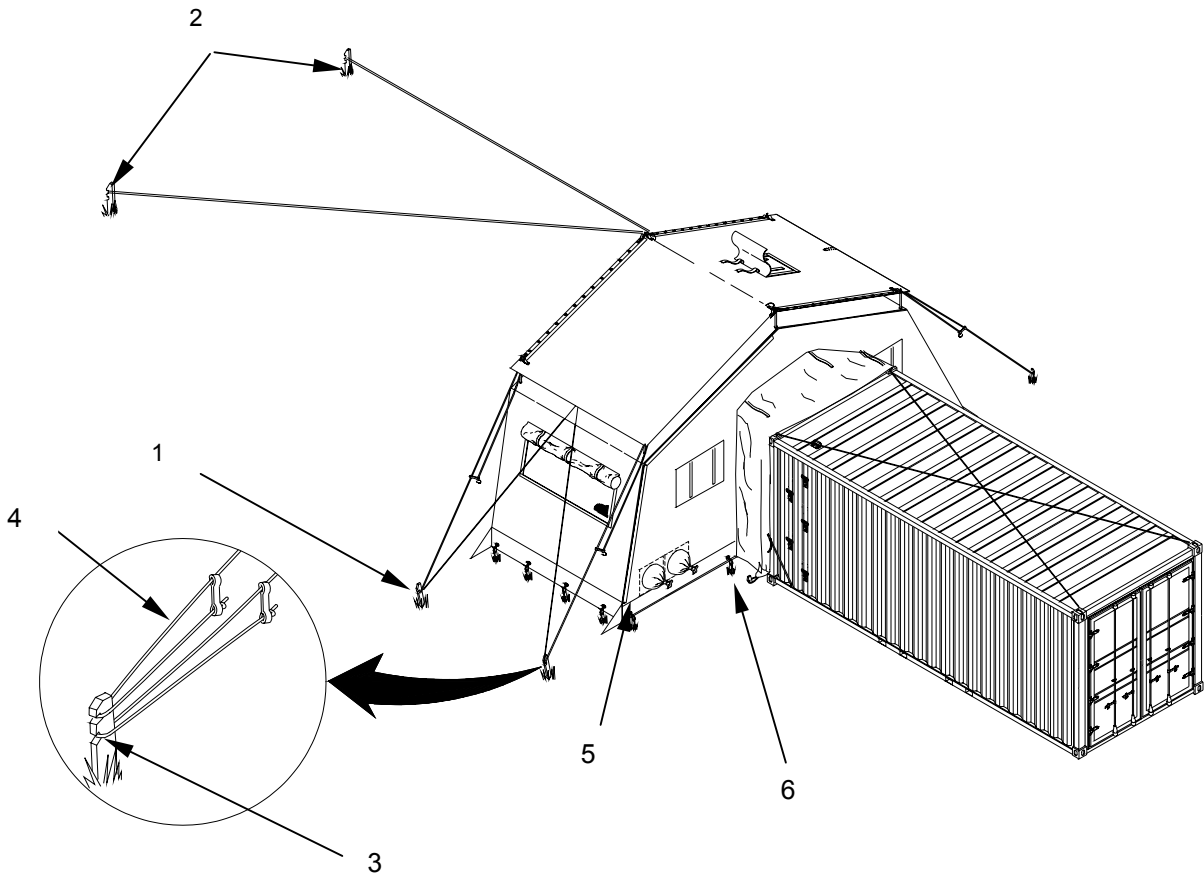

**OPERATE CSSL.**

After the power and freshwater supply connections are complete, and a wastewater collection/disposal site is connected, the CSSL can be operated.

1. In the Right Side Power Distribution Panel, set circuit breakers # 1, 3, 5, 7, 8, 10, 12, 15, 17, and 20 to ON
2. In the Left Side Power Distribution Panel, set circuit breakers # 6, 8, 10, 15, 17, and 18 to ON.
3. To use the interior lights, turn the light switch on the wall near the personnel door to ON.

**NOTE**

The freshwater pump is not used when the CSSL is connected to a municipal water system that supplies sufficient water pressure. However, when a static supply, such as a 3,000 Gallon fabric tank is connected, the freshwater pump must be used to provide water pressure.

4. To use the Freshwater Pump, set circuit breaker #3 in the Right Side Power Distribution Panel to ON.
5. Connect garden hose to the hose fitting **(1)** located at the end of the supply line (behind washer/dryer #6) and ensure the ball valve **(2)** is open. Set circuit breaker #3 on the right side Power Distribution Panel to ON. Start the freshwater pump **(3)** by lifting the lever **(4)** on the side of pressure switch **(5)** to override the shutoff. Hold lever until the pressure gage **(6)** indicates 20 lbs of pressure, then release lever. When water flows from end of the garden hose, close the ball valve **(2)**. After lever is released, the pressure tank **(7)** regulates the operation of the pump in accordance with the needs of the wash system. Disconnect the garden hose, drain and coil it, connect the ends together and place it in the footlocker.
6. If pressure gage **(6)** shows no pressure after pump has run for several minutes, refer to Unit Maintenance.
7. After the freshwater system has been activated, open the side doors **(8)** and check the water hose connections **(9)** behind washers for leaks. Hand-tighten any hose that leaks. If leak persists, notify Unit Maintenance. Close the side doors.

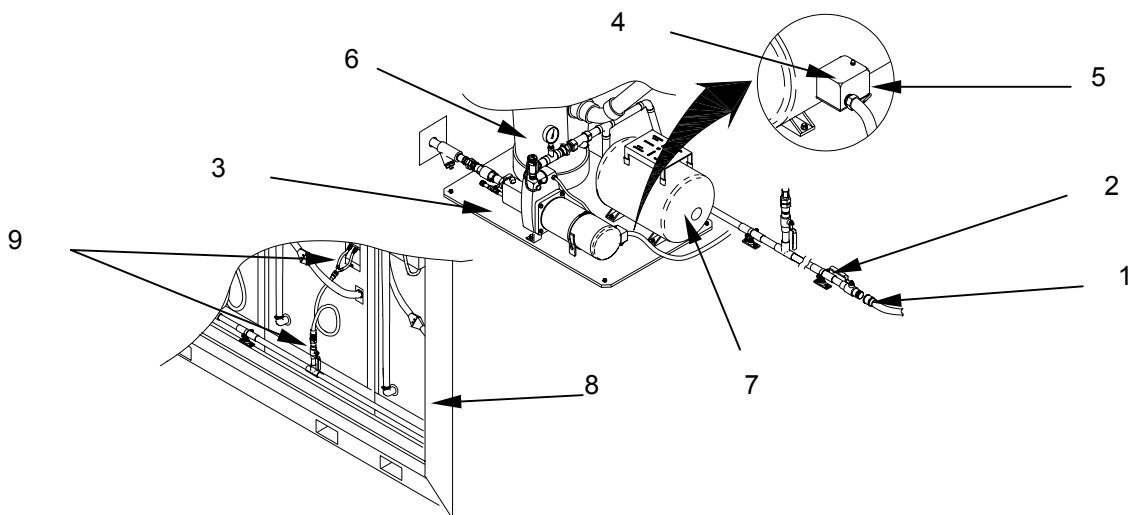

8. Before placing the CSSL in operation, test the operation of each washer/dryer by briefly activating the controls, and if the machine starts, resetting the controls. The CSSL is protected during long-term storage with non-toxic antifreeze. After testing, operate each washer for one complete regular cycle, to evacuate any residual antifreeze prior to using the laundry for clothing. After purging, operate washer/dryers as described in posted instructions.
9. To operate the space heater, set the circuit breaker # 15 in the Right Side Power Distribution Panel to ON and adjust the heater control knob until the heater comes on. The heater should not be operated while the washers and dryers are in operation.
10. Operate vent fan, by turning toggle switch located on the Right Side Power Distribution Panel to INTAKE or EXHAUST.

To operate the 3,000 Gallon collapsible fabric tank(s) refer to TM 5-5430-237-12&P. Operate the TEMPER as described in TM 10-8340-224-13.

During operation of the CSSL, frequently check the exterior dryer exhaust vent for free air flow.

#### **CSSL TEMPORARY SHUTDOWN.**

If the CSSL will not be needed for an extended period, it should be shut down temporarily.

#### **NOTE**

If the CSSL needs to be shut down because of unusual weather conditions, refer to work package 0006 00.



## WARNING

The CSSL components are heavy. To avoid injuries, four persons are required to perform this procedure.

To shut down the facility while it remains in place proceed as follows:

Ensure washer/dryers have completed their cycle.

### Using Municipal Water:

1. Shut off the fresh water supply at the source. Disconnect the 2" freshwater hose (1) from the source and from the fitting on the freshwater panel (2) on the utility wall of the container. Drain the hose, coil it, and set it aside.
2. Connect the garden hose (3) to the hose fitting (4) located at the end of the supply line (behind washer/dryer #6) and open (handle in line with water line) the ball valve (5) to let the system drain.
3. After the supply line has drained, disconnect the garden hose, drain it, coil it, connect the ends together and set it aside. Leave the ball valve (5) open (handle in line with water line).

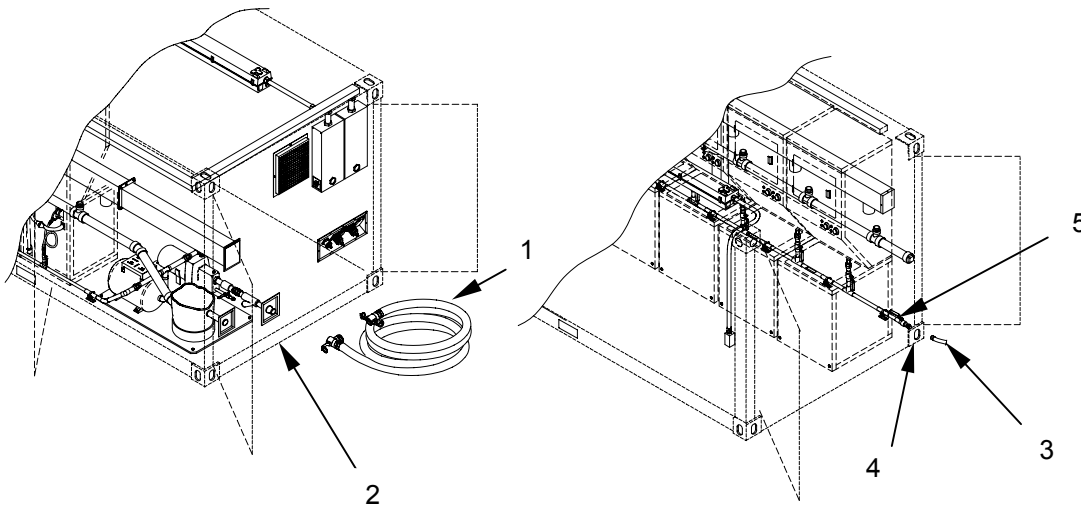

**Using a 3,000 Gallon freshwater tank:**

1. Shut off the freshwater pump **(1)** by setting circuit breaker # 3 in the Right Side Power Distribution Panel to OFF. Disconnect the 2" freshwater hose **(2)** from the freshwater inlet panel **(3)** on the utility wall. While holding the end of the hose above the water level in the freshwater tank **(4)**, place the end of the hose **(2)** into the freshwater tank as shown. Install dust cap **(5)** on panel **(3)**.
2. Connect garden hose to the hose fitting **(6)** located at the end of the supply line (behind washer/dryer #6) and open (handle in line with water line) the ball valve **(7)**. Leave the valve open after system has drained. Disconnect garden hose, drain and coil it, connect the ends together and set it aside.
3. Drain the 3,000 Gallon freshwater tank **(4)** in accordance with TM 5-5430-237-12&P. Remove the 2" freshwater hose **(2)** from the freshwater tank. Drain the hose, coil, and set it aside.
4. Place the coiled garden hose inside the CSSL. Coil and place 2" freshwater hose **(2)** together with 3,000 gallon freshwater tank **(4)** inside CSSL.

**PREPARE WASTEWATER COMPONENTS FOR SHIPMENT.****WARNING**

Avoid spillage of wastewater. Drain wastewater hoses into an approved disposal facility. Keep wastewater hoses away from freshwater hoses and any freshwater supply in the vicinity. Serious health problems may result from freshwater contamination.

**Using a municipal disposal system:**

1. After the sump pump **(8)** has stopped running, shut off the pump (Circuit Breaker #12, Right Side Power Distribution Panel).
2. Disconnect the 2" wastewater hose **(9)** from the wastewater panel **(10)** on the utility wall, and drain it into the disposal point. Disconnect 2" wastewater hose **(9)** from wastewater disposal point. Drain the hose, coil and set it aside.

**Using a 3,000 Gallon wastewater collection tank:**

1. Disconnect the 2" wastewater hose **(9)** from the wastewater panel **(10)** on the utility wall and hold the end of the hose above the water level in the 3,000 Gallon wastewater tank **(11)**. Place the end of the hose into the wastewater tank as shown.
2. Empty the 3,000 Gallon wastewater tank **(11)** in accordance with TM 10-5430-237-12&P. Remove the 2" wastewater hose **(9)** from the wastewater tank. Drain the hose, coil, and set it aside.
3. Clean out dryer lint traps **(12)** and dispose of lint. Clean CSSL and TEMPER as described in work package 0010 00.

4. Place 2" wastewater hose (9) and 3,000 Gallon wastewater tank (11) inside the CSSL.
5. Switch all individual and then the main circuit breakers in both power distribution panels (13) to OFF.
6. Close all window flaps on the TEMPER and slide fasteners around the entry. Close container side doors (14).

To re-activate the CSSL, follow the procedures under Prepare TEMPER with ISO Modified End Section for Use.

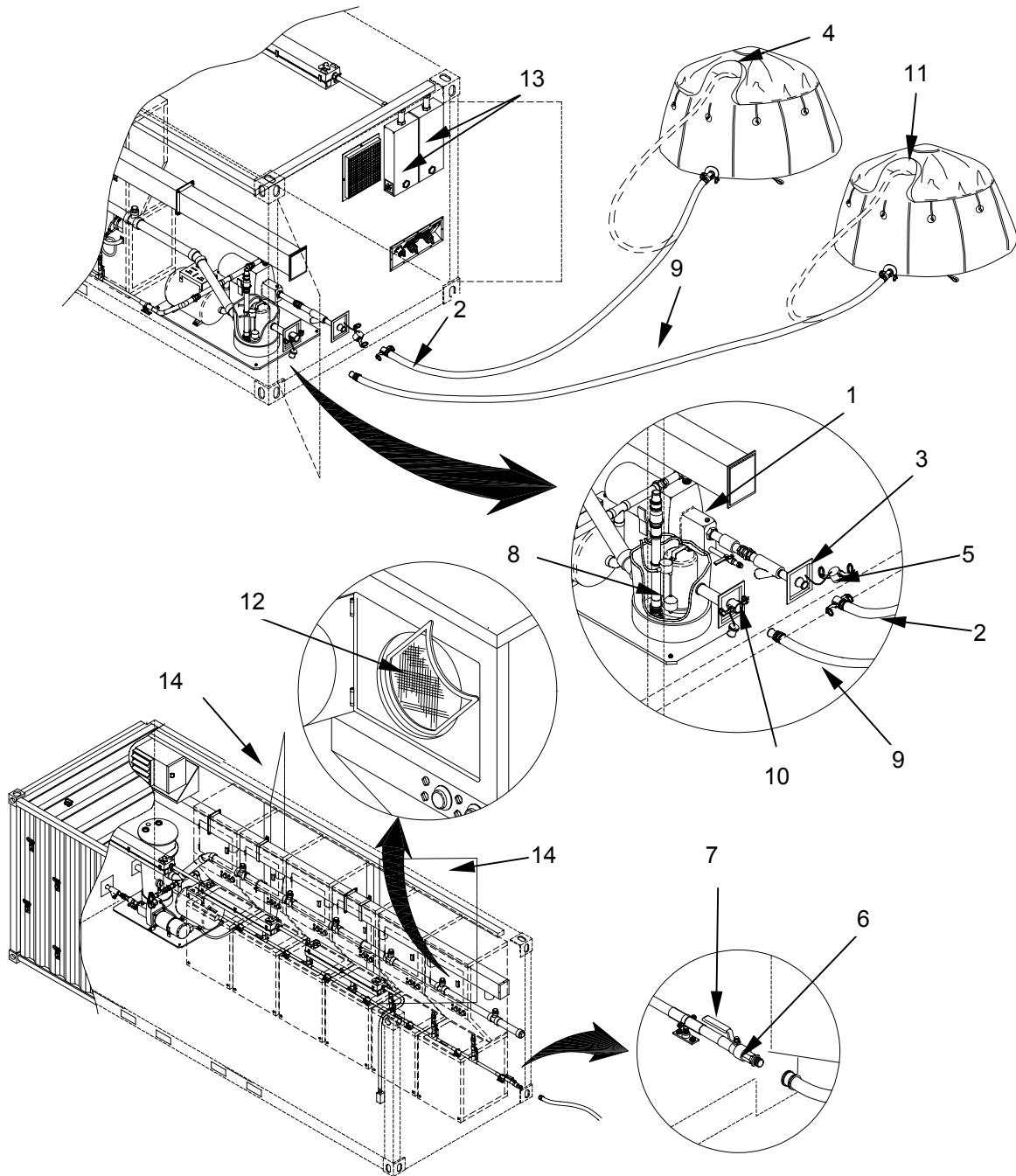

**PREPARE CSSL FOR RETURN SHIPMENT.**

When the CSSL is no longer required to support the mission, arrange for its return shipment to depot through command / support channels. Prior to shipment, close the facility and prepare it for shipment as described herein. Before proceeding, ensure all washer/dryer units have completed their cycle, are empty of all items and the wastewater pump is OFF before proceeding.

**WARNING**

The CSSL components are heavy. To avoid injuries, four persons are required to prepare the CSSL for shipment.

**PREPARE WASHERS AND DRYERS FOR SHIPMENT.**

1. Open washer/dryers **(1)** and remove any items that may have been left inside.
2. Clean out dryer lint screens **(2)** and replace them in the dryers.
3. Retrieve the washer shipping brackets **(3)** from on top of the dryers and install them into the washers.
4. Secure the dryer doors using tape **(4)** provided in the footlocker.

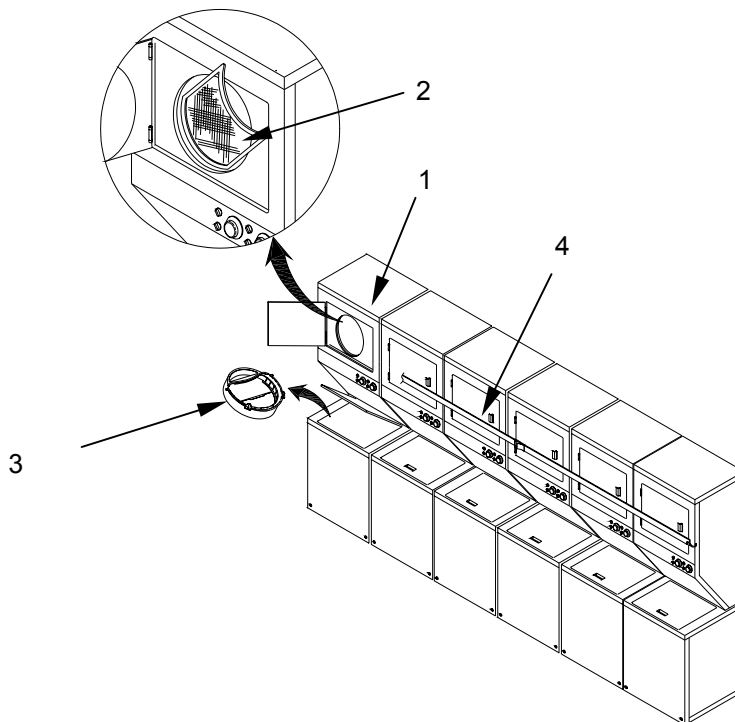

**PREPARE FRESHWATER COMPONENTS FOR SHIPMENT.****Using municipal water:**

1. Shut off the fresh water supply at the source. Disconnect the 2" freshwater hose (1) from the freshwater inlet panel (2) on the utility wall.
2. Connect the garden hose to the hose fitting (3) located at the end of the supply line (behind washer/dryer #6) and open (handle in line with water line) the ball valve (4) to let the system drain.
3. Leave the ball valve (4) open after system has drained. Disconnect the garden hose, drain and coil it, connect the ends together and set it aside.
4. Disconnect the 2" freshwater hose (1) from the water source, drain and coil it, and set it aside.

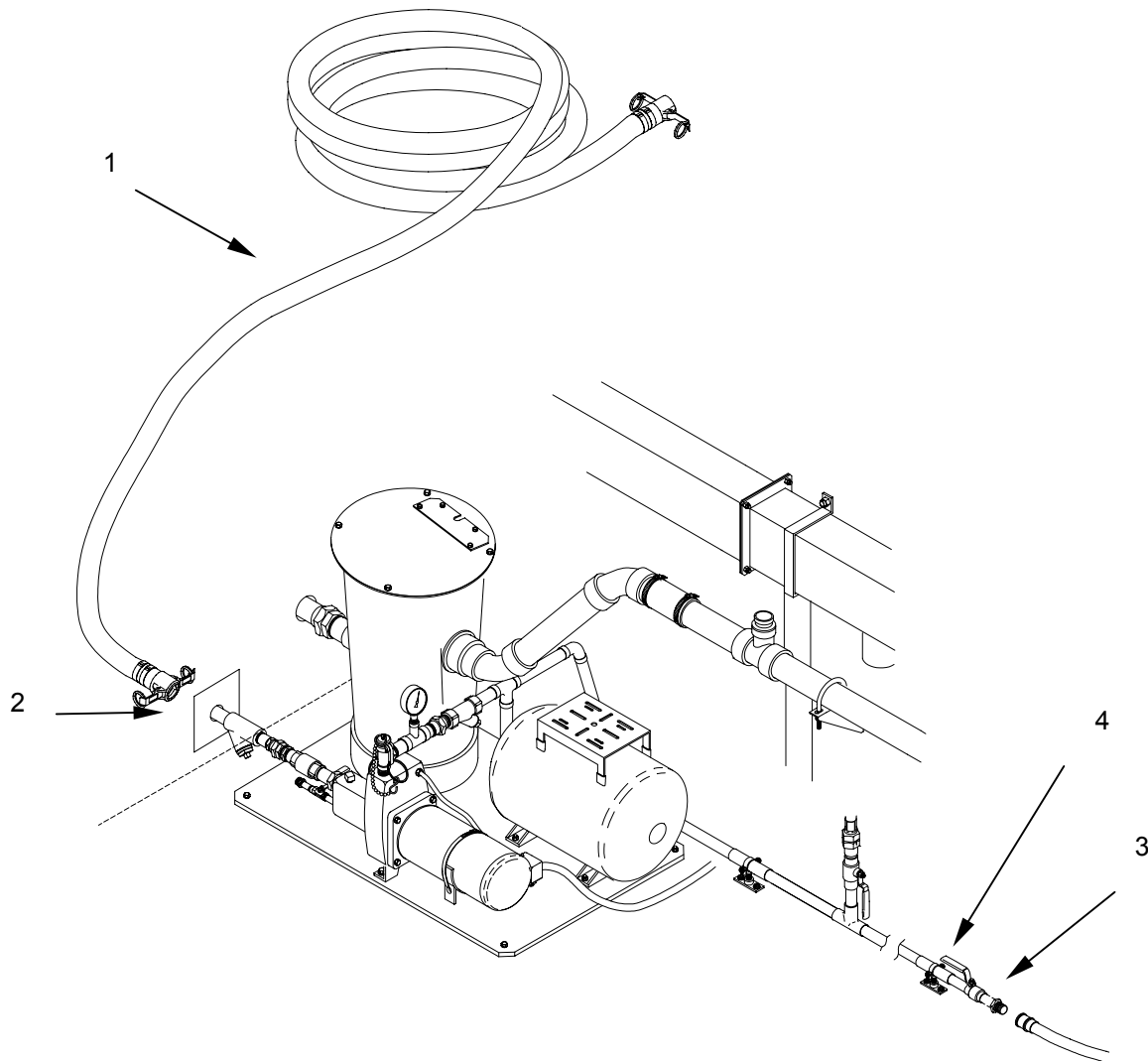



### Using a 3,000 Gallon freshwater tank:

1. Shut off the freshwater pump (1) by setting circuit breaker #3 in the Right Side Power Distribution Panel to OFF. Disconnect the 2" freshwater hose (2) from the freshwater inlet panel (3) on the utility wall. Hold the end of the hose above the water level in the freshwater tank (4) and place the end of the hose (2) into the freshwater tank as shown. Install dust cap (5) on panel (3).
2. Connect garden hose to the hose fitting (6) located at the end of the supply line (behind washer/dryer #6) and open (handle in line with water line) the ball valve (7) to let the system drain.



### WARNING

The 3,000 Gallon water tank is heavy. To avoid injuries, four persons are required to prepare the CSSL for shipment.

3. Drain the 3,000 Gallon freshwater tank (4) in accordance with TM 5-5430-237-12&P. Remove the 2" freshwater hose (2) from the freshwater tank (4). Drain the hose, coil, and set aside. Disassemble and place 3,000 Gallon freshwater tank (4) into cover in accordance with TM 5-5430-237-12&P.
4. After water line has drained, disconnect garden hose from the hose fitting (6). Leave ball valve (7) in open (handle in line with water line) position after system has drained. Drain the hose, coil it, connect the ends together and set it aside.

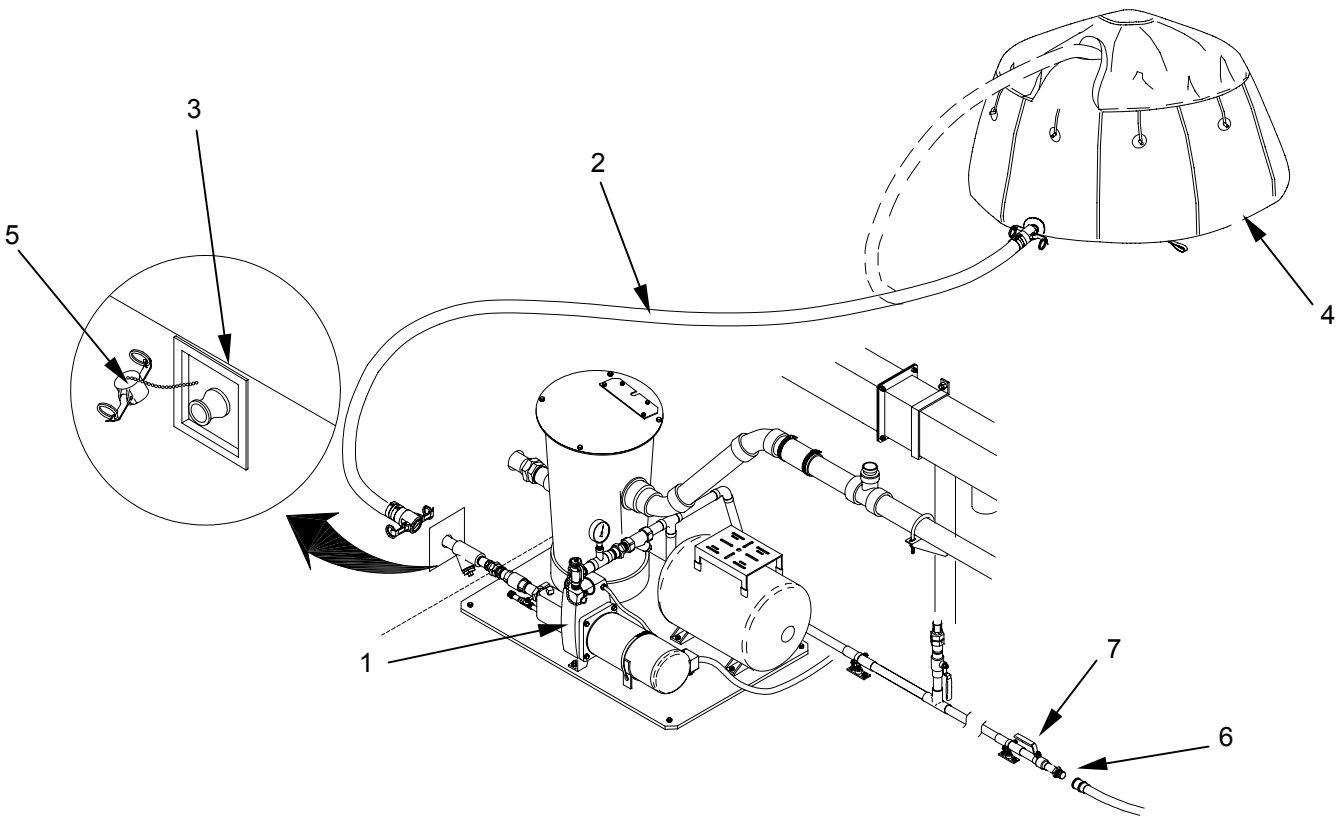

**PREPARE WASTEWATER COMPONENTS FOR SHIPMENT.****WARNING**

Avoid spillage of wastewater during preparation for movement. Drain wastewater hoses into an approved disposal facility. Keep wastewater hoses separate from freshwater hoses.

**Using a municipal disposal system:**

1. After the sump pump (1) has stopped running, shut off the pump (Circuit Breaker #12, Right Side Power Distribution Panel).
2. Disconnect the 2" wastewater hose (2) from the wastewater panel (3) on the utility wall, and drain it into the disposal connection. Disconnect 2" wastewater hose (2) from wastewater disposal point. Drain the hose, coil and set it aside. Install dust cap (4) on panel (3).

**Using a 3,000 Gallon wastewater collection tank:**

1. Disconnect the 2" wastewater hose (2) from the wastewater panel (3) on the utility wall. While holding the end of the hose (2) above the water level in the 3,000 Gallon wastewater tank (5), place the end of the hose into the wastewater tank (5). Install dust cap (4) on panel (3).

**WARNING**

The 3,000 Gallon water tank is heavy. To avoid injuries, four persons are required to prepare the CSSL for shipment.

2. Empty the 3,000 Gallon wastewater tank (5) in accordance with TM 10-5430-237-12&P. Remove the 2" wastewater hose (2) from the wastewater tank. Drain the hose, coil it and set it aside.
3. Disassemble and place 3,000 Gallon wastewater tank (5) into its cover in accordance with TM 10-5430-237-12&P.

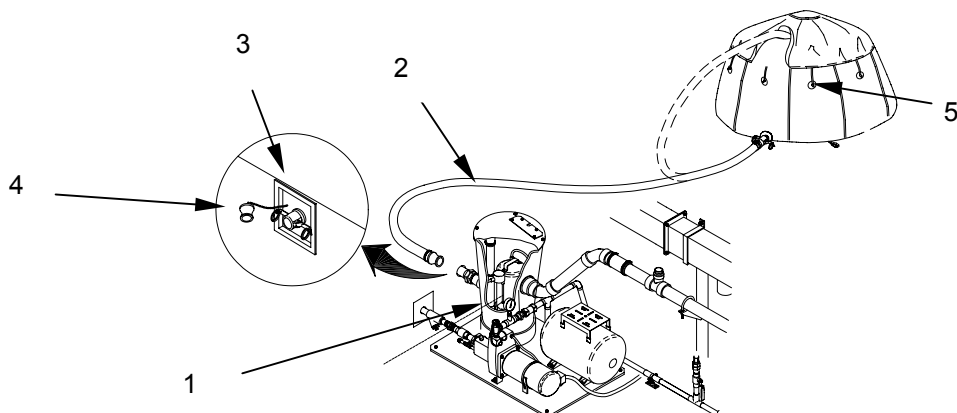

### PREPARE TEMPER WITH MODIFIED END SECTION FOR SHIPMENT.

To prepare the TEMPER section for movement, follow the procedures outlined. Clean and dry the tent fabric sections and equipment as described below. Package the tent frame pieces into the TEMPER frame section cover.

### CAUTION

Use caution when closing CSSL doors to avoid damage to lights. CSSL doors are heavy and can break lights.

#### Striking procedures.

1. Locate the frame section cover and the light set storage container, close the personnel double doors, then proceed as follows:
2. Have two soldiers gain access to the top of the container and loosen the boot lines (1) to the upper ISO fittings (2) at the opposite end of the container. Have two soldiers on the ground remove the tent stakes (3) from the lower end of the boot (4).
3. Have the soldiers on top of the container fold the boot back towards the TEMPER section and coil the boot lines (1).

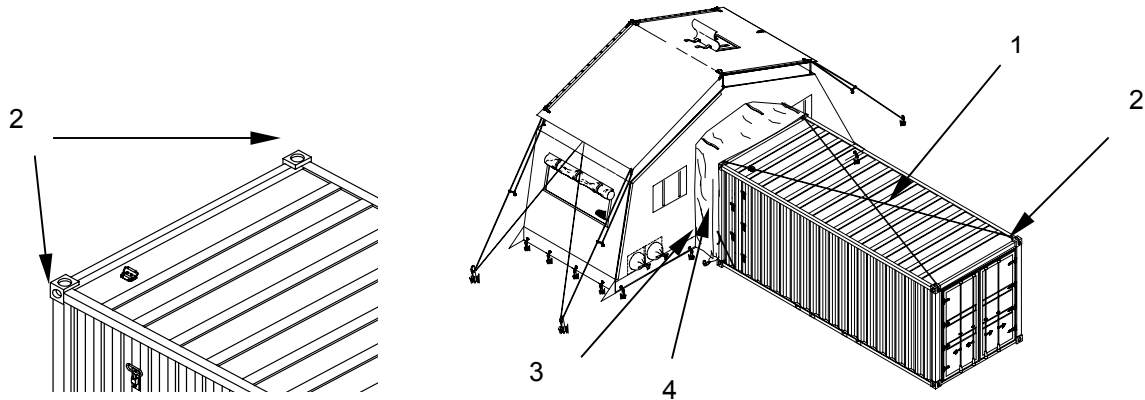

### WARNING

Lethal voltage is present when cables are connected to the power control system. Ensure cables are disconnected from the power source when working with cables or fixtures. Electrical shock or death may result from failure to heed this warning.

4. Have a soldier on the ground unplug the power cord used for TEMPER interior lights from the container power panel. Disconnect the cord from lights, coil the cord, and place it in CSSL footlocker.
5. Release tension from both guy lines at the ridge **(1)** and disconnect them from the wooden stakes **(2)**.
6. Remove the stakes **(2)** at the rear of the TEMPER section and then remove all steel tent pins **(3)**.
7. Release tension from the guy lines **(6)** at eaves and disconnect them from the wooden stakes **(2)**.
8. Remove all remaining wooden stakes, clean them and place them in their bags.
9. Disconnect all becket laces **(4)** up to the eave.
10. Close all the windows and doors on all fabric sections.
11. Lift the fabric **(5)** from the side of the tent and roll it up onto the roof section.

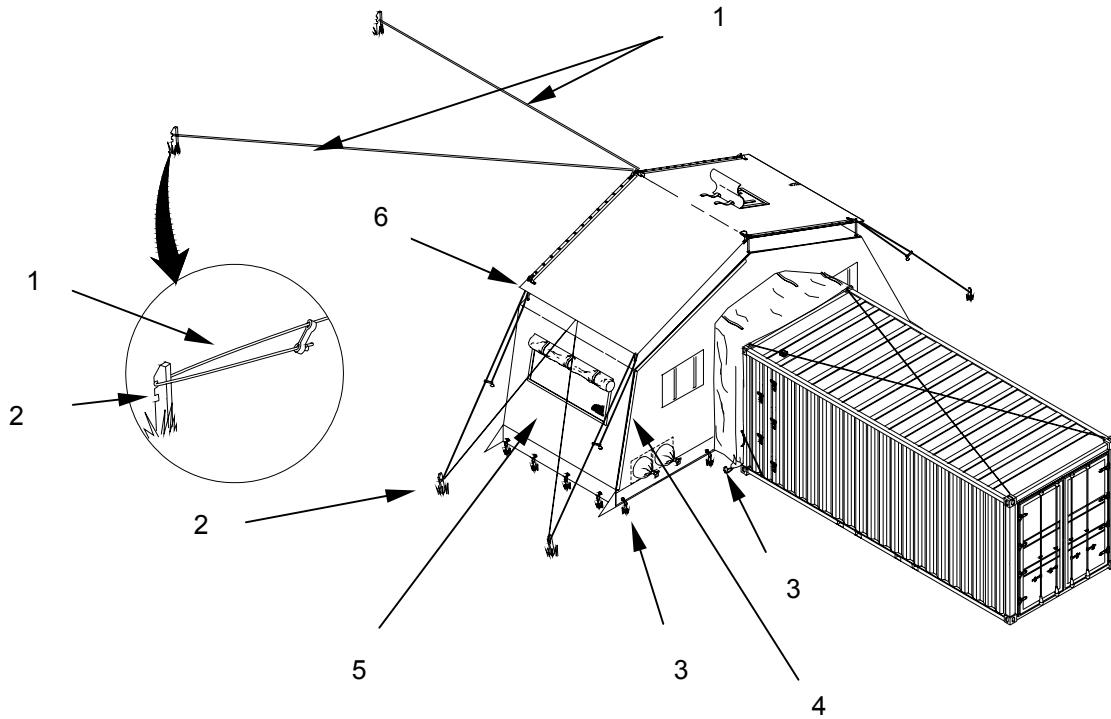

**WARNING**

The assembled TEMPER section is heavy. At least four persons are required to move the TEMPER away from CSSL. To avoid injuries, ensure personnel are available before attempting to lift the TEMPER Section.

12. Using one soldier at each of the four corners, move the TEMPER section away from the CSSL approximately four to six feet.

**Lowering the Frame.****WARNING**

Frame assembly hinges can pinch or crush hands and fingers. Keep hands and fingers away from frame assembly ridges and eaves.

**CAUTION**

Avoid folding wall fabric into joints. Material may rip or tear if caught in joint.

1. Place two soldiers at each arch **(1)** on side of tent being lowered.
2. On command, remove quick release pins **(2)** holding arches erect.

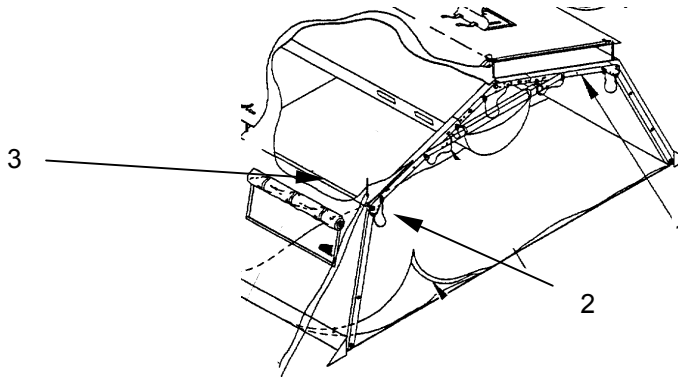
**CAUTION**

Do not twist or turn frame components when handling. Damage to equipment may occur.

3. Standing clear of the tent section, place one hand below the eave joint of the arch **(1)** and one hand on the eave purlin **(3)**.
4. Swing the side frame out and lower the side. Extra soldiers may assist in lowering frame.
5. Remove the lights from inside the tent section.
6. Remove the light strap assemblies.
7. Store the light components in the retrieved light case.

8. Disconnect the eave purlin flaps.

Repeat these steps to lower the other side of the tent section.

### Removing the Fabric.

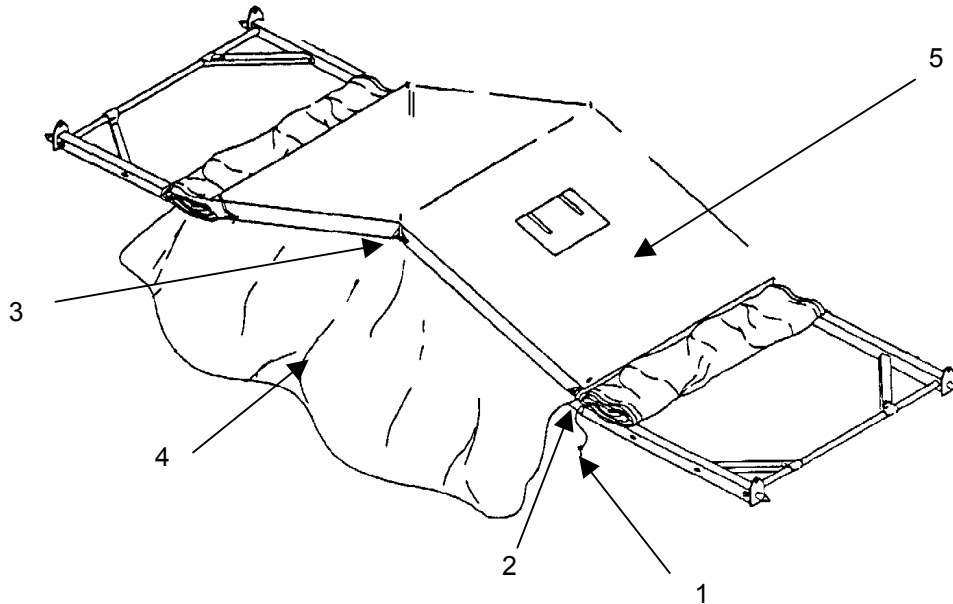

1. Disconnect the hitch clip pins **(1)**, from the eave extenders **(2)** and remove the eave extenders **(2)**.
2. Untie tie off point and disconnect becket lacing of roof section.
3. Remove the hitch clip pin from the ridge extender **(3)** and remove the ridge extender **(3)**.
4. Remove the ISO Modified End Section **(4)** and regular End Section on the opposite side of the frame.

### NOTE

Fold the window section fabric, label side out.

5. Remove the window section **(5)** from the frame.
6. Clean and dry the window section if necessary. Fold and pack the window section in the window section cover.

**Frame Disassembly.****NOTE**

Frame disassembly sequence is from the base to the ridge.

1. Disconnect each purlin diagonal brace (1), fold it and secure it with the attached strap.

**WARNING**

Position one soldier at each ridge arch to hold arch upright during frame disassembly. Failure to hold frame upright may allow the frame to fall and cause injury to personnel.

2. Rotate the purlins (2) and remove them.
3. Remove the quick release pins (3) and remove the headers (4).
4. Disassemble the roof arch (5) and side arch assemblies (6) and fold them.
5. Pack the frame components in the TEMPER frame section cover assembly.

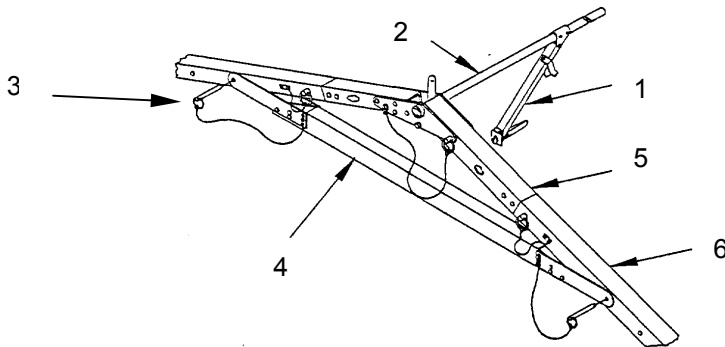



**PREPARE POWER DISTRIBUTION SYSTEM FOR SHIPMENT.****WARNING**

Power source must be shut down/secured before disassembling any cables to prevent electrical shock.

**NOTE**

This procedure can only be performed by qualified civilian or military personnel in MOS 51R, 52C, 52D, or 52G.

1. Set all individual and then the main circuit breakers in both power distribution panels **(1)** to OFF. Turn power source OFF. Disconnect 100 AMP Supply Cables **(2)** from the power entry panel **(3)** and from the power source.
2. Disconnect power cables, if being used, from the 110 VAC GFCI Utility **(4)**, 30 AMP twist-lock **(5)** and the 60 AMP Class L connector **(6)** on the power entry panel **(3)**.
3. Install dust covers on all power entry panel connectors and 100 AMP Supply Cables **(2)**. Coil the cables.
4. Disconnect the ground wire **(7)** from the ground terminal on the power entry panel **(3)**. Recover the ground rod **(8)**, disassemble it and clean it.

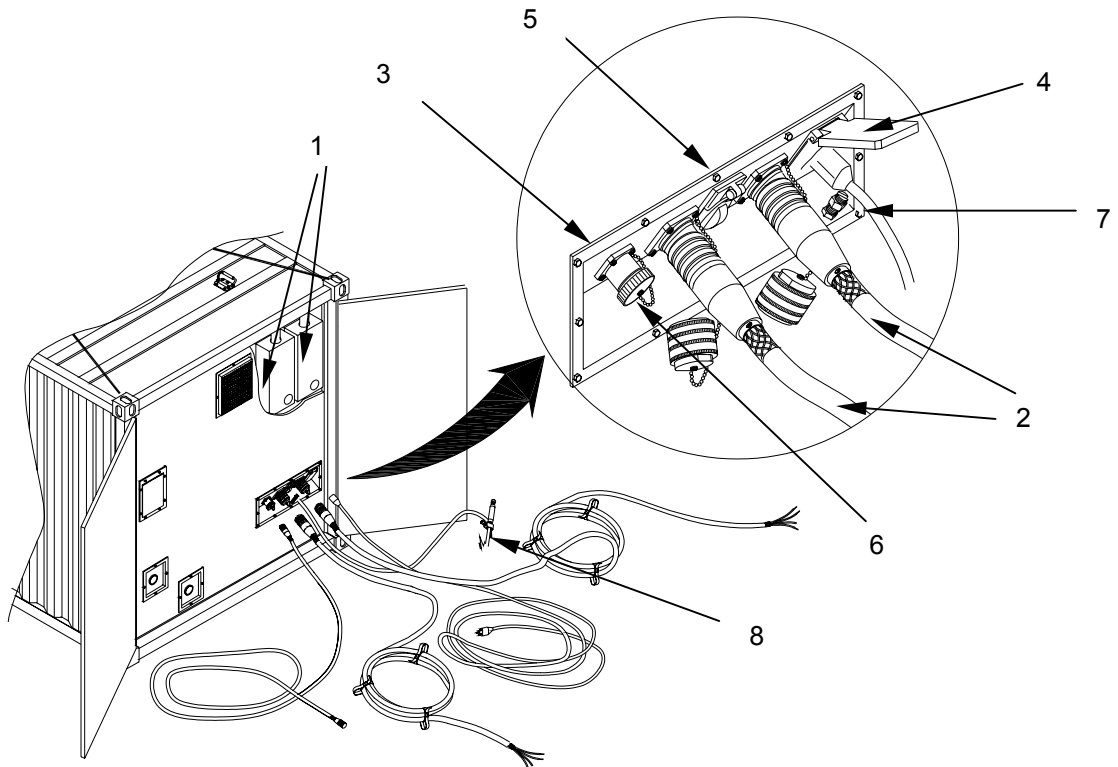

**PACKING CSSL FOR RETURN SHIPMENT.**

Before packing the CSSL container for return shipment, ensure that the inside has been swept clean and excess water has been mopped out. Ensure that the washer/dryers are empty of items and have completed their cycles. Tape washer/dryer doors shut with tape provided in footlocker.

**WARNING**

The CSSL components are heavy. To avoid injuries, observe the lift requirements shown in the table below.

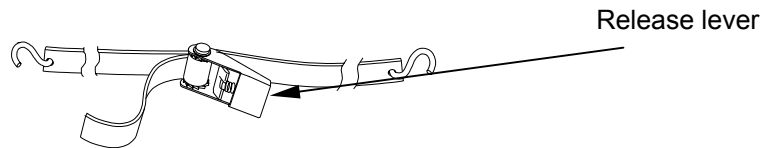

1. Thread the strap through the spool, work the release lever to tighten the strap. Ensure the floor tiedown attachments are not covered by packed items.
2. Pack the CSSL in the order shown in the following table. Identify and inventory items being packed using the table below and the packing plan on the following page. Retrieve the tie-down straps from footlocker and secure the items as shown. Place Technical Manual into the footlocker when finished. Close and secure all doors.

Nomenclature	Quantity	Condition	Lift Requirements
Wastewater Tank,3,000 gallon	1	Drained, clean and folded	4 Persons
TEMPER End Section	1	Cleaned and folded	4 Persons
Pigtail	1	Cleaned and coiled	1 Person
TEMPER ISO Modified End Section	1	Cleaned and folded	4 Persons
Wastewater Drain Hose 2" x 20'	1	Cleaned and Coiled	1 person
TEMPER Frame Components	1	Cleaned and folded	4 Persons
100 AMP Cable, 50 ft	2	Cleaned, Coiled, Caps installed	2 Persons each cable
Pigtail	1	Cleaned and Coiled	1 Person
Table, folding	4	Folded and Tied	1 Person each table
Freshwater Tank, 3,000 Gallon	1	Drained clean and folded	4 Persons
Ground Rod	1	Cleaned, with wire attached	1 Person
Fluorescent Light Set	1	In Protective Case	2 Persons
TEMPER, 8-ft Window Section	1	Cleaned and folded	4 Persons
Freshwater Supply Hose 2" x 20'	1	Drained and coiled	1 Person
Footlocker, containing:	1		1 Person
Garden Hose	1	Drained, coiled, ends connected	
Technical Manual	1	In plastic bag	
120 VAC Power Cord	1	Cleaned and coiled	
Adjustable Wrench	1	Cleaned	
Flash Light	1	Cleaned and Operating	
Washer/Dryer Repair Parts	1	Original Pack	
Tape	1	Duct Tape	
Screwdriver, Close Quarter	1	Cleaned	
Tie Down Straps	5	Install as Pack Progresses	1 Person



**WARNING**

The CSSL container weighs approximately 10,000 pounds when packed. Lift and move the container only with material handling equipment of at least 10,000 pounds capacity. If forklift is used, lift at outside pockets. Observe all safety precautions. Never stand under a CSSL container when it is being lifted.

- Using a 10,000 lbs forklift (minimum) or other lifting device, lift and move the CSSL onto a conveyance for shipment.

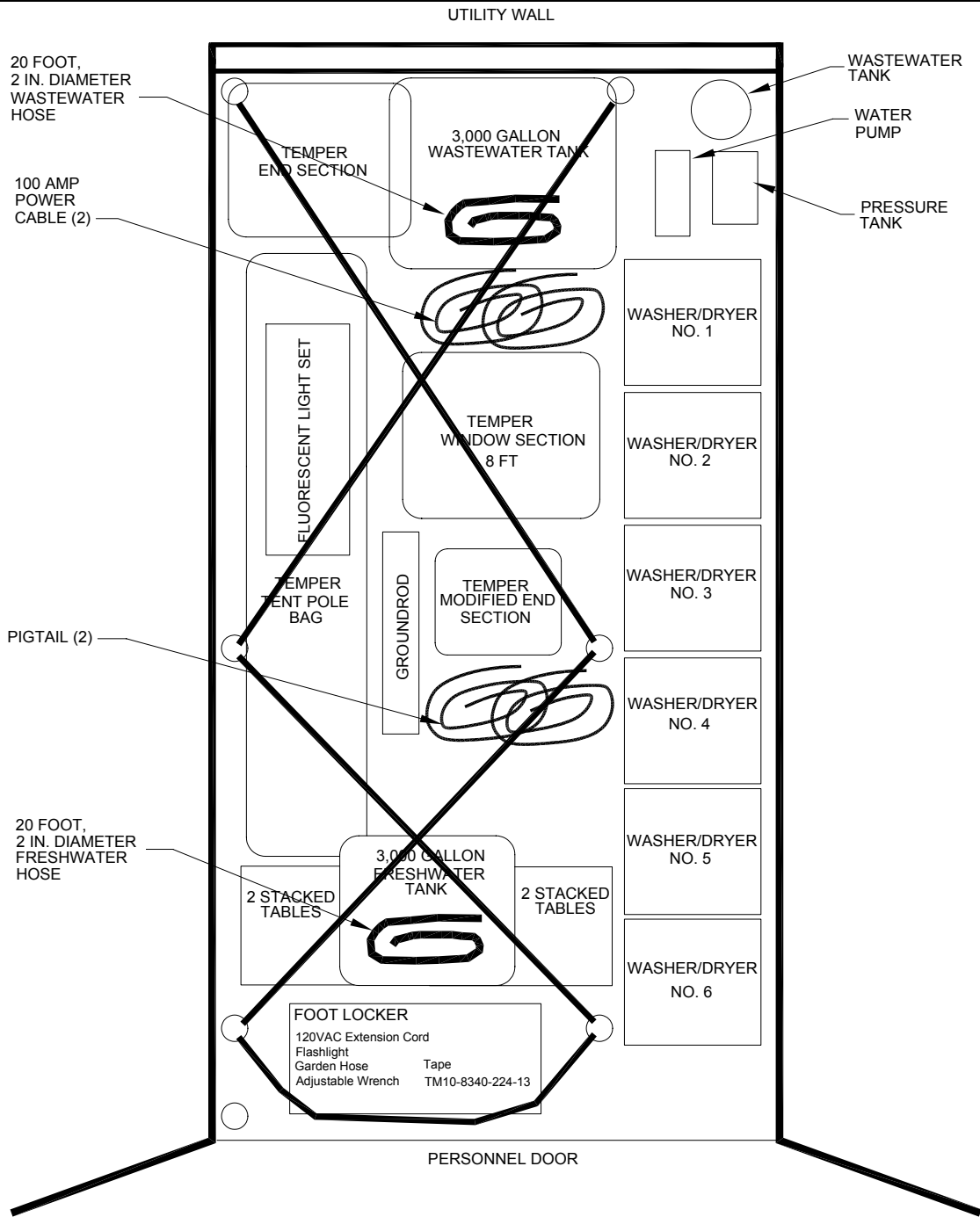

CSSL Packing Plan.

END OF WORK PACKAGE

**CONTAINERIZED SELF SERVICE LAUNDRY (CSSL)  
NSN 3510-10-485-0457  
OPERATION UNDER UNUSUAL CONDITIONS**

**OPERATION UNDER UNUSUAL ENVIRONMENT/WEATHER CONDITIONS.**

**General.** Refer to Operation Under Usual Conditions (WP 0005 00), for specific operating instructions, and use this work package for further instruction if operating the CSSL in unusual conditions. Read all sections that apply to the conditions to which the CSSL will be exposed.

Unusual conditions include severe weather, such as 90 to 100 percent humidity for a week or more; 32 degree Fahrenheit (zero degree centigrade) or below temperatures. 100 degree Fahrenheit (38 degree centigrade) or above temperatures, blowing sand or dust; heavy rain or snow.

**Operation in extreme heat (moist and dry) conditions.** Keep the side double service doors open and operate the fan to ventilate the container.

**Operation in extreme cold conditions.** The CSSL is not designed for use in temperatures below 32<sup>0</sup> F. If temperatures below 32<sup>0</sup> F are expected intermittently for short periods of time, such as overnight, shut the facility down as described below:

**Using Municipal Water:**

1. Shut off the fresh water supply at the source. Disconnect the 2" freshwater hose (1) from the source and the fitting on the freshwater panel (2) on the utility wall of the container. Drain hose, coil it, and set it aside.
2. Connect the garden hose to the hose fitting (3) located at the end of the supply line (behind washer/dryer #6) and open (handle in line with water line) the ball valve (4) to let the system drain.
3. After the supply line has drained, disconnect garden hose. Leave ball valve (4) open (handle in line with water line) Drain hose, coil it, connect the ends together and set it aside.

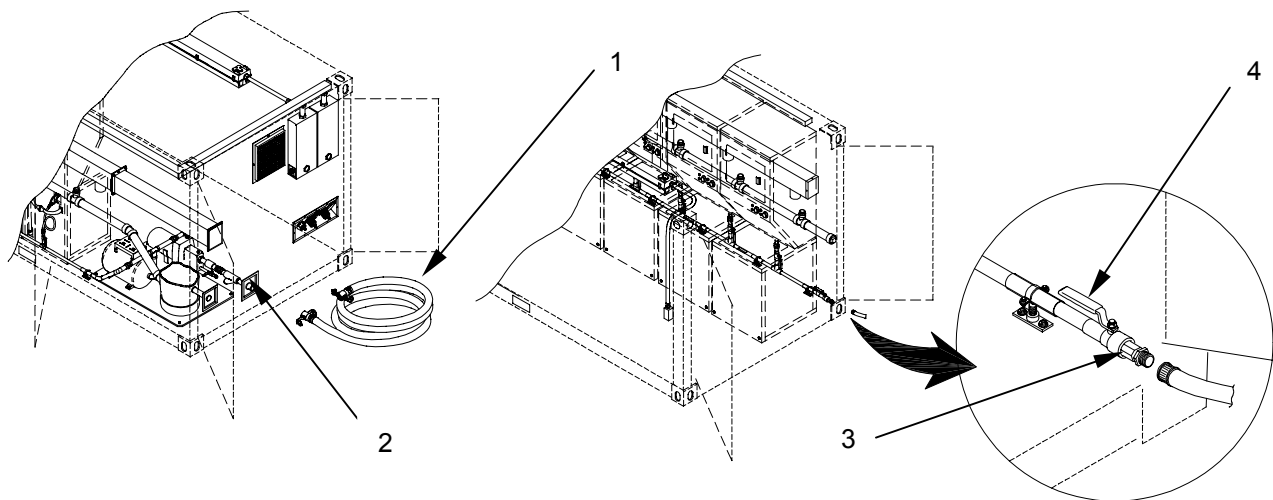

**Using a 3,000 Gallon Freshwater Tank:**

1. Shut off the freshwater pump (1) by setting circuit breaker # 3 in the right side Power Distribution Panel to **OFF**. Disconnect the 2" freshwater hose (2) from the freshwater inlet panel (3) on the utility wall. While holding the end of the hose above the water level in the freshwater tank (4), place the end of the hose (2) into the freshwater tank as shown.
2. Connect garden hose to the hose fitting (6) located at the end of the supply line (behind washer/dryer #6) and open (handle in line with water line) the ball valve (7). Leave the valve open after system has drained. Disconnect garden hose, drain and coil it, connect the ends together and set it aside.
3. Drain the 3,000 Gallon freshwater tank (4) in accordance with TM 10-5430-237-12&P. Remove the 2" freshwater hose (2) from the freshwater tank. Drain the hose, coil it, connect the ends together and set it aside.
4. Place the garden hose inside the CSSL. Coil and place the 2" freshwater hose (2) together with the 3,000 Gallon freshwater tank (4) inside the CSSL.

**WARNING**

Avoid spillage of wastewater. Drain wastewater hoses into an approved disposal facility. Keep wastewater hoses away from freshwater hoses and any freshwater supply in the vicinity. Serious health problems may result from freshwater contamination.

5. After the sump pump (8) has stopped running, shut off the pump (Circuit Breaker #12, right side Power Distribution Panel).

**Using a Municipal Disposal System:**

1. Disconnect the 2" wastewater hose (9) from the wastewater panel (10) on the utility wall, and drain it into the disposal connection.
2. Disconnect the 2" wastewater hose (9) from the wastewater disposal point. Coil the hose and set it aside. Install the dust cap (11) on the panel (10).

**Using a 3,000 Gallon Wastewater Collection Tank:**

1. Disconnect the 2" wastewater hose (9) from the wastewater panel (10) on the utility wall. While holding the end of the hose above the water level in the 3,000 Gallon wastewater tank (12), place the end of the hose into the wastewater tank as shown. Install dust cap (11) on panel (10).
2. Empty the 3,000 Gallon wastewater tank (12) in accordance with TM 10-5430-237-12&P. Remove the 2" wastewater hose (9) from the wastewater tank. Drain the hose, coil it, and set aside.
3. Place the 2" wastewater hose (9) and the 3,000 Gallon wastewater tank (12) inside the CSSL.

4. Clean out the dryer lint traps (13) and dispose of the lint. Clean the CSSL and TEMPER as described in work package 0010 00.

5. Leave the external power cables connected to the CSSL. Turn **OFF** all circuit breakers in the left side power distribution panel (14). Leave circuit breakers 1, 10 and 15, in the right side power distribution panel (15) **ON**. Turn circuit breakers 3, 5, 7, 8, 12, 17, and 20 in the right side Power Distribution Panel **OFF**. Turn the space heater control knob until the heater comes on. Close all window flaps on the TEMPER and slide fasteners around the entry. Close the container side doors (16) and personnel doors. To re-activate the CSSL, follow the procedures in Work Package 0005 00, Prepare TEMPER with Modified End Section for Use.

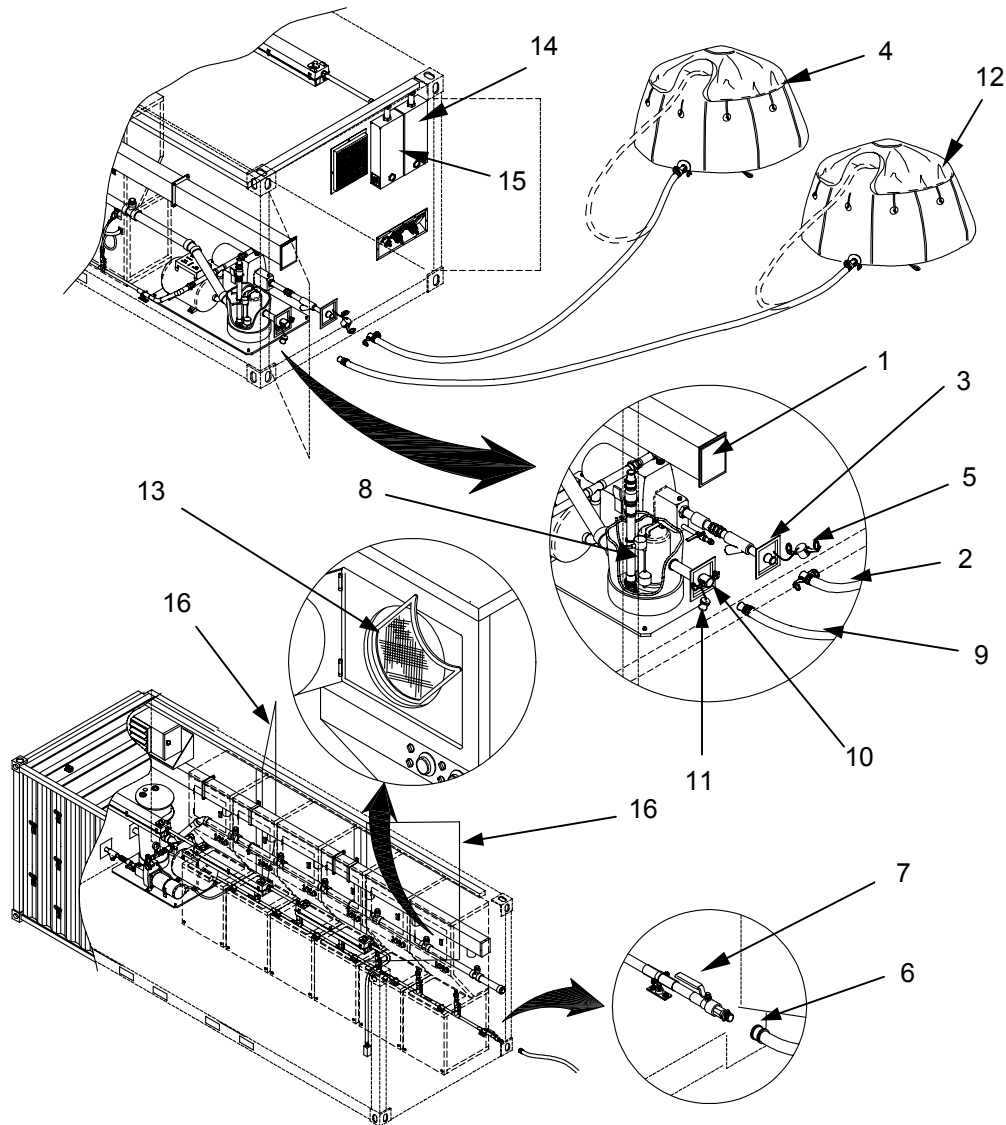

**Operation in snowy or muddy conditions.** Ensure TEMPER and CSSL are placed on firm foundations. Keep the personnel entrance and side double service doors closed to protect the equipment. Also, see operation in extreme cold conditions, above.

**Operation in dusty or sandy conditions.** Clean dryer lint filters more frequently. Keep the side double service doors closed to protect the equipment.

**Operation in rainy and/or humid conditions.** Keep the side double service doors closed to protect the equipment.

**Operation in high altitude conditions.** CSSL should not be operated above 7000 feet (2128 meters)

**Nuclear, Biological, and Chemical (NBC) Alert Condition and Decontamination.** The CSSL is not designed or intended for operations during an NBC event or environment, however, if exposed during it's closed travel configuration, decontaminate with relative ease using the procedures in FM 3-5 for "Operational Decontamination". Whenever alerted to possible NBC attack, commanders utilizing the CSSL should employ, as a minimum, the following contamination avoidance procedures:

1. If time permits, break down the CSSL operations and place it into it's traveling configuration with all components drained and packed inside as described in WP 0005 00-49 "Packing for Return Shipment"
2. If time does not permit complete repacking, then complete the following as quickly as possible.
3. Disconnect and drain the freshwater and wastewater hoses and store them in the container. Cap the container hose connection ports.
4. Turn off generator power, disconnect the electric power cables and cover the connector ends and ports. Store all cables inside the container.
5. Close all CSSL container doors and all window, door and vent flaps on the TEMPER tent.
6. If possible, drain at least the freshwater tank and store it in the container.



## **WARNING**

Do not place a CSSL that has been through an NBC attack back into operation until it has been decontaminated. Serious illness, injury or death to personnel could result.

**Decontamination.** Decontaminate the exterior of a packed CSSL container IAW operational or thorough decon procedures in FM 3-5. Have trained personnel check the interior components using appropriate detection methods and perform further decon as necessary before placing the CSSL into operation. Replace components that cannot be decontaminated. Dispose of the contaminated components IAW the instructions of the trained NBC personnel.

**END OF WORK PACKAGE**



**TM 10-3510-224-13&P**

**CHAPTER 3**  
**OPERATOR TROUBLESHOOTING AND SERVICE PROCEDURES**  
**FOR THE**  
**CONTAINERIZED SELF SERVICE LAUNDRY**  
**(CSSL)**  
**MODEL B**

THIS PAGE INTENTIONALLY LEFT BLANK

---

**CONTAINERIZED SELF SERVICE LAUNDRY (CSSL)  
NSN 3510-01-485-0457  
OPERATOR LUBRICATION AND SERVICE PARTS INFORMATION**

---

**LUBRICATION REQUIREMENTS.**

**NOTE**

Lubrication requirements for CSSL components must be followed in the technical manuals specified below to prolong the serviceable life of these items.

CSSL-unique lubrication requirements are limited to the container and the TEMPER. Refer to TM 55-8115-204-23&P and TM 10-8340-224-13, respectively.

**END OF WORK PACKAGE**

THIS PAGE INTENTIONALLY LEFT BLANK

---

**CONTAINERIZED SELF SERVICE LAUNDRY (CSSL)  
NSN 3510-01-485-0457  
OPERATOR TROUBLESHOOTING PROCEDURES**

---



---

**WARNING**

---

Do not attempt to connect the power source to the CSSL Power Entry Panel. Only MOS 51R, 52C, 52D, or 52G qualified personnel can perform this procedure. Serious injury and death can result from electrical shock.

The Malfunction Symptom Index lists common malfunctions that may occur during CSSL inspection and operation.

Find a malfunction the CSSL is having in the index, and go to the troubleshooting procedure provided in this work package.

This chart cannot list all the malfunctions that may occur, or all tests or all inspections needed to find the fault, nor all actions required to correct the fault. If your malfunction is not listed, or is not correctable in this troubleshooting index, notify your supervisor or Unit Maintenance.

**DO NOT START A TASK UNTIL:**

- You understand the task.
- You understand what you are to do.
- You understand what is needed to do the work.
- You have the things you need.

**MALFUNCTION SYMPTOM INDEX.**

<b>Malfunction or Symptom</b>	<b>Refer to Troubleshooting Procedure</b>
Electrical Appliances Inoperative	1
Water Leak	2

Procedure 1: Loss of Power

INITIAL SETUP:

**Equipment Condition:**  
CSSL set-up, but not in operation

**Materials/Parts**  
None

**Maintenance Level**  
Operator

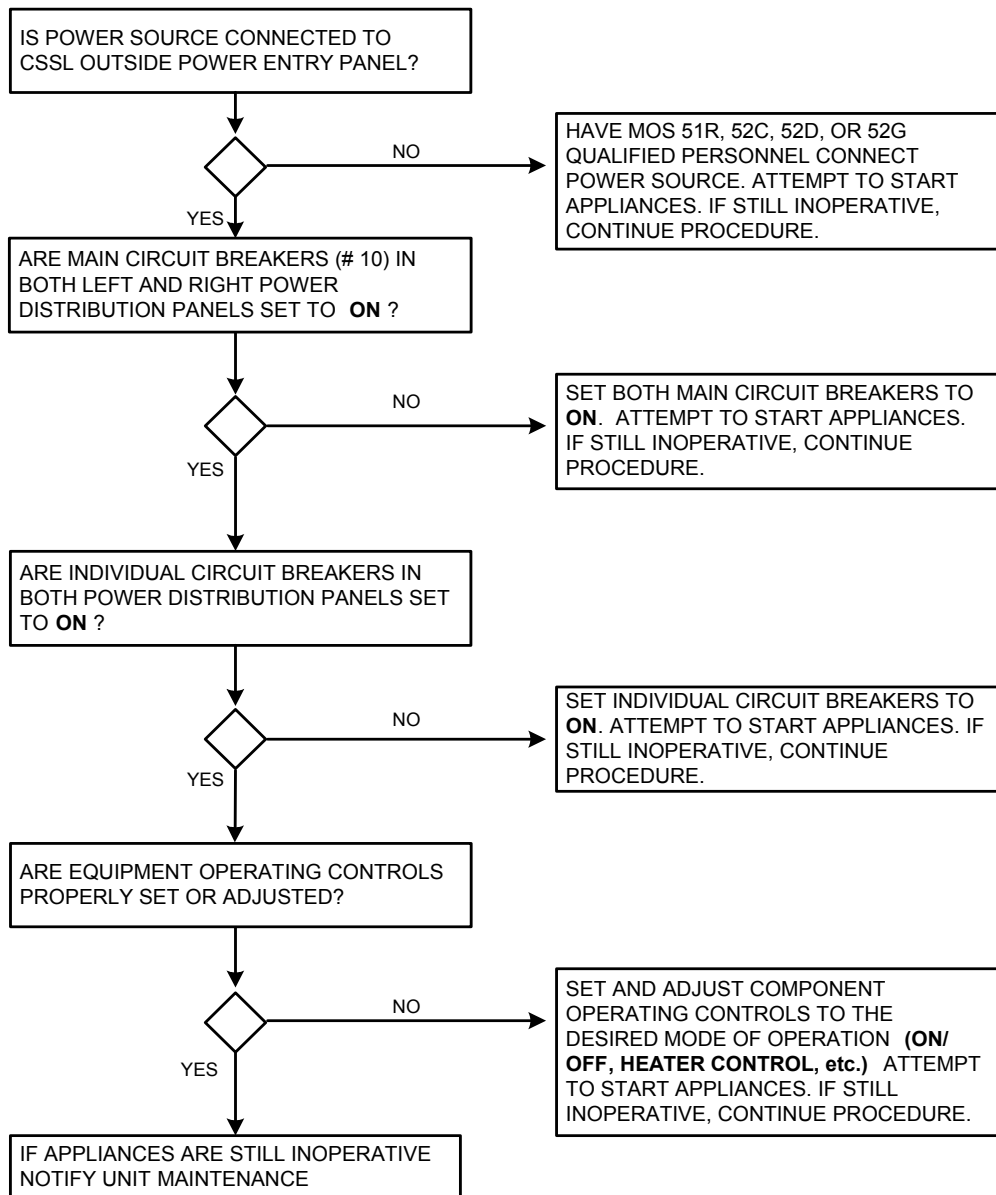

**Procedure 2: Water Leak**

**INITIAL SETUP:**

**Equipment Condition**

CSSL set-up, but not in operation

**Materials/Parts**

None

**Maintenance Level**

Operator

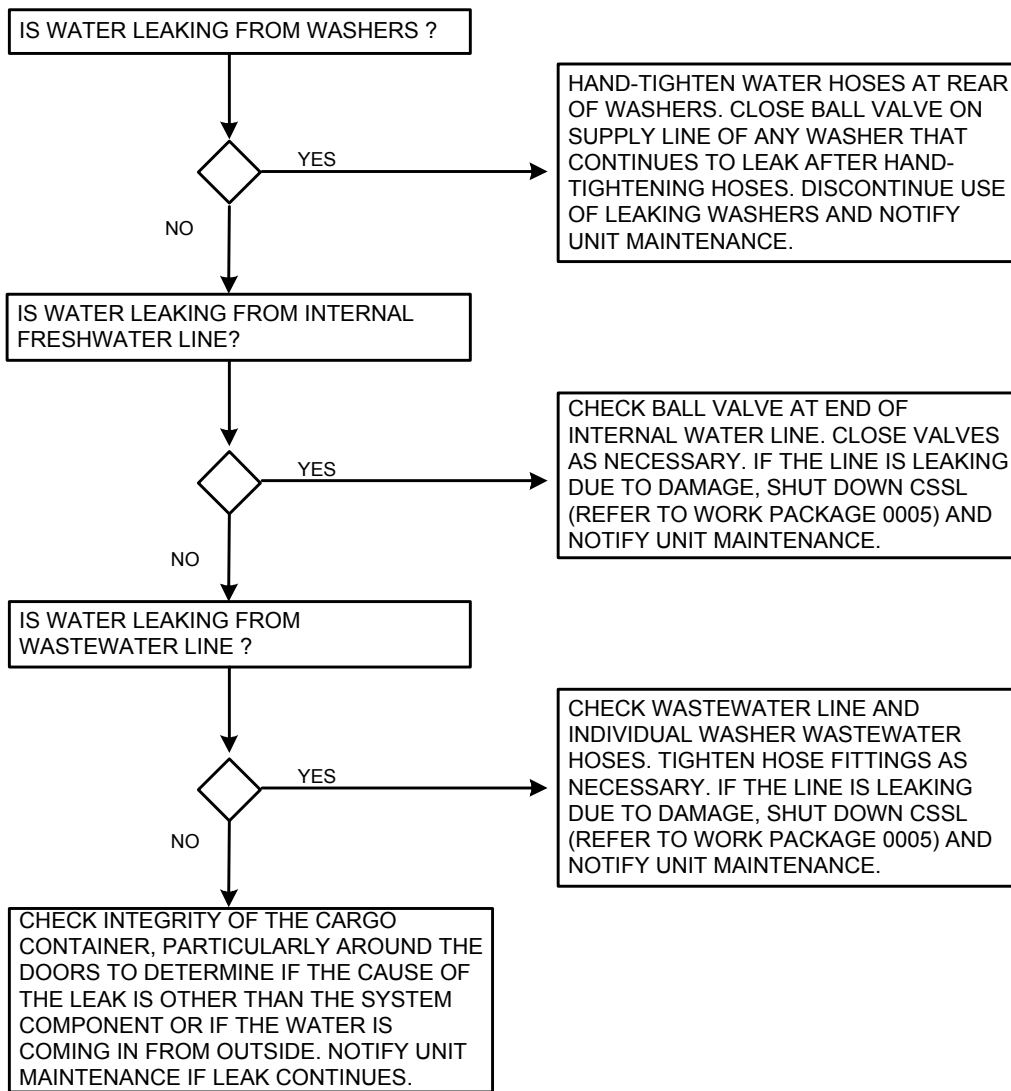

**END OF WORK PACKAGE**

THIS PAGE INTENTIONALLY LEFT BLANK



**TM 10-3510-224-13&P**

**CHAPTER 4  
OPERATOR MAINTENANCE INSTRUCTIONS  
FOR THE  
CONTAINERIZED SELF SERVICE LAUNDRY  
(CSSL)  
MODEL B**

THIS PAGE INTENTIONALLY LEFT BLANK

**Introduction, PMCS Procedures**

**INITIAL SETUP:**

**Equipment Condition**

CSSL set-up, but not in operation

**Materials/Parts**

Rags (WP 0070, Table 1, Item 1)

Light Fluorescent Gen Purp. (WP 0070, Table1, Item 2)

**Maintenance Level**

Operator/Unit

**Tools and Special Tools**

None

**Introduction.** Preventive Maintenance Checks and Services (PMCS) keeps the CSSL and its associated equipment in good operating condition. The checks aid in finding, correcting, or reporting problems. Operator personnel are to do the PMCS jobs as shown in the PMCS table. Pay attention to WARNING and CAUTION statements. A WARNING means someone could be hurt. A CAUTION means equipment could be damaged.

Do PMCS procedures each day the CSSL is in operation, using the PMCS table in this work package. There are different intervals to perform PMCS procedures: before, during and after using the equipment, as well as weekly and monthly. Look at the table carefully to identify the required PMCS interval.

If you find something wrong when performing PMCS, fix the problem using troubleshooting and/or maintenance procedures.

The far right-hand column of the PMCS table lists conditions that make the CSSL not fully mission capable. Write down the problem that cannot be repaired on a DA Form 2404 for unit maintenance. For further information on how to use this form, see DA PAM 738-750.

If tools that are required to perform PMCS are not listed in the procedures, notify your supervisor.

**Inspection.** Look for signs of trouble. Use your senses to feel, smell, hear, or see many problems that may exist. Inspect to see if items are in good condition. Are components correctly installed and secured? Is any damage to the frame or components visible? Correct any faults or notify Unit Maintenance.

**Associated Components.** Perform PMCS on the TEMPER, freshwater pump, 3,000 gallon fabric tanks, modified cargo container, 100 AMP power supply cables and pigtailed in accordance with the publications specified in work package 0040 00, References.



---

**WARNING**

---

CSSL electrical connections can be made only by MOS 51R, 52C, 52D, 52G or qualified civilian personnel. If ungrounded power is used, the CSSL cargo container must be electrically grounded. Failure to ground the CSSL may result in serious injury or death to personnel from electrical shock.

There are some common items to check on the CSSL and associated equipment. These include the following:

- Proper operation and condition of the washer/dryers
- Condition of the water supply, wastewater drain hoses and freshwater drain hoses.
- Proper operation of interior lights, space heater and vent fan
- Condition of 3,000 gallon capacity freshwater and wastewater fabric tanks (if used)
- Condition of the power supply cable
- Condition and proper connection of ground rod (if used)

**Lubrication Service Intervals.**

Lubricate the door hinge and latch assembly of the general cargo container in accordance with TM 55-8115-204-23&P. Lubricate the TEMPER in accordance with TM 10-8340-224-13.

**Service.**

Proper service of the CSSL and components is an integral part of maintenance. Regular cleaning prevents possible problems in the future, so make it a habit to clean the CSSL and its components whenever necessary.

Frequently wipe down the Washer/Dryers with a rag and check the lint traps daily.

Sweep the interior of the cargo container on a daily basis and keep it clean of trash on a regular schedule.

**Before Operation PMCS Checks and Services.**

**INITIAL SETUP:**

**Equipment Condition**

CSSL set-up, water and power connected

**Materials/Parts**

Rags (WP 0070, Table 1, Item 1)

Fluorescent light bulbs (WP 0070, Table 1, Item 2)

**Maintenance Level**

Operator/Unit

**Tools and Special Tools**

None

**Table 1. Preventive Maintenance Checks and Services for the CSSL.**

Item No.	Interval	Item to be checked or serviced	Procedure	Equipment not ready/available if:
1	Before	Washers/Dryers	Open washers (1) to determine if they contain any water that has not drained properly, clothes, or other items. Drain water by activating washer. (If problem persists, notify Unit Maintenance. Check the condition and proper attachment of the water supply (2) and wastewater drain (3) hoses. Check for leaks. Check and, if needed, clean out dryer lint traps (4). Check for secure attachment and general condition of dryer ducts (5).	Washers contain water of previous wash cycle, clothes or other items. Dryers that contain clothes or other items. Dryer lint traps are clogged. Dryer exhaust hoses loose, clogged or damaged. Water supply or drain hoses loose, damaged or missing. Washers leak.
2	Before	Water Service Panels	Check the freshwater (6) and wastewater (7) panels for physical damage, leaks and corrosion.	Panels or QD fittings are damaged. Hoses are improperly connected and leaking. Excessive corrosion.
3	Before	Interior Lights	Activate interior lights (8) and check if they operate. Replace any burned out light bulbs (9) (Refer to WP 0015 00). Refer inoperative light switch or inoperative light fixtures to Unit Maintenance.	Light fixtures inoperative, light switch, and excessive number of light bulbs burned out.
4	Before	Vent Fan	Activate Vent fan (10) by switching to EXHAUST for 30 seconds. Switch back to OFF. Switch to INTAKE for 30 seconds. Switch back to OFF. Refer an inoperative vent fan to Unit Maintenance	Vent fan inoperative. Noisy operation.
5	Before	Space Heater	Activate space heater (11) and check for proper operation. Check for functioning of the heater control (12). Check for any damage to the unit.	Heater control inoperative, damage to space heater.
6	Before	Power Entry Panel	Check for physical damage to panel (13) connectors and cables (14). Ensure cables are properly connected. (Refer to Work Package 0005 00).	Damaged panel or connectors. Improper or loose electrical connections.

**Table 1. Preventive Maintenance Checks and Services for the CSSL-Continued.**

Item No.	Interval	Item to be checked or serviced	Procedure	Equipment not ready/available if:
7	Before	CSSL Modified End Section	<p>Check Modified End Section (15) for rips, tears, missing hardware or improper installation.</p> <div style="text-align: center;">  <p><b>WARNING</b></p> </div> <p>Do not touch damaged circuit breakers. Notify Direct Support Maintenance.</p>	Ripped or torn fabric. End wall not properly installed.
8	Before	Circuit Breakers	Open circuit breaker panel (17) and examine circuit breakers. Note any damage to the breakers or to the panel. If no damage is noted, activate the breakers to determine their proper operation.	Damaged or non-functioning Circuit breakers
9	Before	Exterior GFCI	With the main circuit breaker (#10) in the left side power distribution panel set to <b>ON</b> , set circuit breaker #17 to <b>ON</b> and test the GFCI receptacle on the power entry panel in the utility wall (18) by pushing the TEST button. Observe the indicator light. If the indicator light does not activate, push the RESET button. Repeat the test. If the receptacle does not work, refer to Unit Maintenance.	Receptacle does not work, is damaged or is missing hardware.
10	During	Washers/Dryers	Open washers (1) to determine if the water has not drained properly, any clothes or other items. Drain water by activating the washer. (if water remains, notify Unit Maintenance). Check the condition and proper attachment of the freshwater (2) and wastewater (3) hoses. Check for leaks. Check and, clean out the dryer lint traps (4). Check for secure attachment and general condition of the dryer exhaust ducts (5).	Washers leak, drain line clogged, filters clogged, water lines loose damaged corroded or missing.
12	During	Interior Lights	If light (8) fails during operation, replace the light bulb (refer to WP 00015 00). If light fails to operate, notify Unit Maintenance.	Light fixtures or light switch inoperative. Excessive number of light bulbs burned out.

**Table 1. Preventive Maintenance Checks and Services for the CSSL-Continued.**

Item No.	Interval	Item to be checked or serviced	Procedure	Equipment not ready/available if:
13	During	Vent Fan	If vent fan <b>(10)</b> fails during operation, cycle the switch. If no response, notify Unit Maintenance.	Vent Fan inoperative or noisy.
14	During	Space Heater	If heater <b>(11)</b> fails during operation, rotate the heater control knob <b>(12)</b> fully in both directions. If no response, notify Unit Maintenance.	Space Heater inoperative.
15	During	Power Entry Connectors	If power fails during operation, check for physical damage to the power entry panel <b>(17)</b> . Ensure that the cables are properly connected (refer to WP 0005 00). If connections appear secure and there is still no power, notify Unit Maintenance.	Damaged power entry panel or connectors. Improper connections.
16	During	CSSL Modified End Section	<p>In adverse weather conditions check the securing straps <b>(16)</b>. Check for torn or otherwise damaged fabric.</p> <div style="text-align: center;">  <p><b>WARNING</b></p> <p>Do not touch damaged circuit breakers. Notify Direct Support Maintenance.</p> </div>	Torn fabric, loose straps, missing or damaged hardware.
17	During	Circuit Breakers	If a circuit breaker trips during operation, open the circuit breaker panel <b>(17)</b> and examine the circuit breakers. Note any damage to the breakers and the panel. If no damage is noted, activate the breakers to determine if they function properly. If the breaker trips again, notify Unit Maintenance.	Damaged or non-functioning circuit breakers.
18	During	Exterior GFCI Receptacle	If power from the GFCI receptacle fails, set the main circuit breaker <b>(#10)</b> in the left side power distribution panel, to <b>ON</b> . Set circuit breaker <b>#17</b> to <b>ON</b> and test the GFCI receptacle on the power entry panel on the utility wall <b>(18)</b> by pushing the TEST button. If the indicator light does not activate, push the RESET button. Repeat the test. If the receptacle does not work, notify Unit Maintenance.	Damaged or non-functioning exterior GFCI receptacle.

Table 1. Preventive Maintenance Checks and Services for the CSSL-Continued.

Item No.	Interval	Item to be checked or serviced	Procedure	Equipment not ready/available if:
19	After	Washers/Dryers	Open each washer <b>(1)</b> to determine if they contain any water that has not drained properly, or any clothing or other items. If necessary, drain any water by activating the washer. Check, and if needed, clean out the dryer lint traps <b>(4)</b> .	Not ready if washers contain water or items from previous use, If hoses are corroded, clogged, leaking or otherwise damaged.
20	After	Water Service Panel	Check the freshwater panel <b>(6)</b> and the wastewater panel <b>(7)</b> for damage, leaks and corrosion.	Not ready if panel, hoses or fittings are damaged or corroded.
21	After	Interior Lights	Replace any burned out light bulb <b>(9)</b> as required. Notify Unit Maintenance of a defective or questionable light switch.	Light fixtures or light switch inoperative.
22	After	Vent Fan	Ensure Vent Fan <b>(10)</b> is clear and free of debris. Notify Unit Maintenance of defective Vent Fan.	Vent Fan inoperative or noisy.
23	After	Space Heater	If Space Heater <b>(11)</b> is inoperative, rotate the control knob <b>(12)</b> fully in both directions. If heater does not respond, notify Unit Maintenance.	Space Heater damaged or inoperative.
24	After	Power Entry Panel	Ensure that connectors are secure and that no damage has occurred to the panel <b>(13)</b> . Notify Unit Maintenance of any damage to the panel or to the connectors.	Damaged panel or connectors. Improper or loose connections. Missing or damaged hardware.
25	After	TEMPER Modified Endwall Boot	Ensure that cinch straps and tie downs are secure. Check for torn or damaged fabric. Ensure that hook and pile closures are secure.	Torn fabric, loose, damaged or missing straps.
26	After	Circuit Breakers	If circuit breaker trips, reset the circuit breaker. If the problem persists, notify Unit Maintenance.	Circuit breakers damaged or non-functioning.



**Table 1. Preventive Maintenance Checks and Services for the CSSL-Continued.**

Item No.	Interval	Item to be checked or serviced	Procedure	Equipment not ready/available if:
27	After	Exterior GFCI Receptacle	Check that the connection is secure. Check for missing or damaged hardware. Notify Unit Maintenance of any damage to the GFCI receptacle.	Damaged receptacle, loose connector, missing hardware.
28	Weekly	Washers/Dryers	Open each washer (1) to determine if they contain water that has not drained properly, or any clothing or other items. If necessary, drain any water by activating the washer. Check, and if needed, clean out the dryer lint traps (4). Check the attachment and general condition of the dryer exhaust ducts (5). Verify that the washer mounting is secure.	Not ready if Washer/Dryer mounting is not secure. Connections are loose or damaged.
29	Weekly	Water Service Panel	Check the freshwater panel (6) and the wastewater panel (7) for damage, leaks and corrosion.	Not ready if panel, hoses or fittings are damaged or corroded.
30	Weekly	Interior Lights	Check for loose, damaged or missing covers or mounting clips. Check for non-functioning lights or light switch. Notify Unit Maintenance of defective light switch.	Lights or light switch inoperative.
33	Weekly	Power Entry Panel	Ensure connectors are secure and that no damage has occurred to the panel (13). Notify Unit Maintenance of any damage to the panel or to the connectors.	Damaged panel or connectors. Improper or loose connections. Missing or damaged hardware.
34	Weekly	TEMPER Modified Endwall Boot	Check for security and condition of straps and hook and pile closures. Check for torn fabric or frayed cinch straps.	Torn fabric, loose damaged or missing straps.
35	Weekly	Circuit Breakers	Check for tripped circuit breaker(s). Reset the tripped circuit breaker(s). If the Breaker trips again notify Unit Maintenance. Check for security of connections. Check for damaged or missing hardware. Push the TEST button. Observe the indicator light. If the indicator light does not activate, push the RESET button. Repeat the test. If the receptacle does not work, replace it as described in WP 0029 00.	Circuit Breaker(s) inoperative.

**Table 1. Preventive Maintenance Checks and Services for the CSSL-Continued.**

Item No.	Interval	Item to be checked or serviced	Procedure	Equipment not ready/available if:
36	Weekly	Exterior GFCI Receptacle	Check for security of connections. Check for damaged or missing hardware. Push the TEST button. Observe the light indicator. If the indicator does not activate, push the RESET button. Repeat the test. If the receptacle does not work, notify Unit Maintenance.	GFCI outlet damaged or inoperative. Missing hardware.

Monthly PMCS procedures would be the same procedures as for weekly PMCS procedures, with the addition of placing more emphasis on corrosion inspection, condition of water connections and mounting security of the Washer/Dryers.

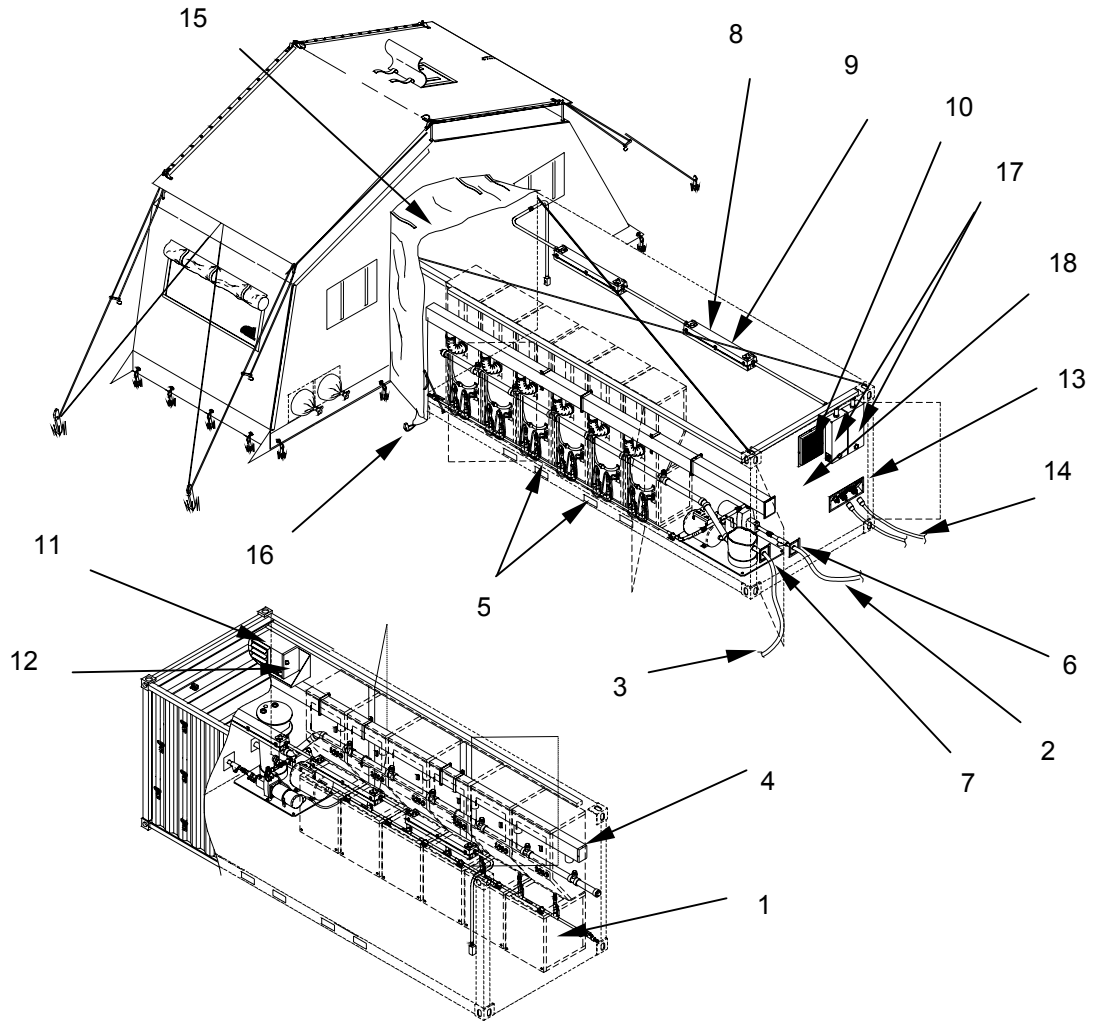

END OF WORK PACKAGE

THIS PAGE INTENTIONALLY LEFT BLANK

---

**OPERATOR MAINTENANCE  
CONTAINERIZED SELF SERVICE LAUNDRY (CSSL)  
NSN 3510-01-485-0457  
INSPECT, SERVICE**

---

**INITIAL SETUP:****Equipment Condition**

CSSL set-up, but not in operation

**Materials/Parts**

Rags, Broom, Mop

**Maintenance Level**

Operator/Unit

**Personnel Required****One****Tools and Special Tools**

None

**INTRODUCTION**

This section contains Operator Maintenance for the CSSL as authorized by the Maintenance Allocation Chart (MAC) in WP 0042 00 of this manual. Only one person is needed to perform these maintenance procedures, unless otherwise indicated. Read all **WARNINGS, CAUTIONS, and NOTES** carefully before attempting these procedures, including the warnings at the front of this manual.

---

**NOTE**

---

Follow the appropriate CSSL component maintenance programs using the appropriate technical manuals. To prolong the serviceable life of this equipment adhere to all maintenance procedures.

**INSPECT**

1. Refer to the appropriate component technical manuals identified in Work Package 0002 00, Location and Description of Major Components, and Work Package 0041 00, References, for specific maintenance instructions pertaining to the Cargo Container and 3,000 gallon tanks (if used). Maintenance instructions covered in this section are CSSL unique.
2. Refer to Table I of Work Package 0009 00, Preventive Maintenance Checks and Services.

**SERVICE**

---

**CAUTION**

---

Do not use any tools to tighten the washer water hoses. Hand-tighten these hoses if necessary. Over tightening the hoses will cause water leaks.

1. Wipe external surfaces of washers/dryers with a rag as necessary to keep the equipment clean. Sweep interior of CSSL frequently and mop up any standing water.
2. Remove debris and trash from the CSSL and TEMPER interior regularly.

**END OF WORK PACKAGE**

**TM 10-3510-224-13&P**

**CHAPTER 5  
UNIT MAINTENANCE INSTRUCTIONS  
FOR THE  
CONTAINERIZED SELF SERVICE LAUNDRY  
(CSSL)  
MODEL B**

THIS PAGE INTENTIONALLY LEFT BLANK



---

**CONTAINERIZED SELF SERVICE LAUNDRY (CSSL)**  
**NSN 3510-01-485-0457**  
**SERVICE UPON RECEIPT**

---

**General.**

To ensure proper functioning of the equipment, perform all tasks prescribed in this work package.

The CSSL is shipped via truck and contains the following components:

One TEMPER, 8 ft Window Section	One Grounding Rod
One TEMPER ISO Modified End Section	One Garden Hose
One TEMPER End Section	One 3,000 Gallon Wastewater Tank
One Freshwater Hose	One 3,000 Gallon Freshwater Tank
One Wastewater Hose	Two Pigtails
Two 100 AMP, 50 ft Power Cables	One TEMPER Frame Section
One Footlocker	



**WARNING**

The Containerized Self Service Laundry is shipped with an anti-freeze solution pumped into the freshwater lines. The anti-freeze solution is non-toxic, but is unsuitable for drinking or washing. **DO NOT OPERATE THE CSSL until the freshwater lines are flushed.**

Once the CSSL is functional, flush the freshwater lines by operating each washer for two complete cycles.



**WARNING**

The laundry components are heavy. To avoid injuries, four persons are required to unload, move and position the components.

**Required tasks upon Receipt of the CSSL.**

**Unpacking.** Open the general cargo container personnel door marked **OPEN FIRST** and remove the components stored inside.

**Packing list verification.** Check the components removed against the packing list to see if the shipment is complete. Report all discrepancies in accordance with DA Pam 738-75.

**Inspection.** Inspect the components and the equipment installed in the general cargo container for damage incurred during shipment. If the equipment is damaged report the damage on SF 364, Report of Discrepancy. In addition, a for Unit Maintenance technician should inspect the equipment, using the PMCS inspection procedures in Work Package 0009 00.

**Verification of equipment modifications.** Verify that the equipment meets all specifications. Notify your supervisor or Unit Maintenance personnel if any modifications were made.

**Pre-operation services.** Service any damaged equipment, if necessary, using Unit Maintenance procedures in this chapter to restore equipment to operable condition. Before operation, check that the washers/dryers and the cargo container are free of packing materials and trash. Service the CSSL prior to operation in accordance with work package 0009 00, Table 1, Preventive Maintenance Checks and Services for the CSSL.

**CSSL Components.** Prepare separate CSSL components for operation as described using work package 0002 00, Location and Description of Major Components, and work package 0041 00, References.

**END OF WORK PACKAGE**

**CONTAINERIZED SELF SERVICE LAUNDRY (CSSL)  
NSN 351-01-485-0457  
UNIT TROUBLESHOOTING PROCEDURES**



**WARNING**

Only MOS 51R, 52C, 52D, 52G, or qualified civilian personnel should connect the power source to the CSSL Power Entry Panel. Serious injury and death can result from electrical shock.

The Malfunction Index lists common malfunctions that may occur during laundry inspection and operation. Find the malfunction the CSSL is having in the index, and go to the indicated troubleshooting paragraph in the following pages.

These charts cannot list all malfunctions that may occur, or all tests and inspections needed to find the fault. If your malfunction is not listed in a chart or is not correctable through this troubleshooting index, notify your supervisor or unit maintenance.

**DO NOT START A TASK UNTIL:**

- You understand the task
- You understand what you are to do
- You understand what is needed to do the work
- You have the things you need

**MALFUNCTION SYMPTOM INDEX.**

<b>Malfunction or Symptom</b>	<b>Refer to Troubleshooting Procedure</b>
Loss of Power	1
Water Leak(s)	2
No Water Pressure	3

**Procedure 1: Loss of Power**

**INITIAL SETUP:**

**Equipment Condition**

CSSL set-up, but not in operation

**Materials/Parts**

None

**Maintenance Level**

Unit

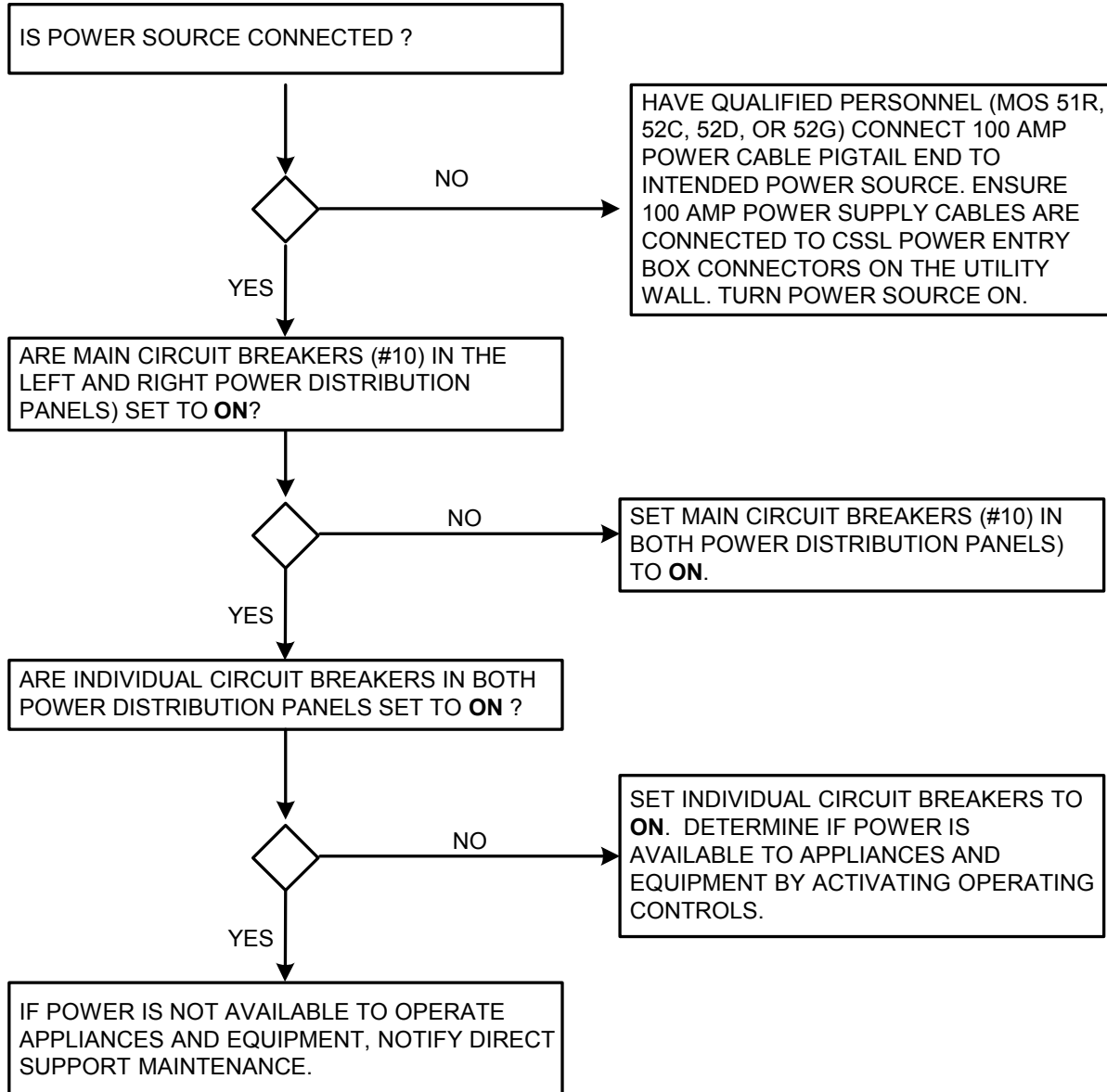

**Procedure 2: Water Leaks**

**INITIAL SETUP:**

**Equipment Condition**  
CSSL set-up, but not in operation

**Materials/Parts**  
None

**Maintenance Level**  
Unit

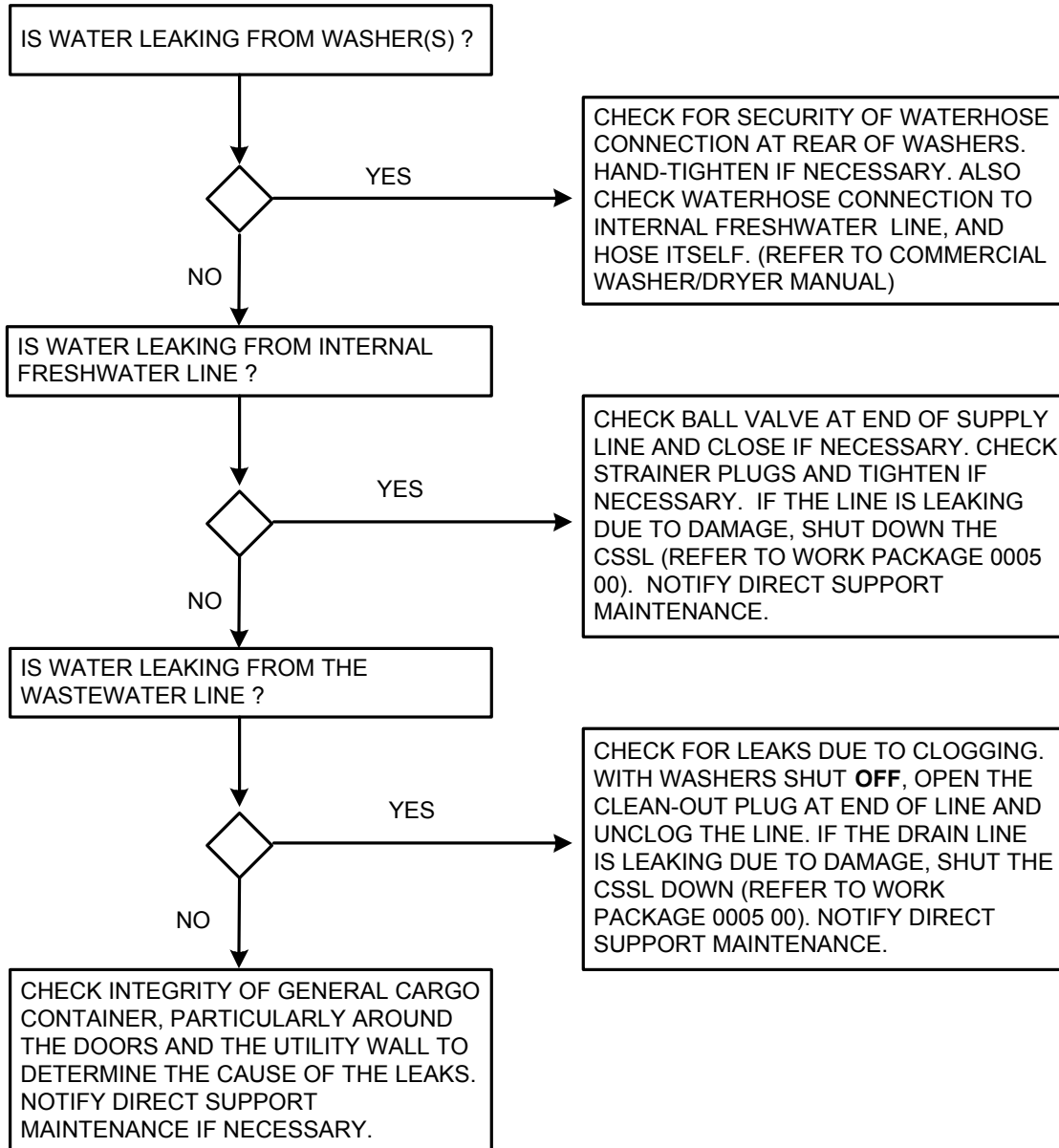

**Procedure 3: No Water Pressure**

**INITIAL SETUP:**

**Equipment Condition**

CSSL set-up, but not in operation

**Materials/Parts**

None

**Maintenance Level**

Unit

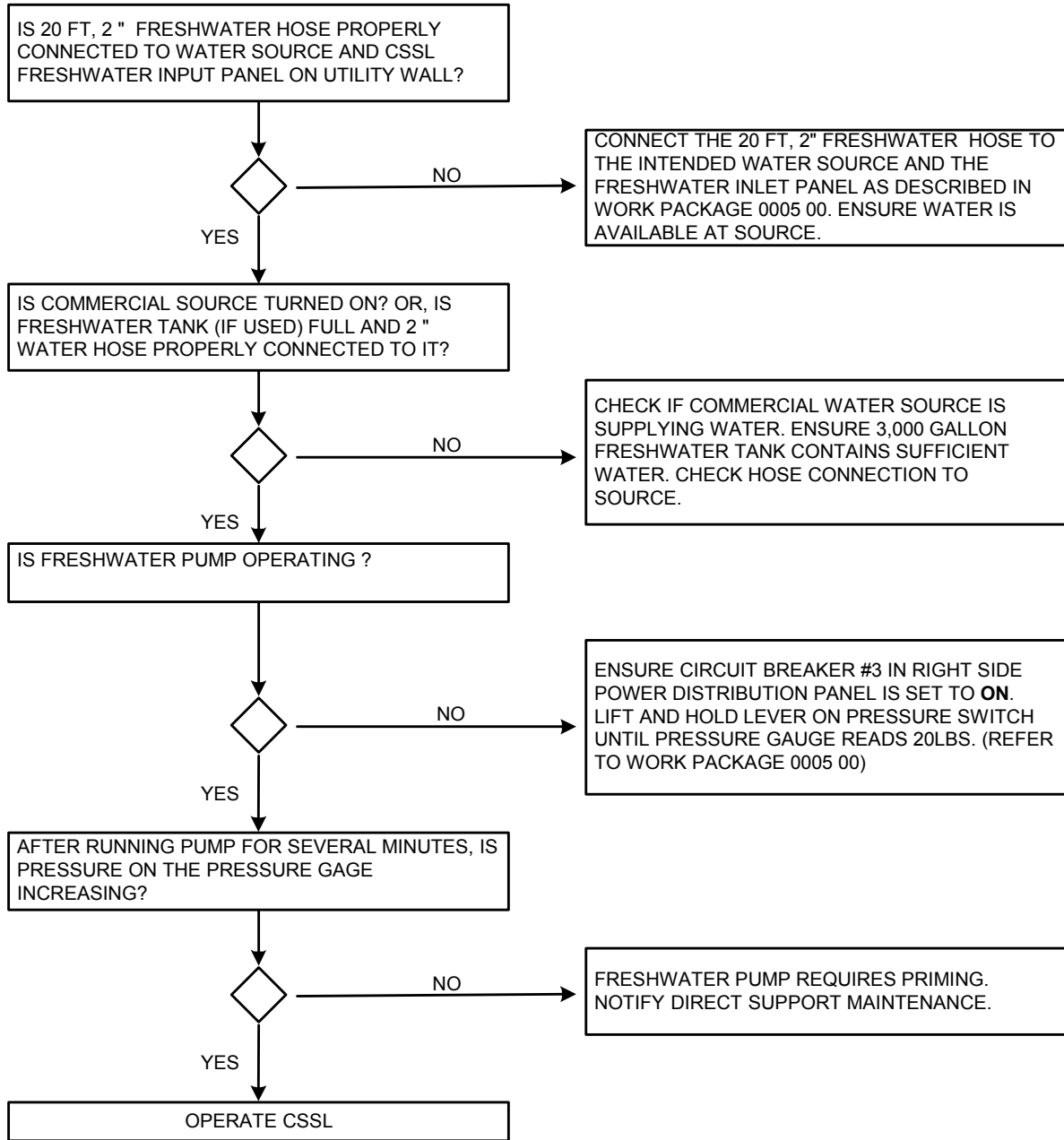

**END OF WORK PACKAGE**

**UNIT MAINTENANCE**  
**CONTAINERIZED SELF SERVICE LAUNDRY (CSSL)**  
**NSN 3510-01-485-0457**  
**POWER ENTRY CONNECTORS**  
**INSPECT**

**INITIAL SETUP:****Equipment Condition**

CSSL set-up, Circuit Breaker #10 in both left and right side Power Distribution Panels turned OFF.

**Materials/Parts**

None

**Tools and Special Tools**

None

**Personnel Required**

One



**WARNING**

This equipment operates at high voltages. Use extreme caution. Turn OFF power supply and disconnect all power cables from the power entry panel. Touching a live wire can cause serious injury or death.

**INSPECT**

1. Inspect the power input plugs **(1)** and **(2)** for damage.
2. Check for bent connector pins **(3)**, corrosion, and stripped or otherwise damaged threads **(4)**.
3. Check for the presence and serviceability of the dust cover **(5)**.
4. Check the pan head screws **(6)** securing the plugs to the panel and tighten if necessary.
5. Check the 110 VAC GFCI receptacle **(7)**, the 20 AMP twist-lock receptacle **(8)**, and the 60 AMP Class L connector **(9)** for corrosion, clogged pinholes, missing covers and loose or missing hardware. Have any unserviceable plug or receptacle replaced through direct support maintenance.
6. Check ground terminal **(10)** for serviceability.

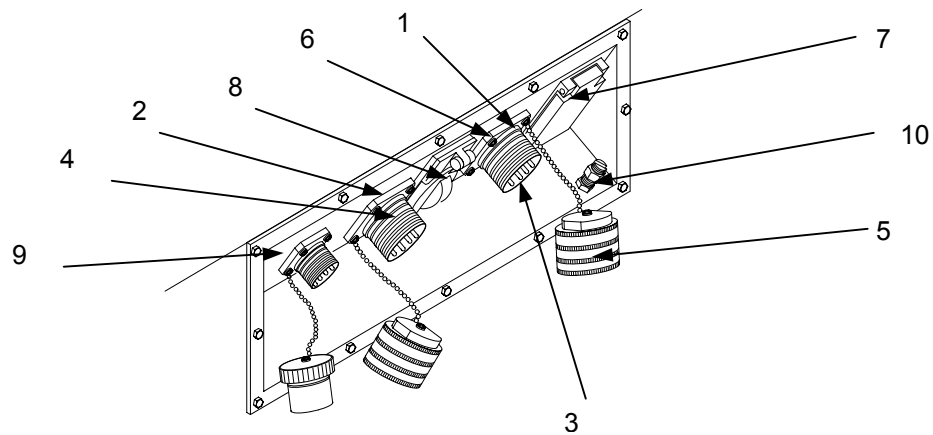

**END OF WORK PACKAGE**

THIS PAGE INTENTIONALLY LEFT BLANK



---

**UNIT MAINTENANCE  
CONTAINERIZED SELF SERVICE LAUNDRY (CSSL)  
NSN 3510-01-485-0457  
POWER DISTRIBUTION PANEL  
INSPECT**

---

**INITIAL SETUP:****Equipment Condition**

CSSL set-up, but not in operation, Power Supply turned OFF, and disconnect all cables from the Power Entry Panel

**Material/Parts**

None

**Tools and Special Tools**

None

**Personnel Required**

One

---



---

**WARNING**

---

This equipment operates at high voltages. Use extreme caution. Touching a live wire can cause serious injury or death.

**INSPECT.**

1. Inspect the left side **(1)** and right side **(2)** power distribution panels for external damage to the housing.
2. Open both panels and check for damage to the circuit breakers **(3)** and panels **(4)**.
3. Switch each breaker to check its functioning. Check for corrosion and missing or loose mounting hardware **(5)**.
4. Tighten loose hardware as necessary.
5. Check for visible damage to the fan switch **(6)**.
6. Check for legibility of warning and identification labels **(7)**. Refer a damaged power distribution panel to direct support maintenance.

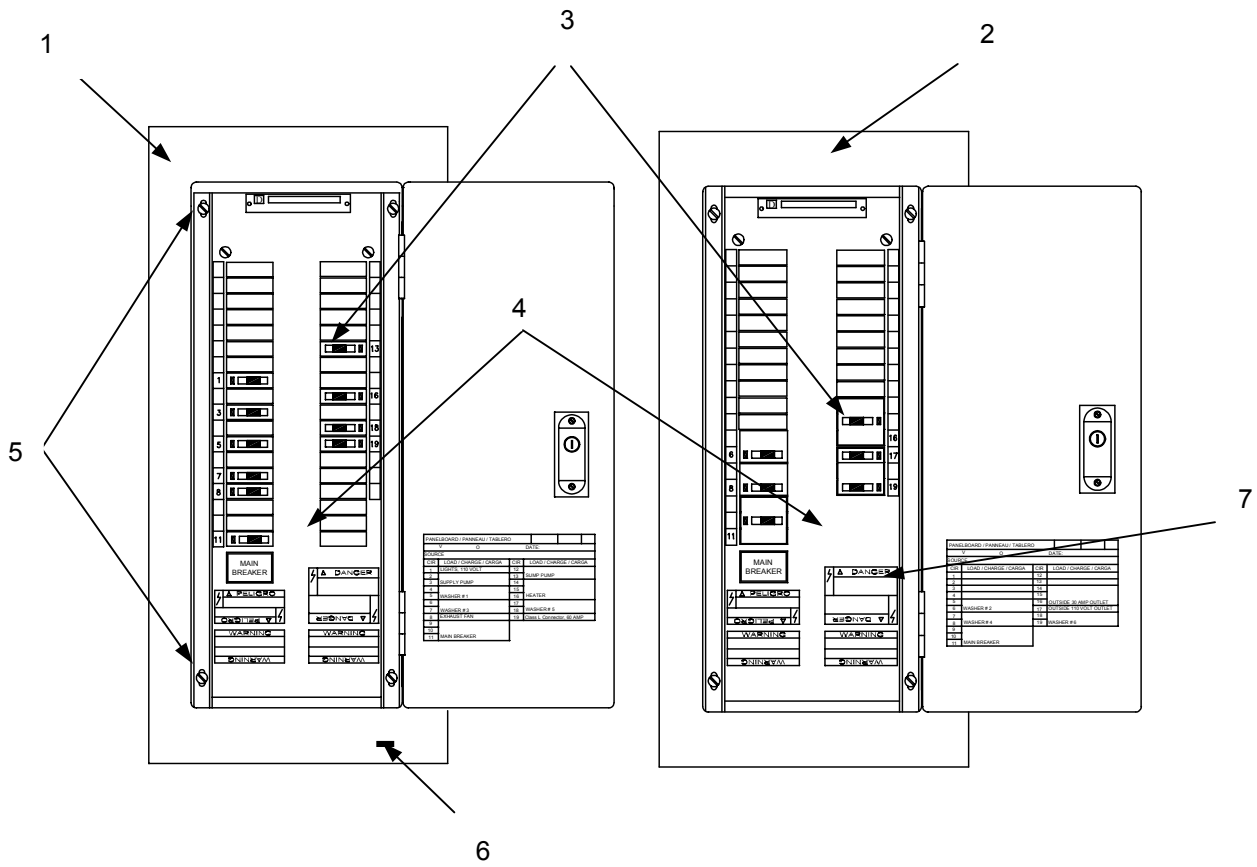

END OF WORK PACKAGE

---

**UNIT MAINTENANCE  
CONTAINERIZED SELF SERVICE LAUNDRY (CSSL)  
NSN 3510-01-485-0457  
FLUORESCENT LIGHTS  
INSPECT, REPAIR**

---

**INITIAL SETUP:****Equipment Condition**

Circuit Breaker #1 in right side power distribution panel set to OFF

**Materials/Parts**

Light Fluorescent, General Purpose  
(WP 0070 00, Table 1, Item 2)

**Tools and Special Tools**

Tool Kit General Mech. Automotive  
(WP 0041, Table 2, Item 1), Flashlight

**Personnel Required**

One

---



---

**WARNING**

---

This equipment operates at high voltages. Use extreme caution. Touching a live wire can cause serious injury or death.

**INSPECT**

1. Using a flashlight (in footlocker), inspect the fluorescent light fixtures for damage and security of mounting.
2. Check for the presence and security of the light cover **(1)**.

**REPAIR**

1. To replace a burned out light bulb **(2)** un-clasp and remove the light cover **(1)**. Remove the retainer clips **(3)** holding the light bulb in the sockets **(4)** and retain. Turn the burned out light bulb slightly and remove it from its sockets.
2. Remove the spring clips **(5)** securing the reflector **(6)** and retain. Remove the reflector.
3. After the reflector is removed, check the security of fixture mounting hardware. Tighten if necessary.
4. Disconnect the ballast wiring. Retain the wire nuts **(7)** and tag the wires. Remove the screws **(8)** holding the ballast **(9)**. Remove the ballast.
5. Secure new ballast **(9)** using retained screws **(8)**. Connect the tagged wires, securing with retained wire nuts **(7)**.
6. Install reflector **(6)** using retained spring clips **(5)**.
7. Install the new light bulbs **(2)** into the sockets and secure with retainer clips **(3)**. Place the cover **(1)** onto the housing and secure with clasps.
8. Turn circuit breaker #1 in right side power distribution panel to **ON**. Turn light switch **ON**.

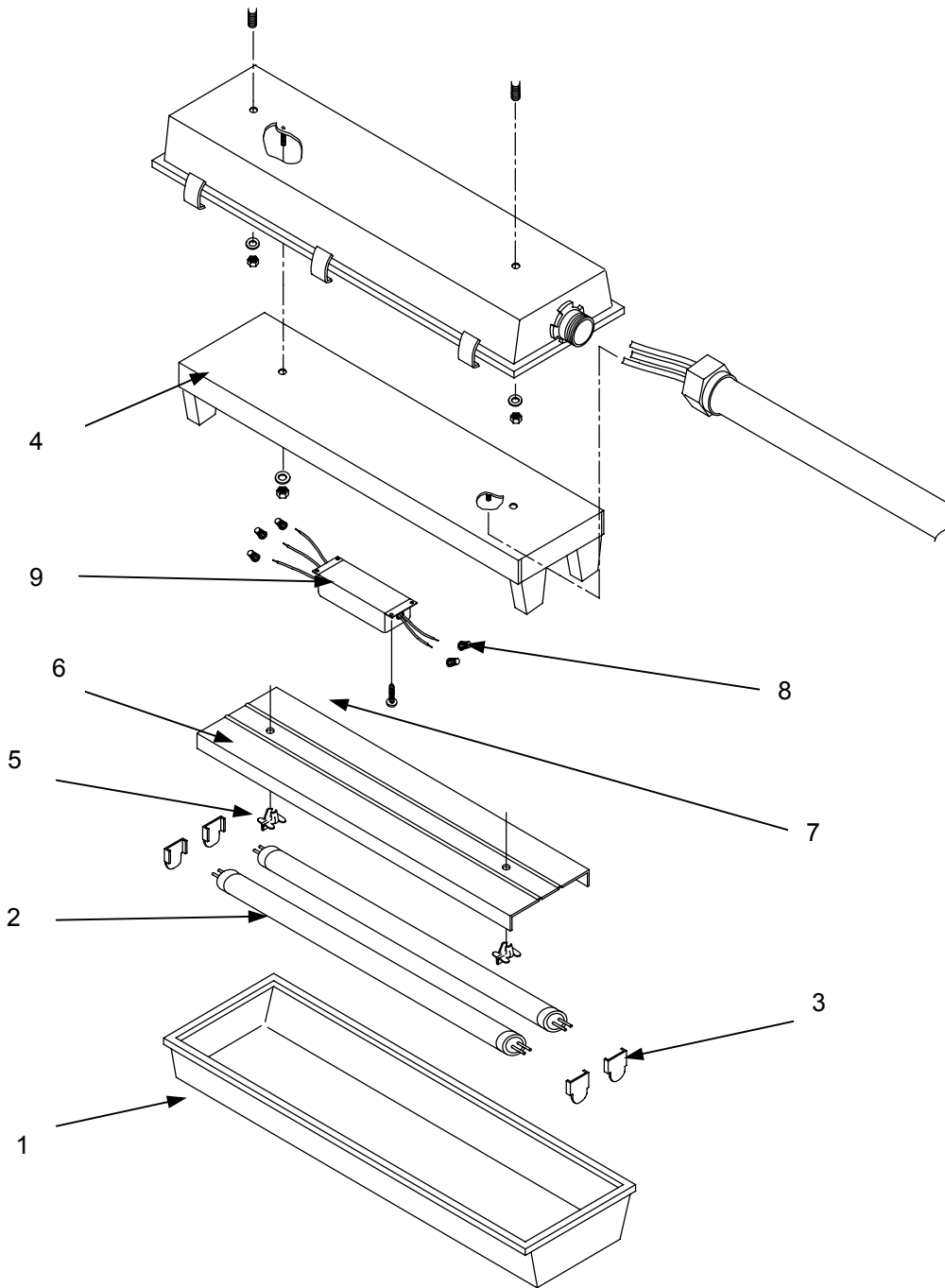

END OF WORK PACKAGE

**UNIT MAINTENANCE  
CONTAINERIZED SELF SERVICE LAUNDRY (CSSL)  
NSN 3510-01-485-0457  
INTERIOR SWITCHES AND RECEPTACLES  
INSPECT, REPLACE**

**INITIAL SETUP:**

**Equipment Condition**

Circuit breakers #10 in both left and right power distribution panels set to **OFF**

**Materials/Parts**

Flashlight

**Tools and Special Tools**

Tool Kit, General Mech. Automotive (WP 0042, Table 2, Item 1)

**Personnel Required**

One

**INSPECT**

1. Using a flashlight (in footlocker), inspect the light switch **(1)** located near the personnel entrance, and also the vent fan switch **(2)** located on the right side power distribution panel.
2. Inspect the twist-lock receptacles **(3)** located in the overhead raceway **(4)** for damage.

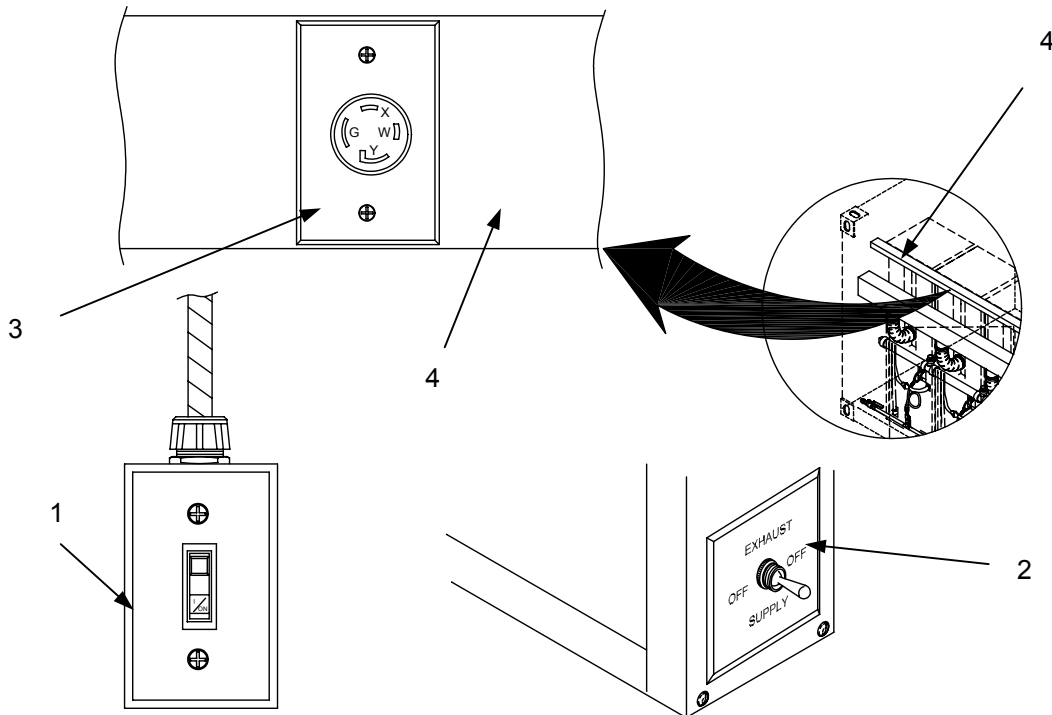

**WARNING**

This equipment operates at high voltages. Use extreme caution. Turn circuit breaker #1 in the right side power distribution panel to **OFF**, before proceeding. Touching a live wire can cause serious injury or death.

**REPLACE****Light Switch.**

1. To replace the light switch **(1)** located on the side wall at the personnel entrance, remove the cover screws **(2)** and the switch installation screws **(3)**.
2. Pull the switch from the housing **(4)**.
3. Loosen and remove the wires **(5)** from the switch **(1)**, noting the method in which they were installed.
4. To install a new switch **(1)**, attach the wires **(5)** as removed. Position the switch into the housing **(4)** and secure it with the switch installation screws **(3)**. Replace the cover and secure it with cover screws **(2)**.

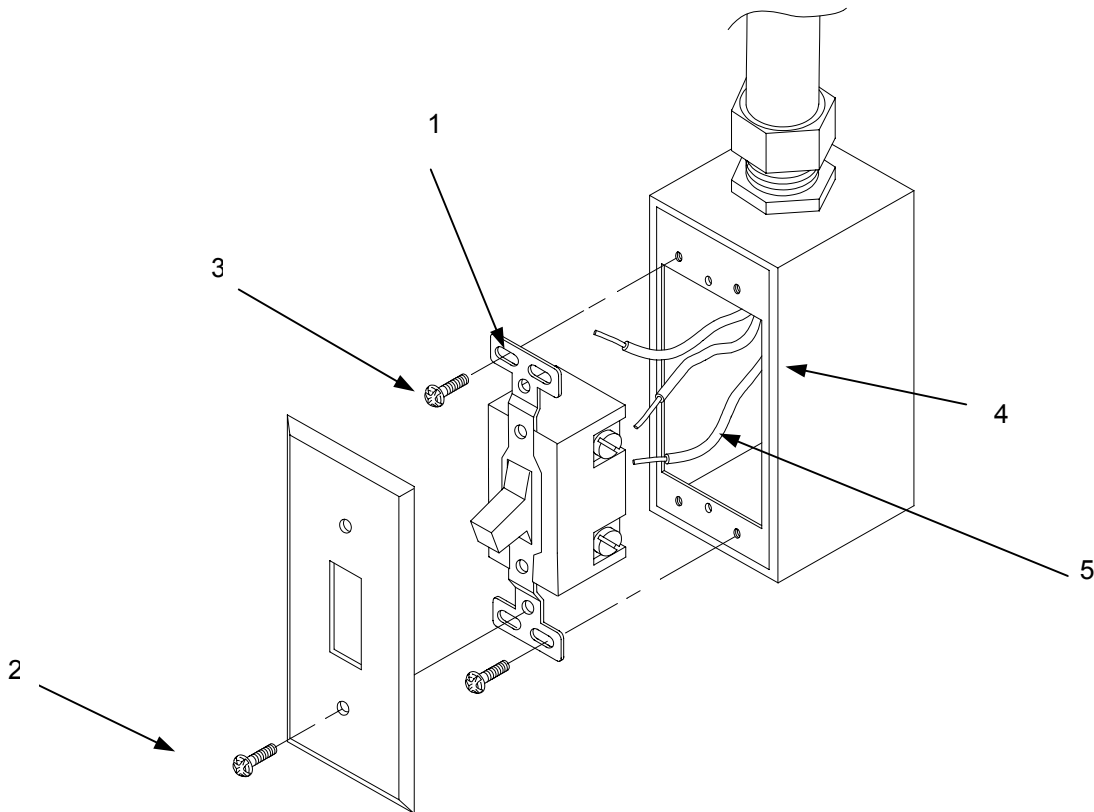

**WARNING**

This equipment operates at high voltages. Use extreme caution. Turn circuit breaker #8 in the right side power distribution panel to **OFF** and disconnect the power supply before proceeding. Touching a live wire can cause serious injury or death.

**Vent Fan Switch.**

1. To replace the vent fan switch **(1)** located on the right side power distribution panel **(2)**, remove the power distribution panel front cover assembly, refer to work package 0030 00 for the power distribution panel procedures.
2. Remove the threaded retainer **(3)** from the outside of the panel. Remove the four retaining screws and the switch cover plate **(5)**.
3. Remove the hex nut **(6)** securing the switch to the power distribution panel **(2)**.
4. Pull the vent fan switch **(1)** back and away from the power distribution panel **(2)**.

**NOTE**

Ensure that each wire is re-connected to the appropriate terminal on the switch.

5. Remove the wires one at a time and re-connect each wire individually to the new switch.
6. After connections are complete, replace the switch and install the hex nut **(6)** on the outside of the panel.
7. Install the four retaining screws **(4)**, the switch cover plate **(5)** and the threaded retainer **(3)**.
8. Replace the power distribution panel front cover assembly as described in work package 0031 00.

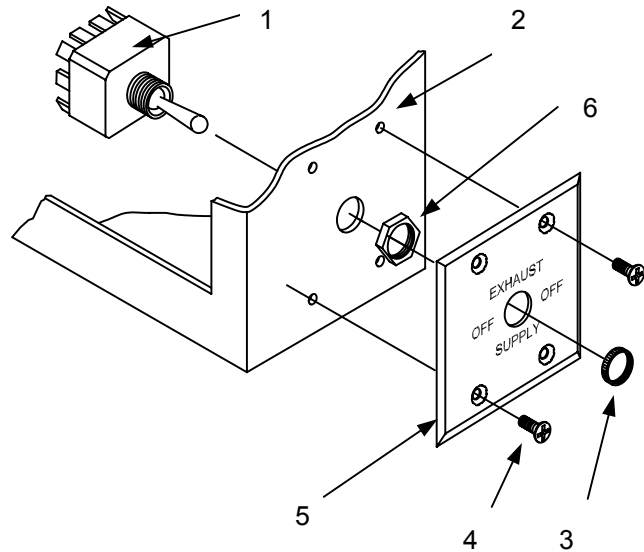
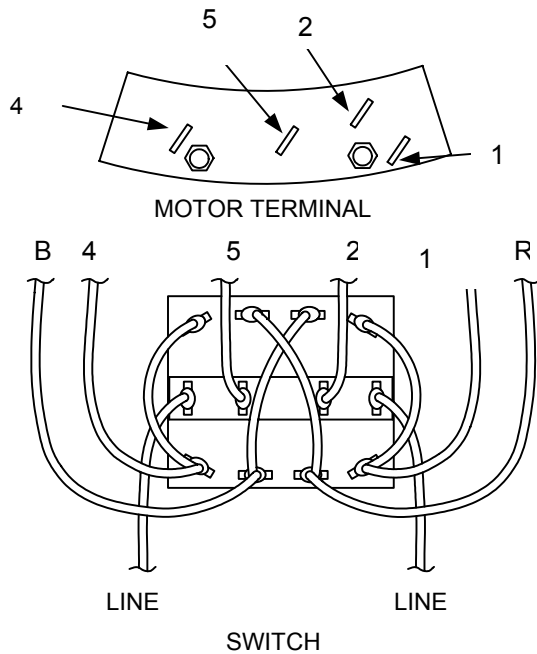

**Twist-Lock Receptacle.**



**WARNING**

This equipment operates at high voltages. Use extreme caution. Turn circuit breakers #10 in both power distribution panels to **OFF**, before proceeding. Touching a live wire can cause serious injury or death.

**NOTE**

Personnel in the 5<sup>th</sup> percentile size group may require a step aid during this procedure. Use the side doors for easier access to the

1. To remove the twist-lock receptacle, remove the screws (1) securing the wall plate (2).
2. Remove the screws (3) securing the twist-lock receptacle (4) to the overhead raceway (5).
3. Pull the receptacle (4) out from the raceway to gain access to the wire connections.
4. Loosen and remove the wires (6) from the receptacle (4), noting the method of attachment.
5. Discard the defective receptacle.
6. To install a new receptacle, connect the wires (6) in the manner in which they were removed.
7. Place the receptacle (4) in the raceway (5) and secure it with screws (3).
8. Install the wall plate (2) using screws (1).



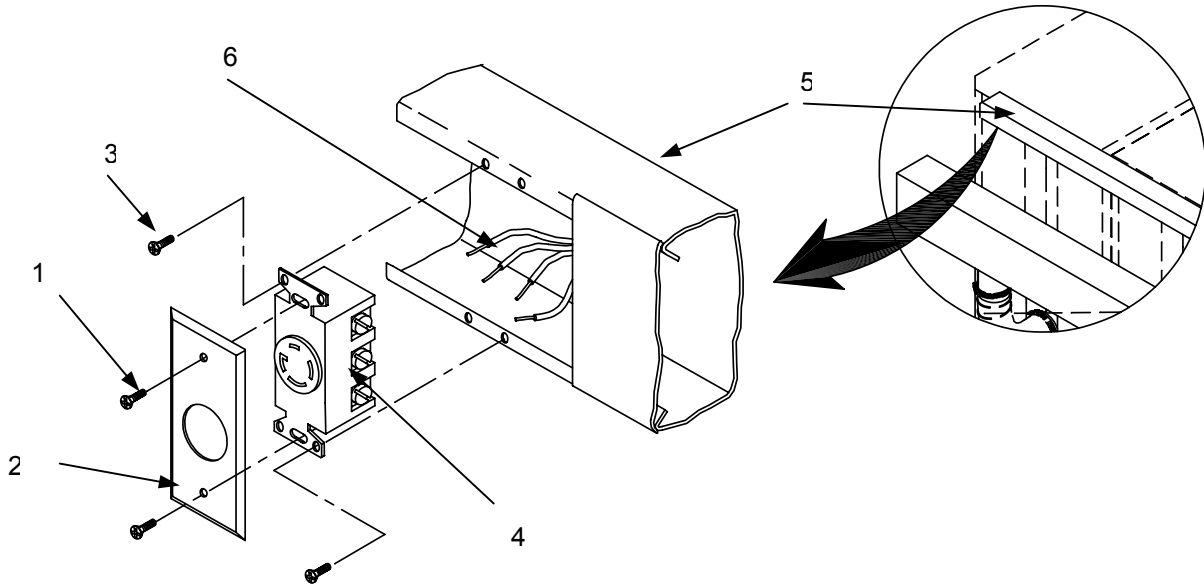

END OF WORK PACKAGE

THIS PAGE INTENTIONALLY LEFT BLANK

---

**UNIT MAINTENANCE  
CONTAINERIZED SELF SERVICE LAUNDRY (CSSL)  
NSN 3510-01-485-0457  
FRESHWATER PUMP AND INTERNAL FRESHWATER LINE  
INSPECT, SERVICE**

---

**INITIAL SETUP:****Equipment Condition**CSSL set up, Freshwater pump turned **OFF****Materials/Parts**

None

**Tools and Special Tools**

Tool Kit, General Mech. Automotive (WP 0042, Table 2, Item 1)

Pipe Wrench 18" (WP 0042, Table 2, Item 4)

Pipe Wrench 10" (WP 0042, Table 2, Item 5)

**Personnel Required**

One



---

**WARNING**

---

The freshwater pump operates at high voltages. Use extreme caution. Make sure the freshwater pump is turned off (circuit breaker #3 in right side power distribution panel) before proceeding. Touching a live wire can cause serious injury or death.

**INSPECT**

1. Visually inspect the freshwater pump **(1)** for damage. Check the condition of the mounting screws **(2)** holding the pump to the mounting plate. Tighten if loose. Check the priming stem **(3)** and tighten if loose.
2. Inspect the pump power cord **(3)**. If the cord is frayed, broken or loose, refer to Direct Support Maintenance.
3. Inspect the copper freshwater line **(4)** from the utility wall **(5)** to the end of the line behind washer/dryer #6 **(6)**.
4. Check for leaks that indicate loose connections or damage to the line. Using both pipe wrenches, tighten any connections that are loose and/or leak.

**SERVICE**

1. Connect the garden hose to the hose fitting **(7)** at the end of the line behind washer/dryer #6 and open the ball valve **(8)**. Let the system drain.
2. Remove the strainer plugs **(9)** and **(10)**. Remove and inspect the strainers **(11)** and **(12)**. Clean, or replace the strainer(s), if necessary.
3. Reinstall the strainers **(11)** and **(12)** and plugs **(9)** and **(10)**. Close the ball valve **(8)**. Remove the garden hose. Drain it, coil it, then connect the garden hose end-to-end and store it in the footlocker.

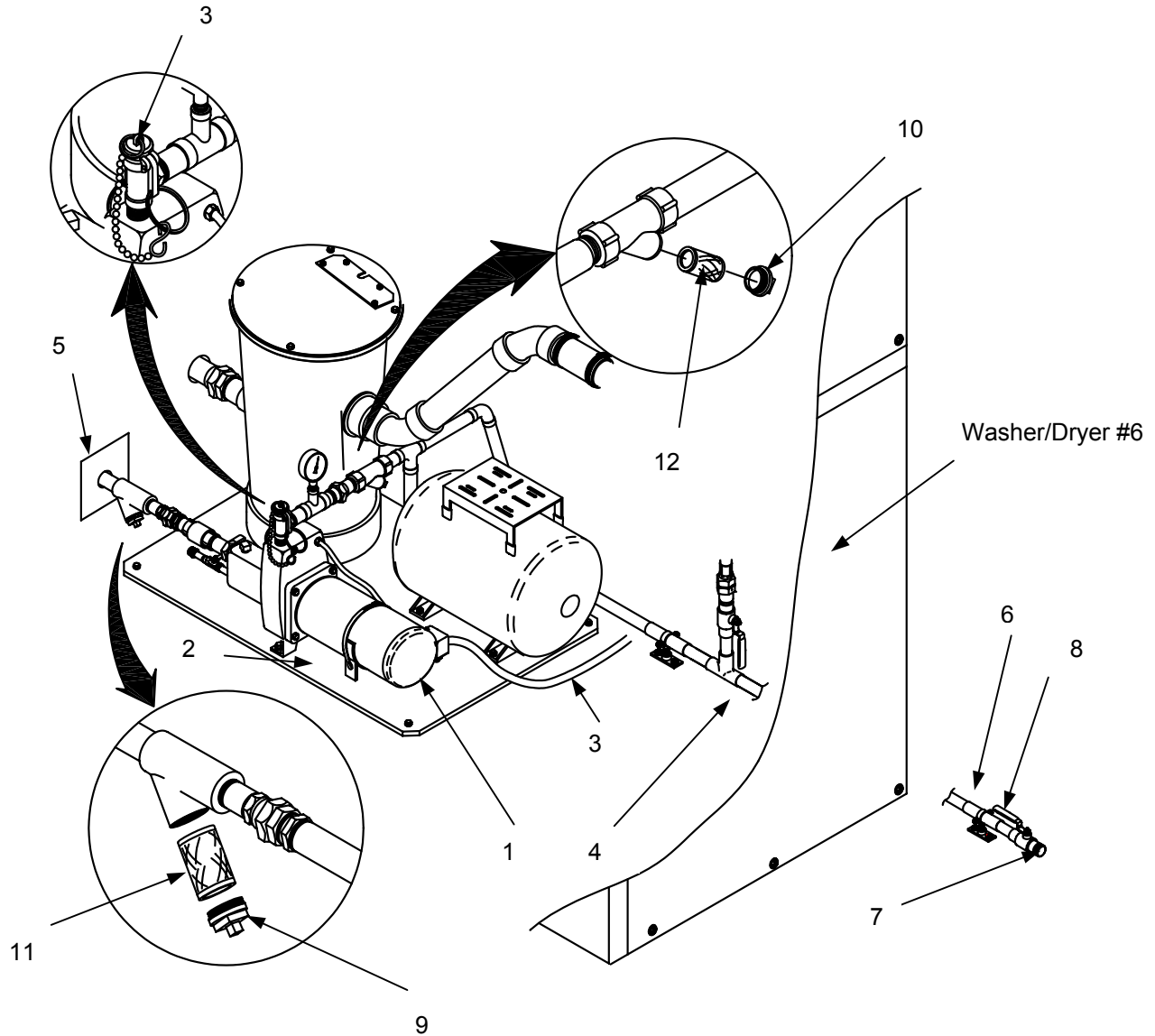

END OF WORK PACKAGE

**UNIT MAINTENANCE**  
**CONTAINERIZED SELF SERVICE LAUNDRY (CSSL)**  
**NSN 3510-01-485-0457**  
**PRESSURE TANK**  
**INSPECT**

**INITIAL SETUP:****Equipment Condition**

CSSL set-up, but not in operation

**Materials/Parts**

None

**Tools and Special Tools**

Tool Kit, General Mech. Automotive (WP 0042, Table 2, Item 1)

**Personnel Required**

One

**INSPECT**

1. Inspect the pressure tank **(1)** for damage and corrosion. Inspect the tank floor mounts **(2)** for rust, missing or loose hardware. Inspect the pressure valve **(3)** for damage, corrosion or looseness.
2. Check the tank **(1)** and the step **(4)** for rust and corrosion. Using common tools, tighten the mounting hardware as necessary. Report a damaged pressure tank that leaks, shows excessive rust, or has a defective pressure valve, to Direct Support Maintenance.

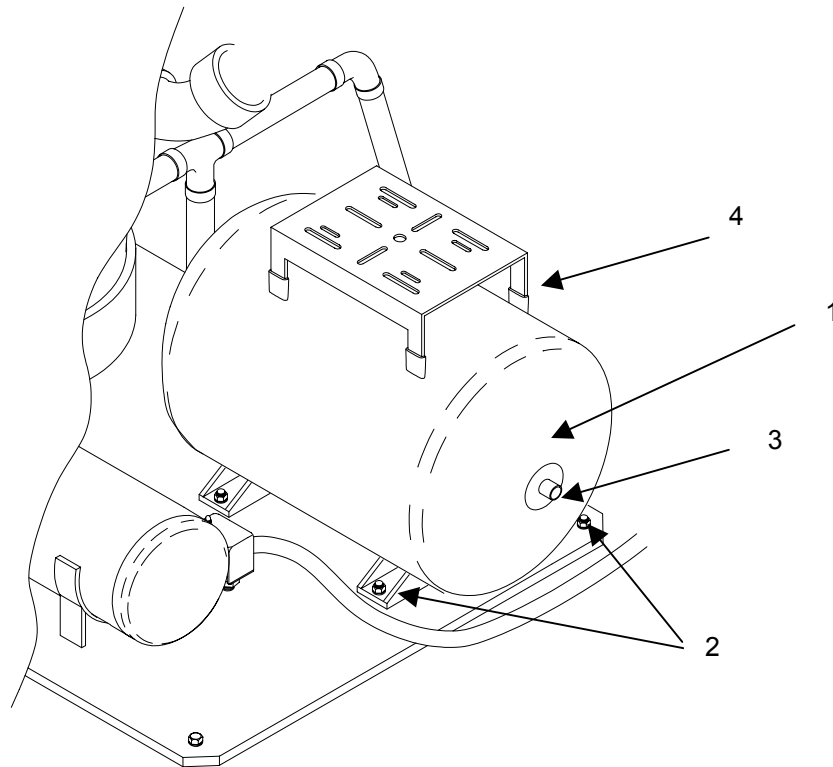
**END OF WORK PACKAGE**

THIS PAGE INTENTIONALLY LEFT BLANK

**UNIT MAINTENANCE  
CONTAINERIZED SELF SERVICE LAUNDRY (CSSL)  
NSN 3510-01-485-0457  
PRESSURE SWITCH/GAUGE  
INSPECT**

**INITIAL SETUP:**

**Equipment Condition**  
CSSL in operation

**Materials/Parts**  
None

**Tools and Special Tools**  
None

**Personnel Required**  
One

**INSPECT**

1. Inspect the pressure switch **(1)** and gauge **(2)** for damage.
2. Check for legibility of the scale, internal corrosion, and leaks.
3. Observe proper functioning of pressure switch and gauge during normal operation of the CSSL. The pressure gauge should move between 20 and 40 PSI during normal operation. The water pump **(3)** should start when the pressure reaches 20 PSI and stop at approximately 40 PSI.
4. Report an inoperable pressure switch or gauge to direct support maintenance.
5. Visually check the pressure switch power cord **(4)** for damage.

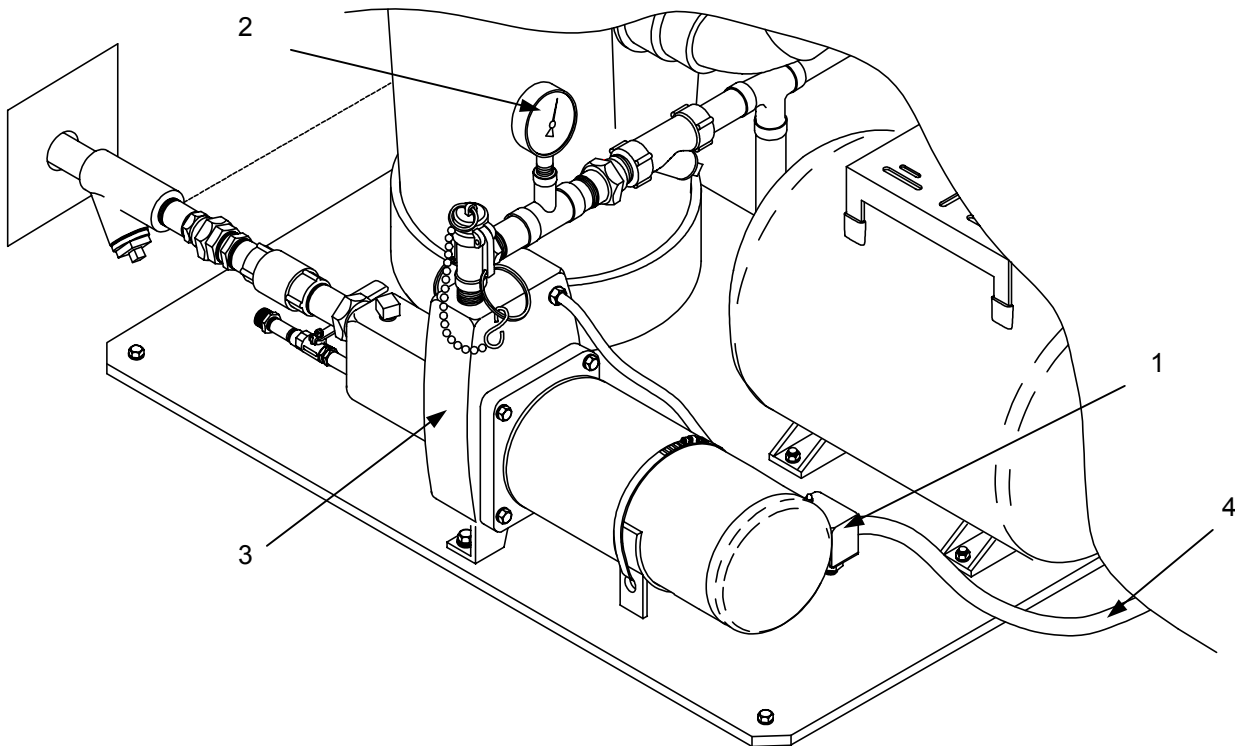
**END OF WORK PACKAGE**

THIS PAGE INTENTIONALLY LEFT BLANK



---

**UNIT MAINTENANCE**  
**CONTAINERIZED SELF SERVICE LAUNDRY (CSSL)**  
**NSN 3510-01-485-0457**  
**SUMP PUMP AND FLOAT SWITCH**  
**INSPECT**

---

**INITIAL SETUP:****Equipment Condition**

CSSL set-up, but not in operation

**Materials/Parts**

Wiping Rags, (WP 0070, Table 1, Item 1)

**Tools and Special Tools**

Tool Kit General Mech. Automotive (WP 0042, Table 2, Item 1)

**Personnel Required**

One

**INSPECT**

1. After all the washers have completed their cycles and the sump pump **(1)** has completed evacuating the wastewater tank **(2)**, open the wastewater tank cover **(3)** by loosening the fasteners **(4)**.
2. Visually inspect the sump pump **(1)** for damage.
3. Check the Sump Pump power cord **(5)** and the float switch cable **(6)** for damage.
4. Inspect the float switch **(7)** for damage and check that it operates freely.
5. Report a sump pump that is not functioning properly, or has a frayed or otherwise damaged power cord to direct support maintenance.
6. Report a damaged or inoperative float switch to direct support maintenance.
7. Replace the cover **(3)** and tighten the fasteners **(4)**.

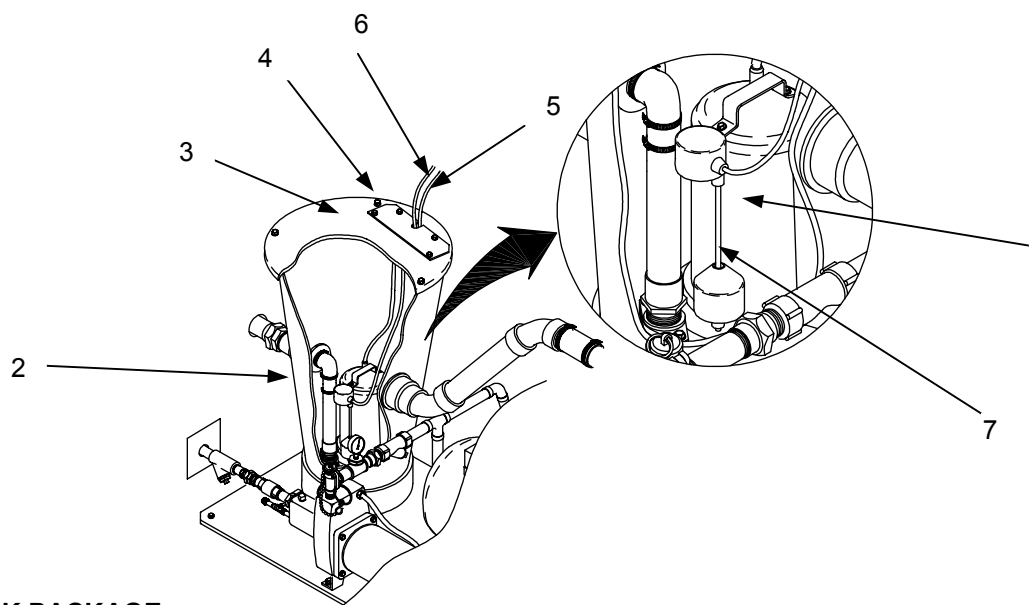
**END OF WORK PACKAGE**

THIS PAGE INTENTIONALLY LEFT BLANK

---

**UNIT MAINTENANCE**  
**CONTAINERIZED SELF SERVICE LAUNDRY (CSSL)**  
**NSN 3510-01-485-0457**  
**WASTEWATER PVC PIPES**  
**INSPECT**

---

**INITIAL SETUP:**

**Equipment Condition**  
CSSL in operation

**Materials/Parts**  
Wiping Rags (WP 0070, Table 1, Item 1)

**Tools and Special Tools**  
None required

**Personnel Required**  
One

---

**INSPECT**

1. Inspect the internal PVC Wastewater collection lines including the 3" collection (1), the outflow line (2), the cleanout fitting (3), wastewater pipe holders (4), and the wastewater panel adapter fitting (5) for leaks due to damage or improper connections.
2. Open the side doors and inspect the collection line (1). Report any repairs required on the wastewater piping to Direct Support Maintenance.

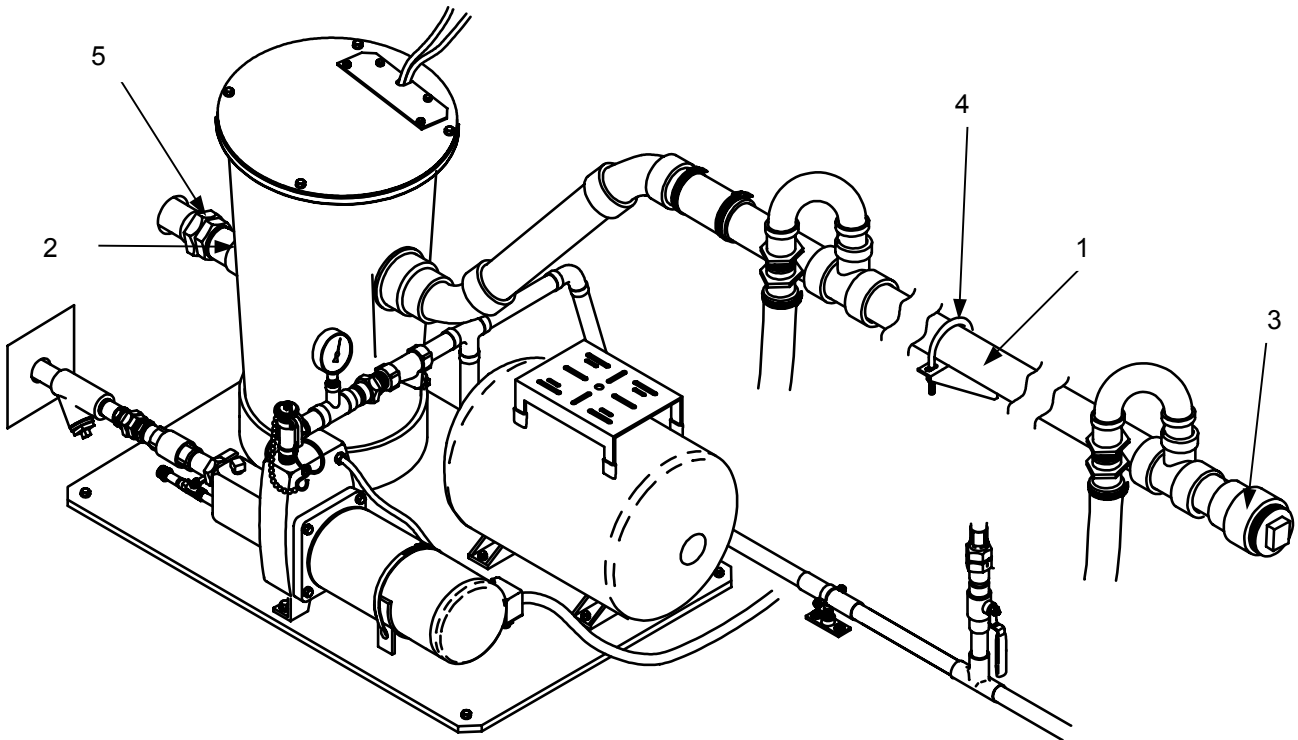

**END OF WORK PACKAGE**

THIS PAGE INTENTIONALLY LEFT BLANK

**UNIT MAINTENANCE  
CONTAINERIZED SELF SERVICE LAUNDRY (CSSL)  
NSN 3510-01-485-0457  
WASHER AND DRYER  
INSPECT**

**INITIAL SETUP:**

**Equipment Condition**

CSSL in operation

**Materials/Parts**

Wiping Rags (WP 0070, Table 1, Item 1)

**Tools and Special Tools**

Tool Kit, General Mech. Automotive (WP 0042, Table 2, Item 1)

**Personnel Required**

One

**INSPECT**

1. Inspect each of the six washers/dryers (1) for damage.
2. Check the power cords (2) for cuts or fraying, and any broken twist-lock connectors (3).
3. Check the condition of the freshwater (4) and drain hoses (5). Tighten the hoses if necessary.
4. Check the condition of the dryer exhaust hoses (6). Tighten the hose clamps (7) if necessary. Report the replacement of a crushed, torn, or ripped hose to direct support maintenance. Confirm that the washer/dryer assemblies are mounted (8) securely. It will be necessary to slide the washer (lower) unit out on its frame to gain access to the mounting hardware (8). Report an inoperative washer/dryer to direct support maintenance.

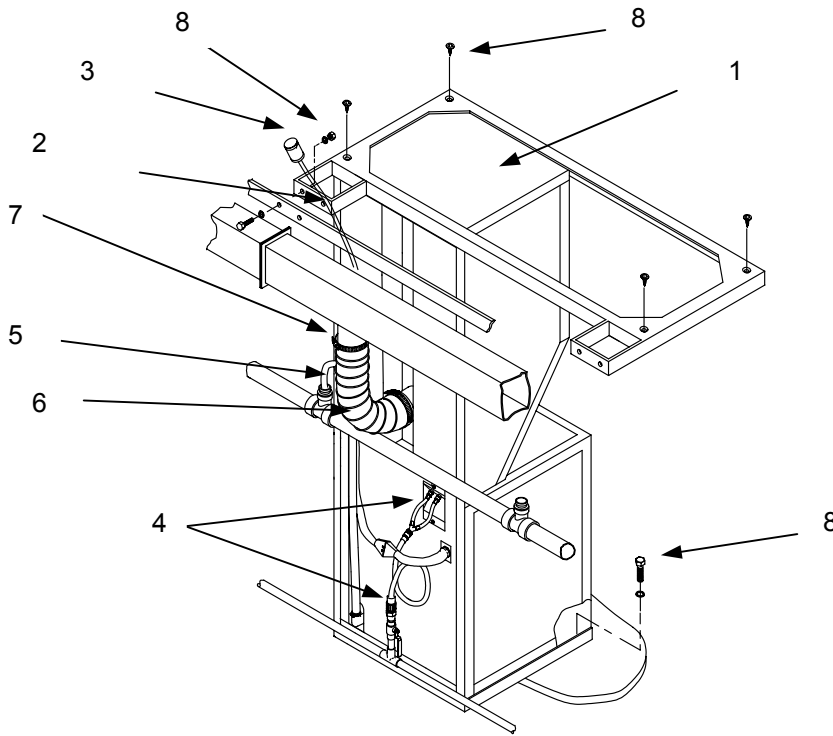

**END OF WORK PACKAGE**

THIS PAGE INTENTIONALLY LEFT BLANK

**UNIT MAINTENANCE  
CONTAINERIZED SELF SERVICE LAUNDRY (CSSL)  
NSN 3510-01-485-0457  
VENT FAN  
INSPECT**

**INITIAL SETUP:**

**Equipment Condition**

CSSL in operation, Circuit Breaker #8 (right side power distribution panel) is turned OFF.

**Materials/Parts**

None Required

**Tools and Special Tools**

Tool Kit General Mech. Automotive (WP 0042, Table 2, Item 1)

**Personnel Required**

One



**WARNING**

This equipment operates at high voltages. Use extreme caution. Turn OFF power supply (circuit breaker #8 in right side power distribution panel). Touching a live wire can cause serious injury or death.

**INSPECT**

1. Remove the dust screen (1) from the utility wall (2). Retain the securing hardware.
2. Inspect the dust screen and vent fan (3) from inside the container for damage.
3. Check the condition of the blades and that they are moving freely.
4. Remove debris caught in the fan housing as necessary. Replace the dust screen on the utility wall and secure, using the retained hardware. Refer an inoperative or damaged vent fan to Direct Support Maintenance.

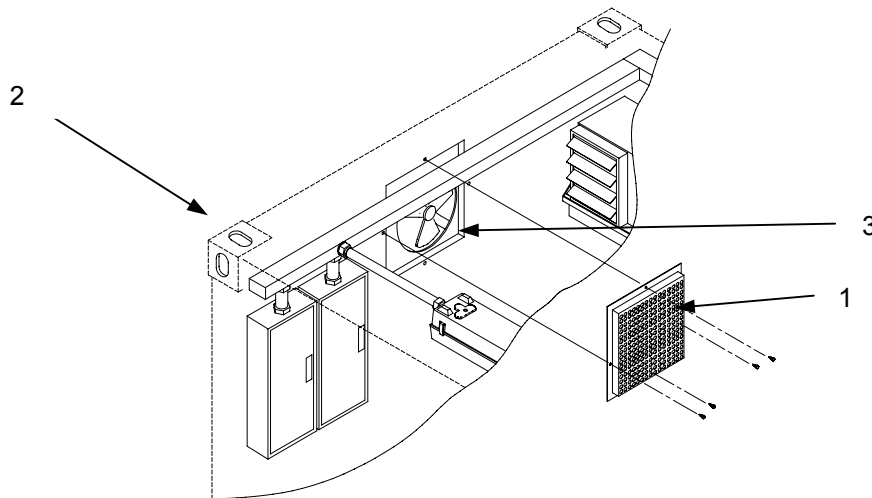

**END OF WORK PACKAGE**

THIS PAGE INTENTIONALLY LEFT BLANK



**UNIT MAINTENANCE**  
**CONTAINERIZED SELF SERVICE LAUNDRY (CSSL)**  
**NSN 3510-01-485-0457**  
**SPACE HEATER**  
**INSPECT**

**INITIAL SETUP:****Equipment Condition**

CSSL set up, circuit breakers #10 in both left and right side Power Distribution Panels turned OFF.

**Materials/Parts**

None

**Tools and Special Tools**

Tool Kit General Mech. Automotive (WP 0042, Table 2, Item 1)

**Personnel Required**

One



**WARNING**

This equipment operates at high voltages. Use extreme caution. Turn OFF power supply (circuit breaker #15 in right and left side power distribution panels). Touching a live wire can cause serious injury or death.

**INSPECT**

1. With circuit breaker #15 on right side power distribution panel set to **OFF**, inspect the space heater (1) for damage.
2. Check the condition of the power cord (2) for cuts, fraying, and exposed wires.
3. Check the heater installation hardware (3) and tighten if necessary. Inspect fan at rear of heater for damage and /or debris.
4. If debris is found inside the grill, refer to direct support maintenance.

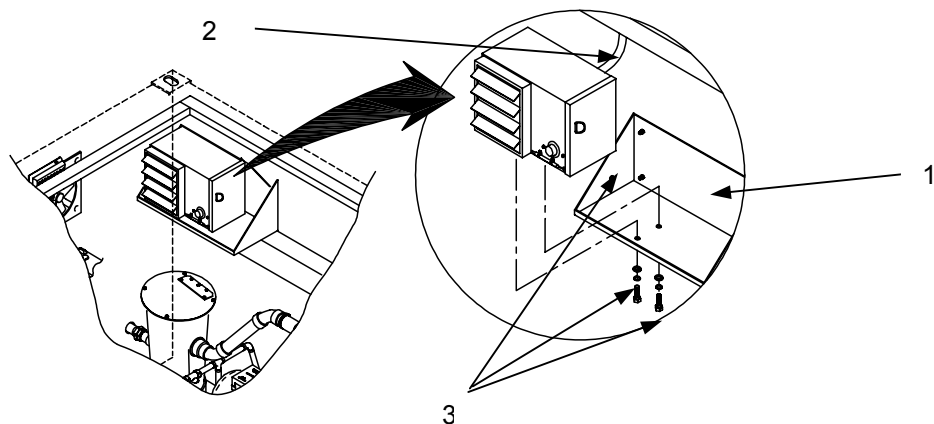

**END OF WORK PACKAGE**

THIS PAGE INTENTIONALLY LEFT BLANK

---

**UNIT MAINTENANCE**  
**CONTAINERIZED SELF SERVICE LAUNDRY (CSSL)**  
**NSN 3510-01-485-0457**  
**WATER HOSES**  
**INSPECT, REPAIR, REPLACE**

---

**INITIAL SETUP:****Equipment Condition**

CSSL not in operation, water hoses disconnected

**Materials/Parts**

Wiping Rags (WP 0070, Table 1, Items 1)

Gasket (WP 0070, Table 1, Item 19)

Hose Clamp (WP 0070, Table 1, Item 15)

**Tools and Special Tools**

Tool Kit, General Mech. Automotive (WP 0042, Table 2, Item 1)

**Personnel Required**

One



---

**WARNING**

---

Keep the freshwater and wastewater hoses separate at all times. Do not switch components such as seals or coupling halves between the freshwater and wastewater hoses as this may result in health hazards due to biological contamination.

**INSPECT**

1. Inspect the freshwater and wastewater hoses for material damage, leaks, frayed material, presence of gaskets.
2. Check for proper operation of the Quick Disconnect (QD) hose couplings.

## REPAIR

### Hose.

1. Repair a hose by replacing a gasket or QD coupling half as required and as described below. Replace an entire hose when damaged beyond repair.
2. To replace a gasket, use long-nose pliers to remove the gasket **(1)** from female QD coupling half **(2)**. Ensure entire gasket is removed, and groove **(3)** is clear. Use long-nose pliers, to install a new gasket.

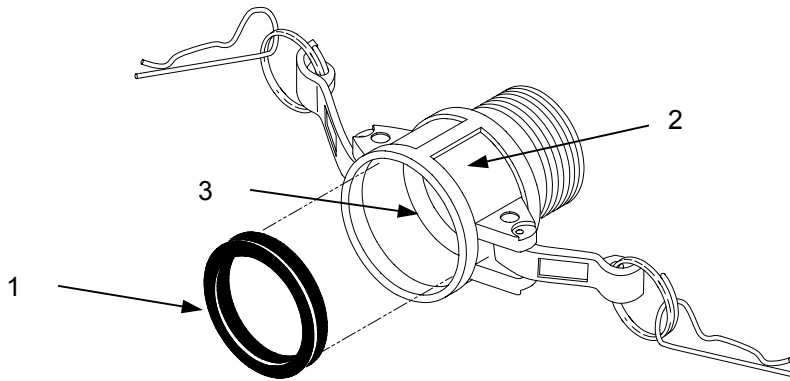

### Quick Disconnect (QD) Fitting.

1. To replace the QD fitting, use a screwdriver to loosen the water hose clamp **(1)** while holding the damaged QD coupling half **(2)** on the hose **(3)**.
2. Remove the damaged QD coupling half **(2)** from the hose **(3)**.
3. Place a new or serviceable QD coupling half **(2)** on the hose **(3)**.
4. Place a new or serviceable water hose clamp over the end of the hose and the sleeve of the coupling. Use a screwdriver to tighten the clamp **(1)**.

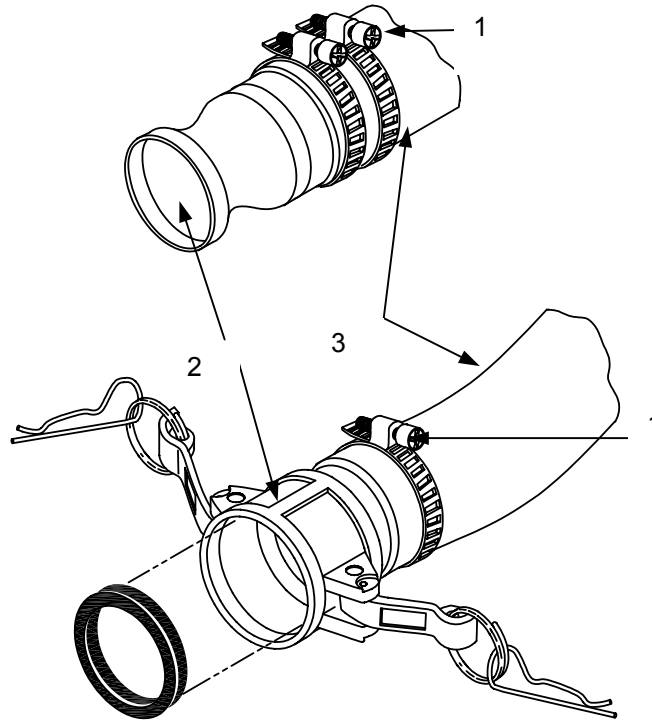

## REPLACE

1. Replace a freshwater or wastewater hose that leaks or is frayed and worn.
2. Refer to work package 0062 00, Repair Parts and Special Tools List, Water Hoses, for ordering a replacement hose.

**END OF WORK PACKAGE**

THIS PAGE INTENTIONALLY LEFT BLANK

**UNIT MAINTENANCE**  
**CONTAINERIZED SELF SERVICE LAUNDRY (CSSL)**  
**NSN 3510-01-485-0457**  
**CSSL MODIFIED END SECTION**  
**INSPECT, REPLACE**

**INITIAL SETUP:****Equipment Condition**

CSSL set-up, but not in operation

**Materials/Parts**

None

**Tools and Special Tools**

Tent Repair Kit (WP 0042, Table 2, Item 9)

**Personnel Required**

One

**INSPECT**

1. Inspect the CSSL Modified End Section (1) for material damage such as rips, tears, missing hardware, condition of hook and pile fasteners (2) and tie down straps (3).
2. Check to see if the foot loops (4) and grommets (5) are operational.

**REPLACE**

1. Replace the entire Modified End Section (1) when unserviceable.
2. Refer to Work Package 0005 00 as applicable.

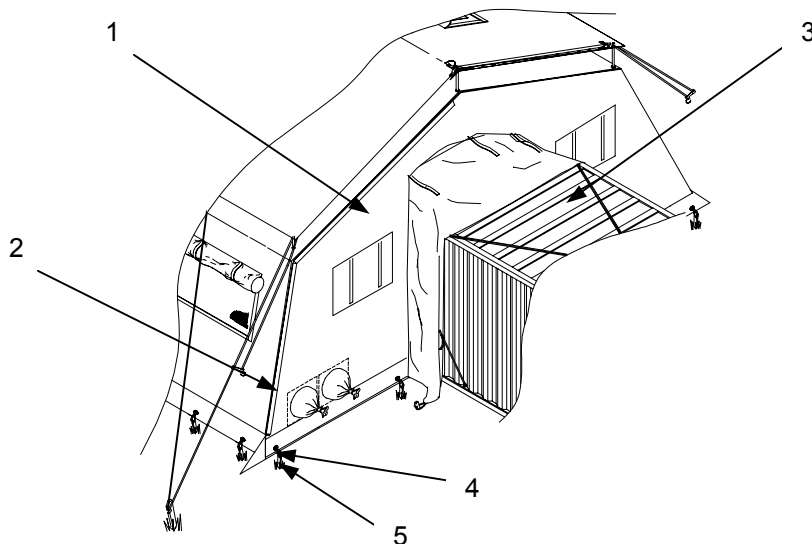
**END OF WORK PACKAGE**

THIS PAGE INTENTIONALLY LEFT BLANK



---

**UNIT MAINTENANCE**  
**CONTAINERIZED SELF SERVICE LAUNDRY (CSSL)**  
**NSN 3510-01-485-0457**  
**ROOFGRIP**  
**INSPECT, REPLACE**

---

**INITIAL SETUP:****Equipment Condition**

CSSL not stacked

**Materials/Parts**

Wiping Rags (WP 0070, Table 1, Item 1)

**Tools and Special Tools**

Tool Kit, Org. Maintenance Common No.1

**Personnel Required**

One

---

**INSPECT**

1. Inspect the cargo container roofgrip (**1**) for missing, bent, broken or rusted grip, or a grip that will not fold.
2. Check to see if the mounting bolts (**2**) are tight.
3. Report a damaged, or inoperable roofgrip to direct support maintenance.

**REPLACE**

1. To replace a damaged roofgrip, (**1**), remove the mounting hardware (**2**).
2. Replace with a new roofgrip and install the mounting hardware as removed.

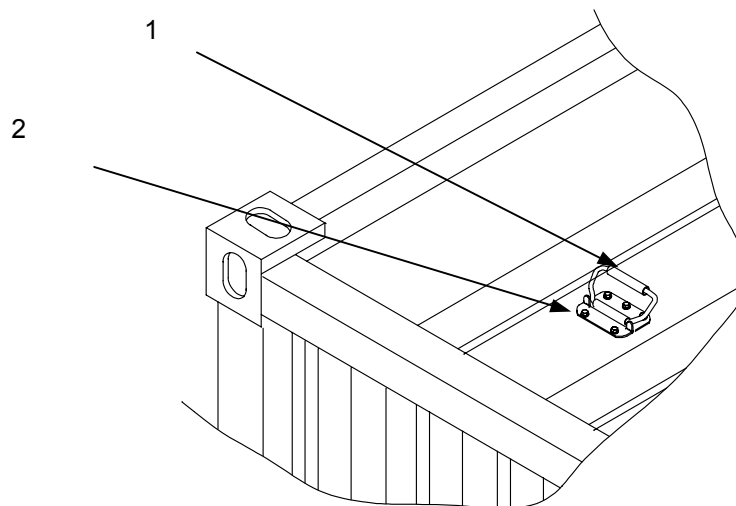
**END OF WORK PACKAGE**

THIS PAGE INTENTIONALLY LEFT BLANK

**TM 10 3510-224-13&P**

**CHAPTER 6**  
**DIRECT SUPPORT MAINTENANCE INSTRUCTIONS**  
**FOR THE**  
**CONTAINERIZED SELF SERVICE LAUNDRY**  
**(CSSL)**  
**MODEL B**

THIS PAGE INTENTIONALLY LEFT BLANK

---

**CONTAINERIZED SELF SERVICE LAUNDRY (CSSL)  
NSN 3510-01-485-0457  
DIRECT SUPPORT TROUBLESHOOTING PROCEDURES**

---

The Malfunction Symptom Index lists common malfunctions that may occur during laundry inspection and operation. Find the malfunction the laundry is having in the index and go to the given troubleshooting paragraph in the following pages.

These charts cannot list all the malfunctions that may occur, or all the tests and inspections needed to find the problem. If your malfunction is not listed in the index or is not correctable through this troubleshooting index, notify your supervisor.

DO NOT START A TASK UNTIL:

- You understand the task
- You understand what you are to do
- You understand what is needed to do the work
- You have the things you need

#### MALFUNCTION SYMPTOM INDEX

Malfunction or Symptom	Refer to Troubleshooting Procedure
System Power Loss	1
Internal Component Power Loss	2
External Component Power Loss	3



---

**WARNING**

---

Only MOS 51R, 52C, 52D, or 52G qualified personnel must perform the procedures described in this work package. When measuring power supply, ensure that the multimeter is set to read AC Volts. Serious injury and death can result from electrical shock.

**Procedure 1: System Power Loss**

**INITIAL SETUP:**

**Equipment Condition**  
 CSSL set-up, but not in operation

**Materials/Parts**  
 None

**Maintenance Level**  
 Direct Support

**Personnel Required**  
 One

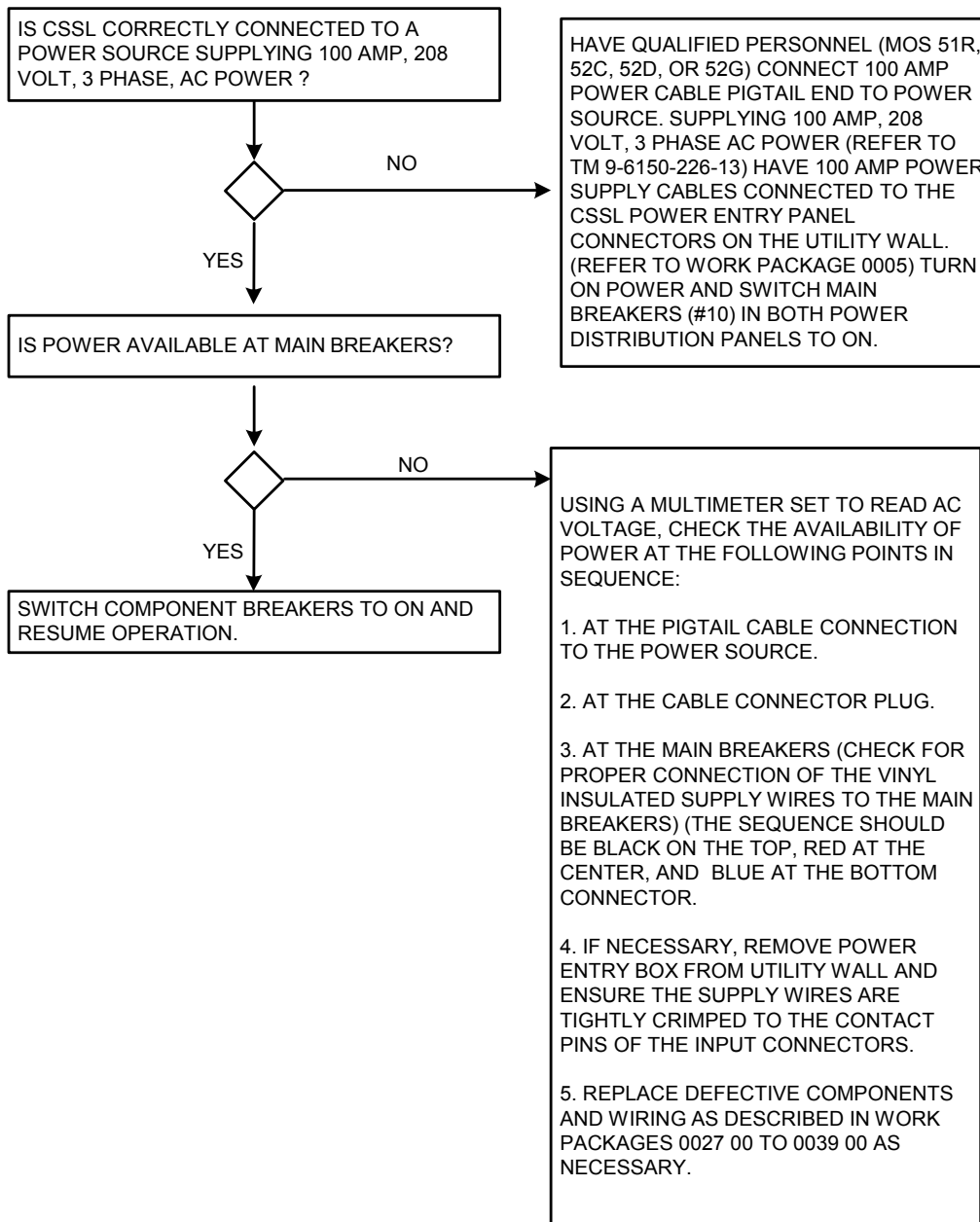

**Procedure 2: Internal Component Power Loss**

**INITIAL SETUP:**

**Equipment Condition**  
CSSL set-up, but not in operation

**Material/Parts**  
None

**Maintenance Level**  
Direct Support

**Personnel Required**  
One

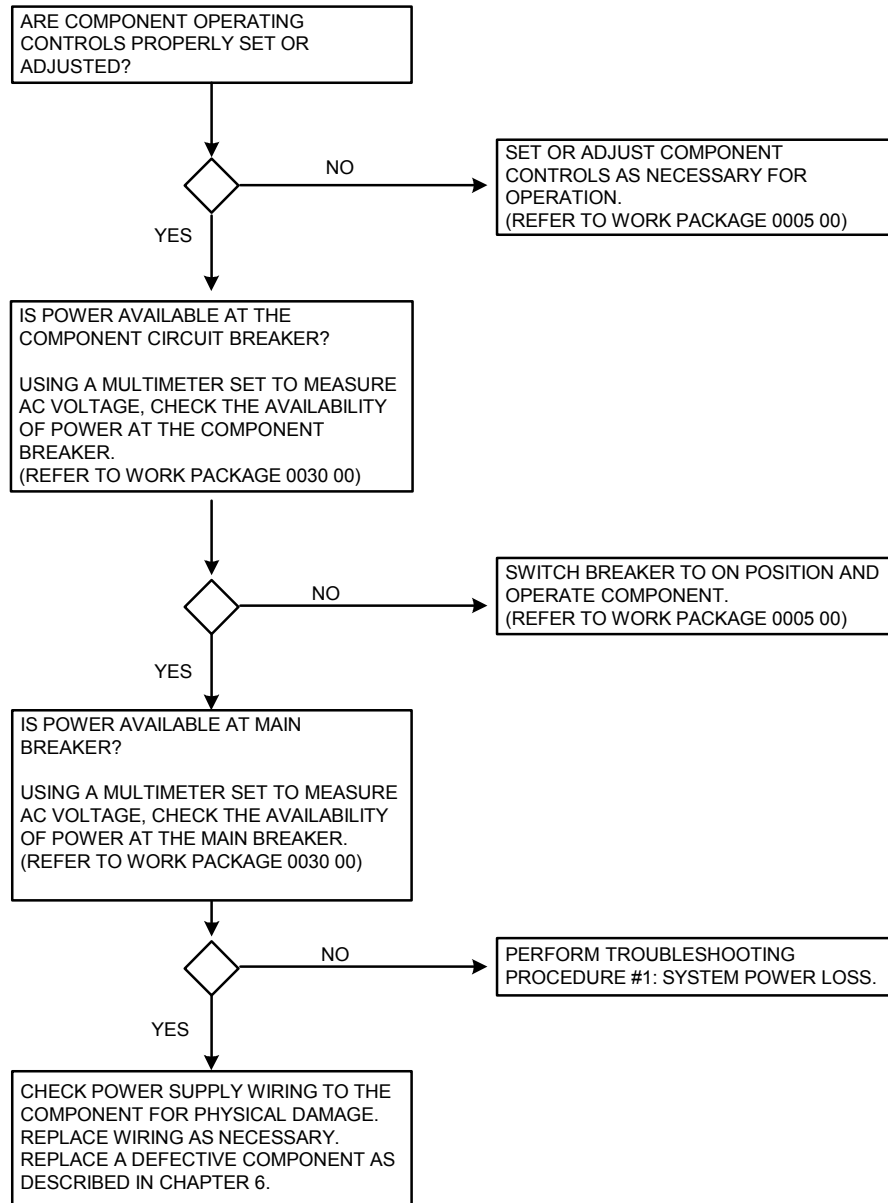

**Procedure 3: External Component Power Loss**

**INITIAL SETUP:**

**Equipment Condition**  
 CSSL set-up, but not in operation

**Materials/Parts**  
 None

**Maintenance Level**  
 Direct Support

**Personnel Required**  
 One

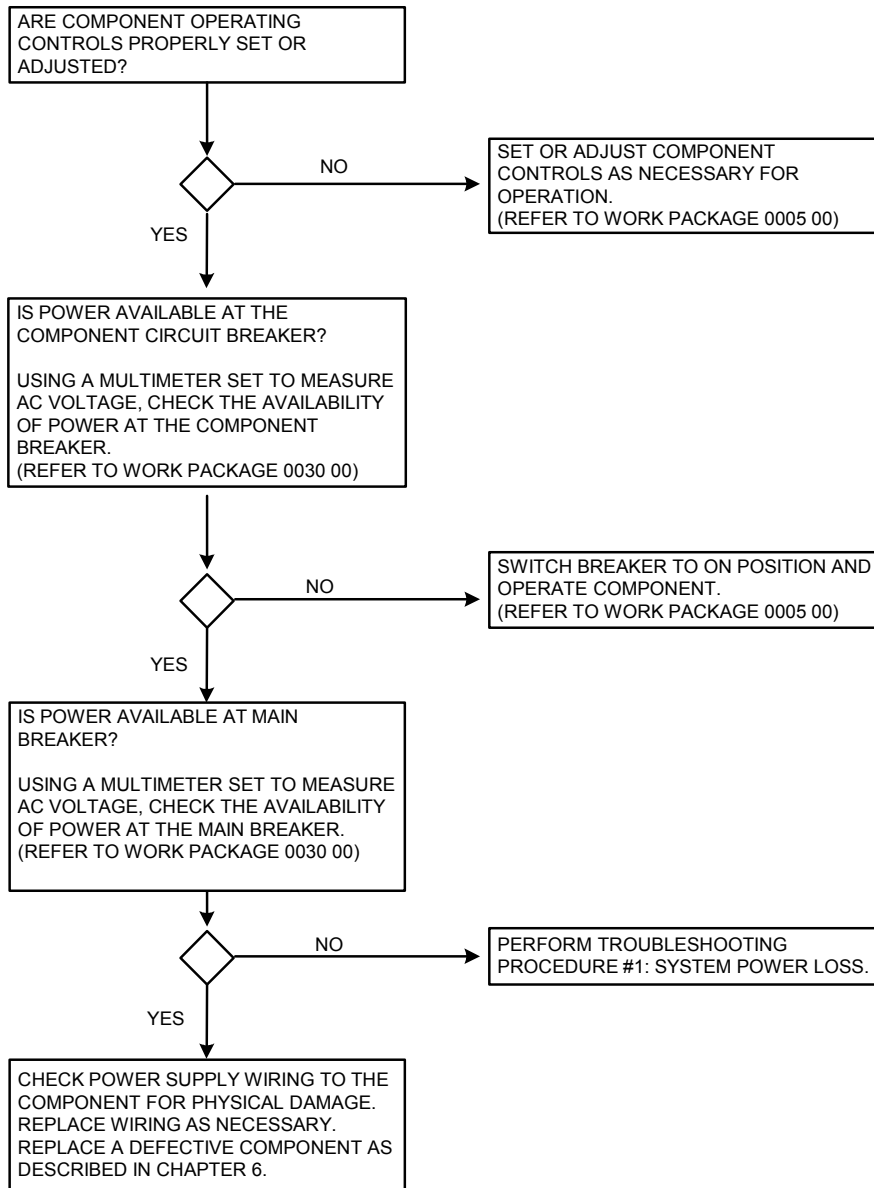

**END OF WORK PACKAGE**



---

**UNIT MAINTENANCE**  
**CONTAINERIZED SELF SERVICE LAUNDRY (CSSL)**  
**NSN 3510-01-485-0457**  
**MODIFIED FOLDING STEP**  
**INSPECT, REPLACE**

---

**INITIAL SETUP:****Equipment Condition**

CSSL not stacked

**Materials/Parts**

Wiping Rags (WP 0070, Table 1, Item 1)

**Tools and Special Tools**Tool Kit, Org. Maintenance Common No.1 (WP 0042,  
Table 2, Item 1)**Personnel Required**

One

---

**INSPECT**

1. Inspect the cargo container modified folding step **(1)** for a missing, bent, broken or rusted steps that will not fold.
2. Check to see if the mounting bolts **(2)** are tight.

**REPLACE**

1. To replace a modified folding step **(1)**, remove two hex head mounting bolts **(2)**.
2. Replace with a new step and install the mounting bolts as removed.

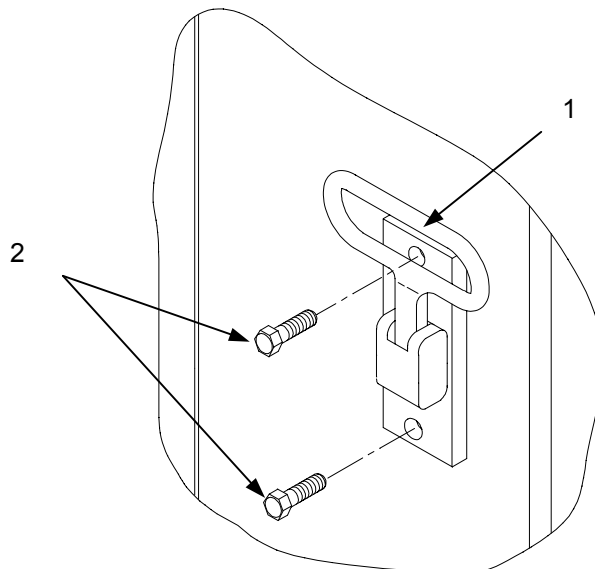
**END OF WORK PACKAGE**

THIS PAGE INTENTIONALLY LEFT BLANK

---

**DIRECT SUPPORT MAINTENANCE  
CONTAINERIZED SELF SERVICE LAUNDRY (CSSL)  
NSN 3510-01-485-0457  
POWER ENTRY CONNECTORS  
TEST**

---

**INITIAL SETUP:****Equipment Condition**

CSSL not in operation

**Materials/Parts**

Wiping Rags (WP 0070 00, Table 1, Item 1)  
Tags, Marking, (WP 0070 00, Table 1, Item 8)  
Tape, EI Insul. (WP 0070 00, Table 1, Item 13)

**Tools and Special Tools**

Tool Kit, Electronic Equipment (WP 0042, Table 2,  
Item 3)

**Personnel Required**

Two

---

**NOTE**

---

Before proceeding, check the 100 AMP Pigtail power cable for serviceability as described in TM 9-6150-226-13.



---

**WARNING**

---

This equipment operates at high voltages. Use extreme caution, observe all warnings, and follow all safety procedures. Touching a live wire can cause serious injury or death.

**TEST**

1. With all power supply cables disconnected from the power entry panel **(1)**, remove the panel from the utility wall.
2. Check the security of the crimped wires **(2)** on connectors J1, J2, and J4 by pulling on each wire.
3. Check that wires are tightly attached to the GFCI Receptacle **(3)**. Check the condition of the wires. Note any cuts, chaffing or abrasions in the insulation where wires are exposed.
4. Reinstall the power entry panel.
5. With power reconnected to the entry box connectors J1 and J2, use a multimeter to read AC voltage to check the availability of power at the main breakers **(4)** on the power distribution panels **(5)** and **(6)**. Refer to WP 0030 00).
6. To check the function of the GFCI receptacle **(3)** and 20 AMP Connector plug **(7)**, place circuit breakers 17 on panel **(5)** and circuit breaker 16 on panel **(6)**, respectively, in the **ON** position.
7. Check for availability of power at the breakers. (Replace a defective breaker as described in work package 0030 00). If power is available at the breakers, test the GFCI and 20 AMP Receptacle from the outside.

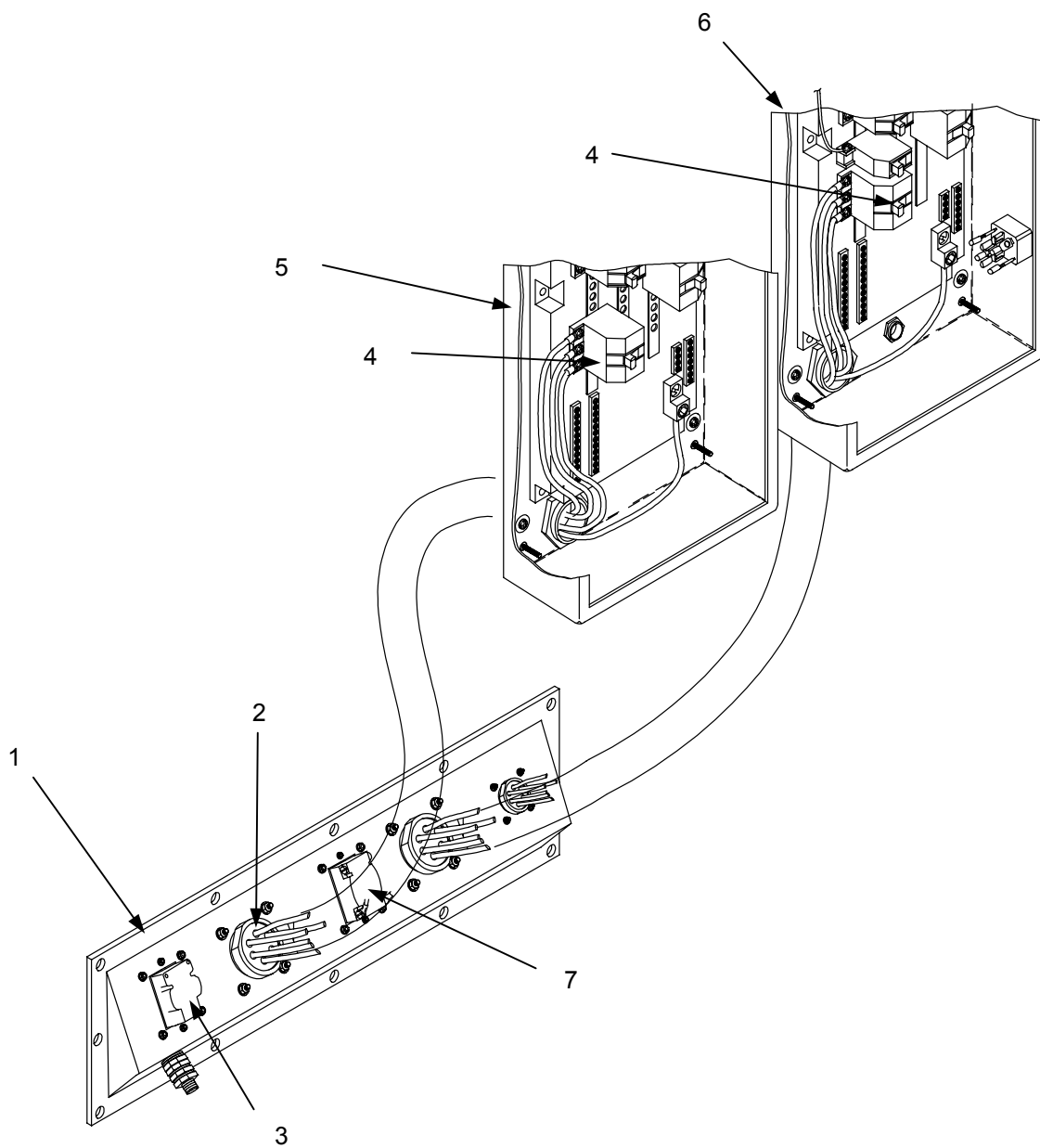

END OF WORK PACKAGE

**DIRECT SUPPORT MAINTENANCE  
CONTAINERIZED SELF SERVICE LAUNDRY (CSSL)  
NSN 3510-01-485-0457  
POWER DISTRIBUTION PANEL  
TEST, REPLACE**

**INITIAL SETUP:**

**Equipment Condition**

CSSL shut down, power connected and turned to OFF

**Materials/Parts**

Wiping Rags (WP 0070 00, Table 1, Item 1)  
Tags, Marking (WP 0070 00 Table 1, Item 8)  
Tape, elec. Ins.(WP 0070 00 Table 1, Item 13)

**Tools and Special Tools**

Tool Kit, Electrical Equipment (WP 0042, Table 2, Item 3)

**Personnel Required**

One



**WARNING**

This equipment operates at high voltage. Use extreme caution during testing procedure. Touching a live wire can cause serious injury or death. Only MOS 51R, 52C, 52D, 52G or a qualified civilian must perform this procedure.

**TEST**

1. Connect the 100 AMP power to the power entry panel plug(s)(1) and (2). Using a multimeter set to read AC Voltage, determine the availability of power at both power distribution panels main breakers (#10) (3).
2. Test individual breakers as necessary to isolate a malfunction.

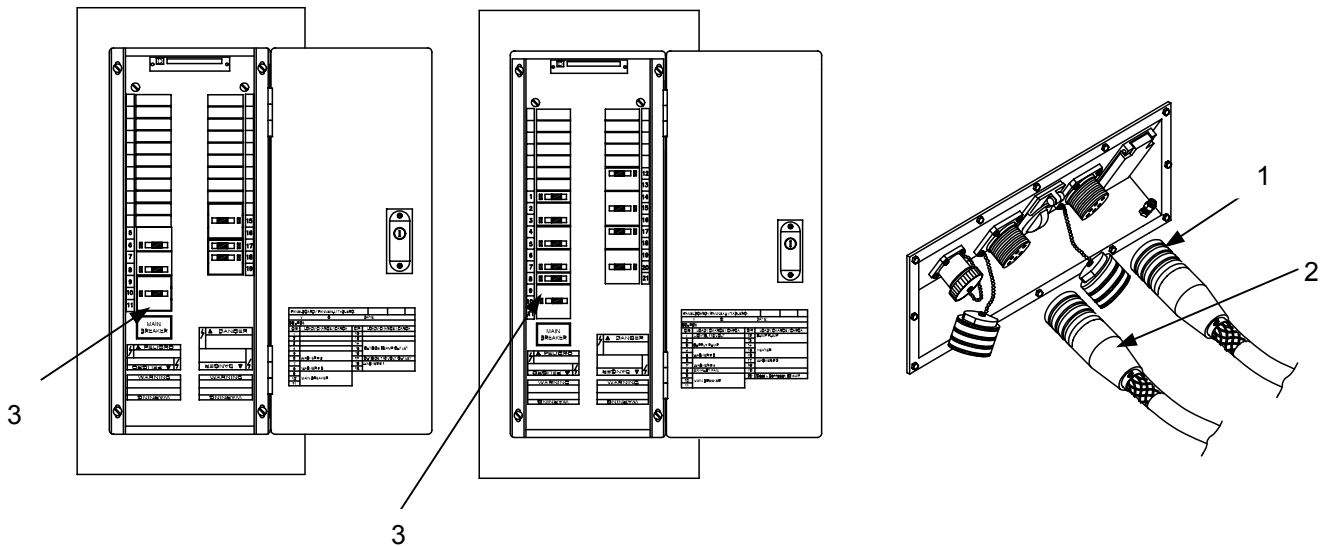

**REPLACE**

As necessary, replace a main breaker or an individual circuit breaker as described in the following procedures.



**WARNING**

This equipment operates at high voltage. Use extreme caution during test procedure. Touching a live wire can cause serious injury or death. Only MOS 51R, 52C, 52D, 52G or a qualified civilian must perform this procedure.

**Main Breaker.**

1. Open the circuit breaker panel doors (1).
2. Set all circuit breakers (2) to OFF.
3. Disconnect power from the power entry panel (3).

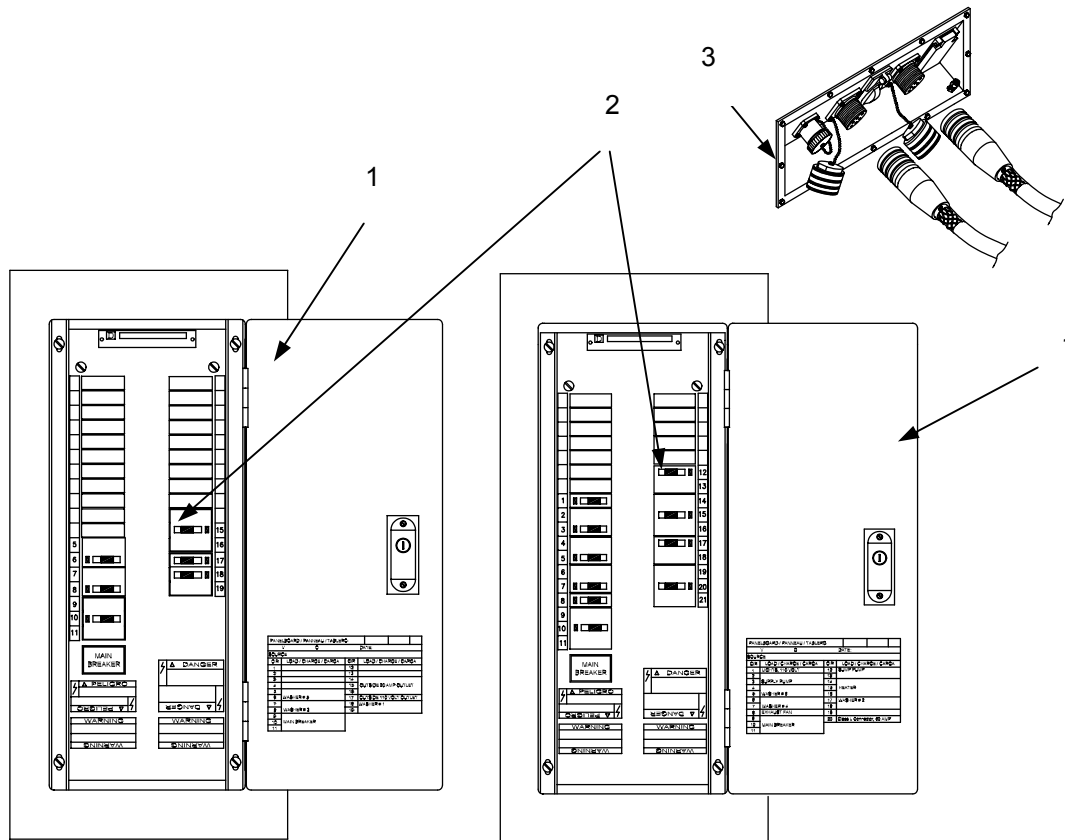

4. Remove and retain the four screws (4) on the panel cover (5) and remove the cover and door (1).
5. Remove and tag the wires (6) from the faulty breaker.

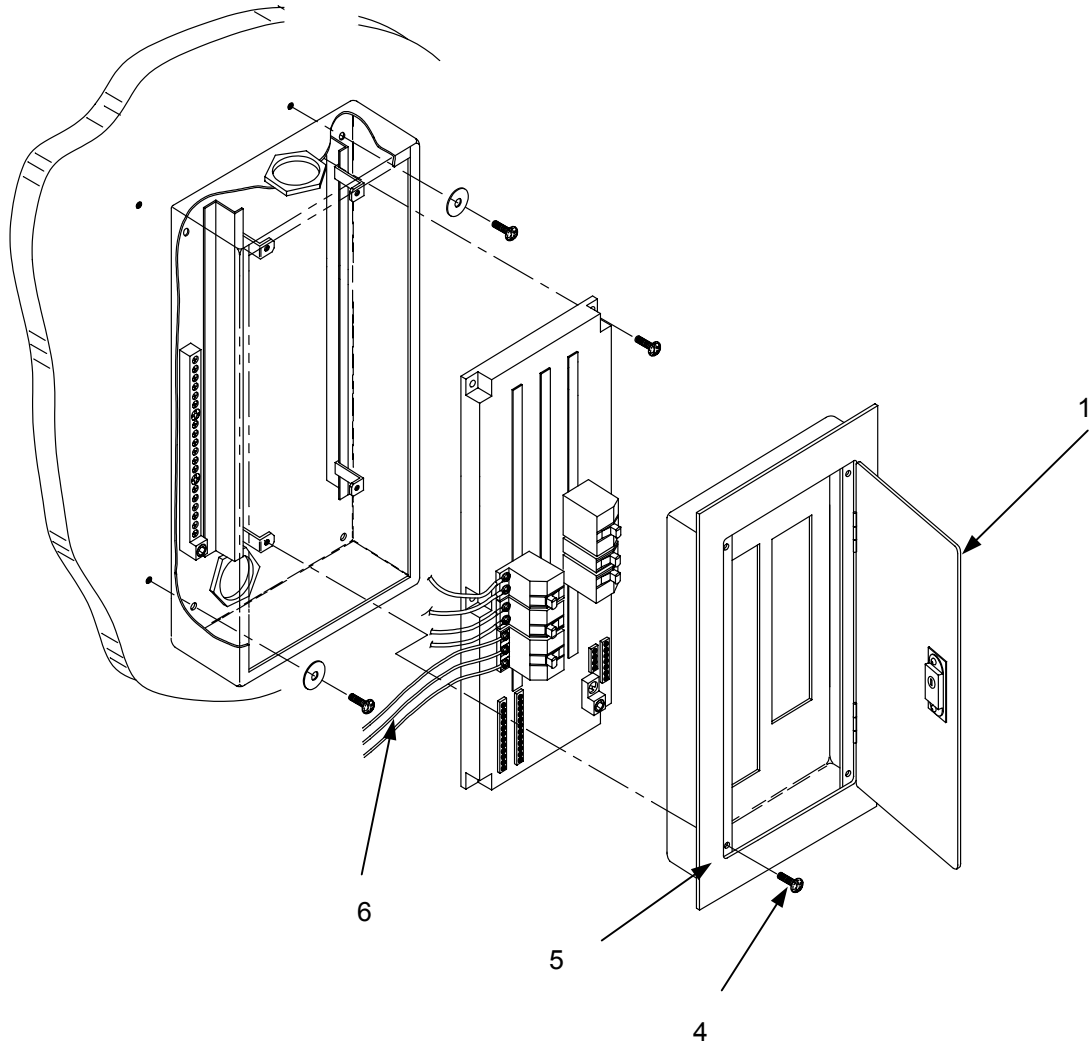

6. Re-connect the tagged wires on the breakers (1).
7. Install individual breakers (1) on the breaker panel (2) by clipping them to the panel.
8. Place the cover and door (3) on the bracket (4) and install four screws (5) to secure it.
9. Close the circuit breaker panel door.

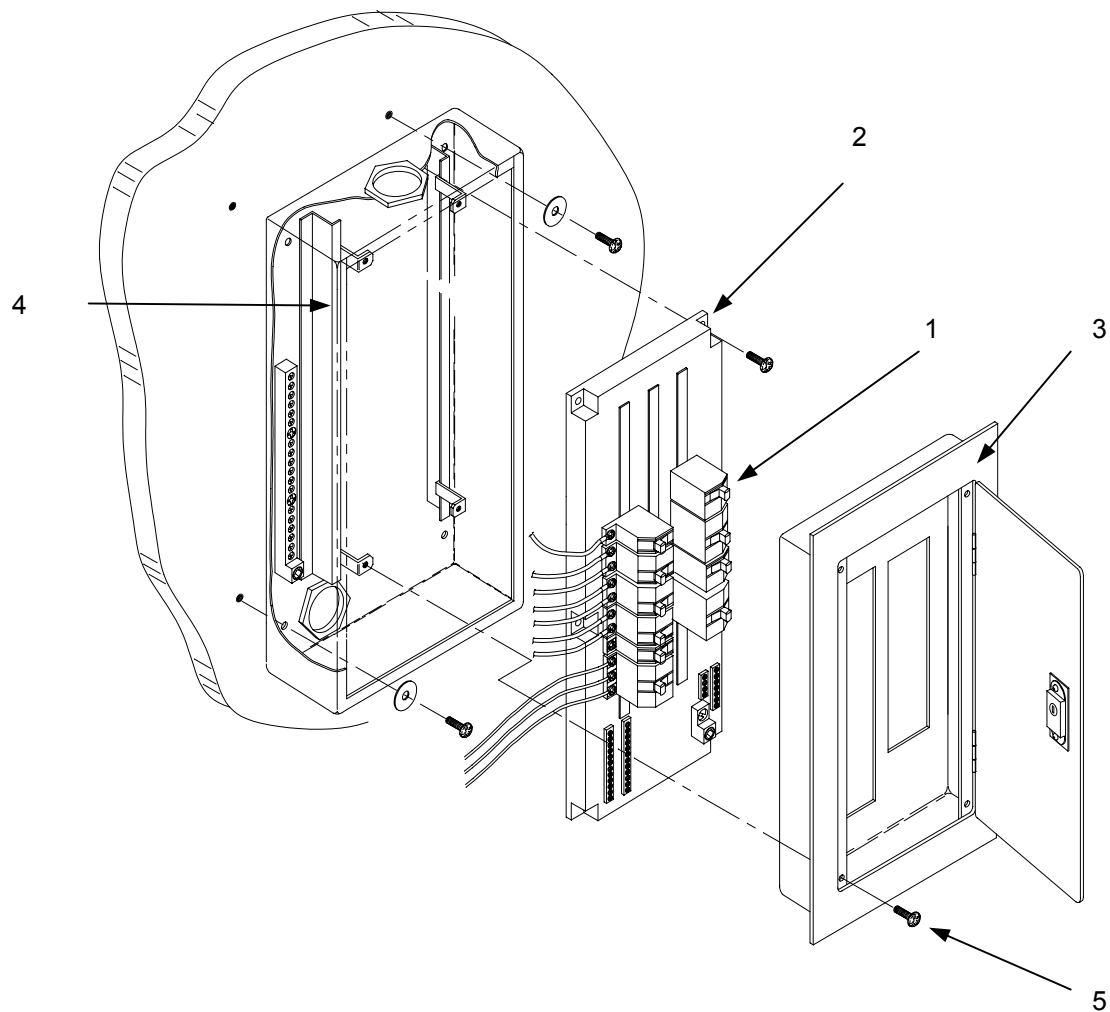



**WARNING**

This equipment operates at high voltage. Use extreme caution during test procedure. Touching a live wire can cause serious injury or death. Only MOS 51R, 52C, 52D, 52G or a qualified Civilian must perform this procedure.

10. Connect the 100 AMP power supply cables to the J1 and J2 connectors on the power entry panel.
11. Place all circuit breakers into the **ON** position as required.

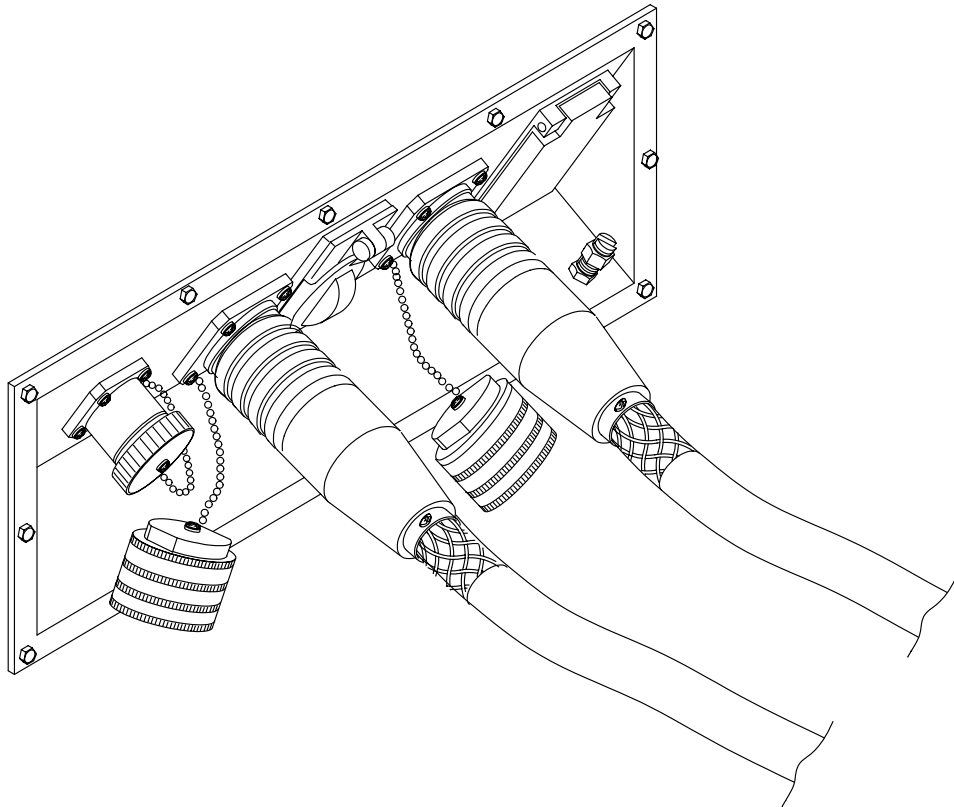

**END OF WORK PACKAGE**

THIS PAGE INTENTIONALLY LEFT BLANK

**DIRECT SUPPORT MAINTENANCE  
CONTAINERIZED SELF SERVICE LAUNDRY  
NSN 3510-01-485-0457  
FLUORESCENT LIGHTS  
TEST, REPLACE**

**INITIAL SETUP:****Equipment Condition**

CSSL not in operation

**Materials/Parts**

Wiping Rags (WP 0070 00, Table 1, Item 1)  
Tape, elec. Ins. (WP 0070, Table 1, Item 13)  
Tags, marking (WP 0070, Table 1, Item 8)  
Light, Fluorescent (WP 0070, Table 1, Item 2)  
Ballast (WP 0048, Fig. 5, Item 2)

**Tools and Special Tools**

Tool Kit, Electrical Equipment (WP 0042 Table 2  
Item 3).

**Personnel Required**

Two



**WARNING**

This equipment operates at high voltages. Use extreme caution during test procedure. Touching a live wire can cause serious injury or death. Only MOS 51R, 52C, 52D, 52G or a qualified civilian must perform this procedure.

**TEST**

1. Isolate the electrical malfunction of an interior fluorescent light.
2. Use Work Package 0027 00, Procedure 2, in the Direct Support Troubleshooting Procedures.

**REPLACE****Light.**

1. Place circuit breaker #1 in the right side power distribution panel to **OFF**.
2. Remove the dust cover **(1)** from the light fixture **(2)** by releasing the retainer clips **(3)**.
3. Pull the insulators **(4)** from the light bulb sockets **(5)** and turn the bulbs **(6)** to remove them.
4. Loosen the inner reflector retainers **(7)** and remove the reflector **(8)**.
5. Remove fixture **(2)** from the ceiling studs **(9)** being careful not to damage or strip the wires **(10)** as they are pulled from the fixture.

**Ballast.**

1. Disconnect the wire nuts (11) and tag the wires (12) from the ballast (13).
2. Remove hardware (14) securing the ballast (13) to the fixture.
3. Remove the ballast (13).
4. Secure the new ballast to the fixture using the retained hardware (14).
5. Connect the ballast wires (12) with wire nuts (11) and tape the wire nuts with electrical tape.
6. Install the reflector (8) using the reflector retainers (7).
7. Install the fluorescent light bulbs (6) and the insulators (4).
8. Position the dust cover (1) on the fixture and secure it with the retainer clips (3).
9. Place Circuit Breaker #1 on Circuit Breaker Panel #1 to ON position.

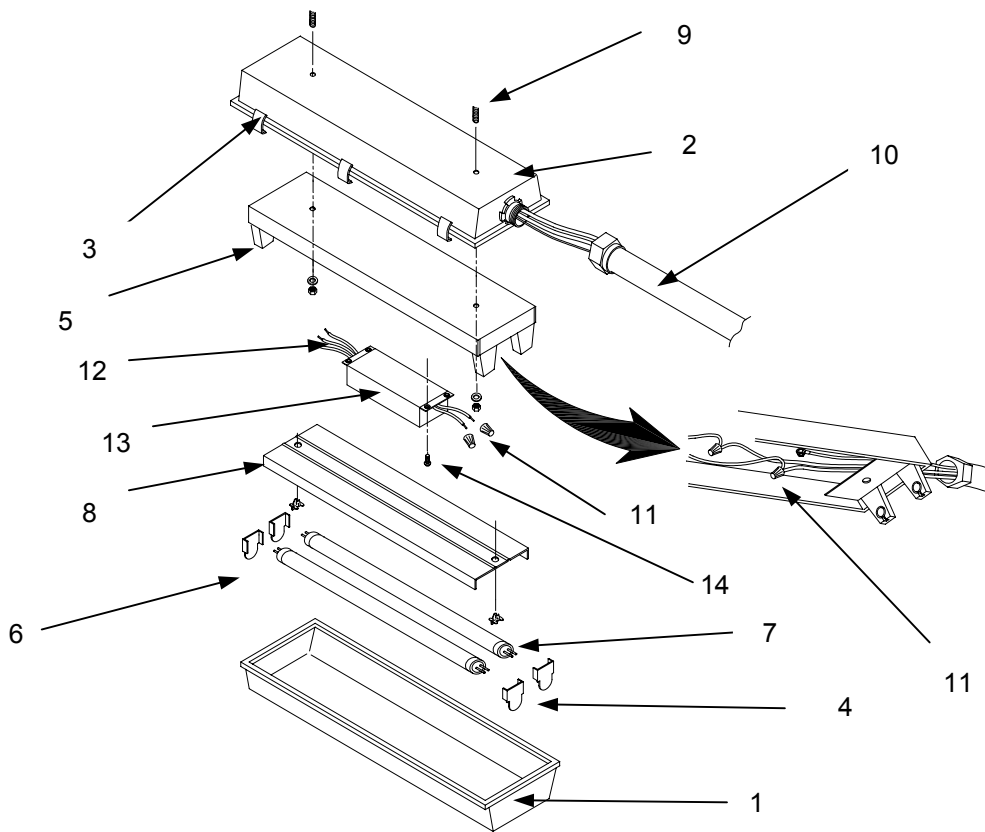

**END OF WORK PACKAGE**

---

**DIRECT SUPPORT MAINTENANCE  
CONTAINERIZED SELF SERVICE LAUNDRY (CSSL)  
NSN 3510-01-485-0457  
FRESHWATER PUMP AND INTERNAL FRESHWATER LINE  
REPLACE**

---

**INITIAL SETUP:****Equipment Condition**

CSSL not in operation

**Materials/Parts**

Wiping Rags (WP 0070 00, Table 1, Item 1)

Solder, Lead-Free (WP 0070, Table 1, Item 4)

Tape, Antiseize (WP 0070, Table 1, Item 3)

**Tools and Special Tools**

Tool Kit, Org. Maintenance, Common No.1

(WP 0042, Table 2, Item 2)

Pipe Wrench 18" (WP 0042, Table 2, Item 4)

Pipe Wrench 10" (WP 0042, Table 2, Item 5)

Tube Cutter. (WP 0042, Table 2, Item 6)

**Personnel Required**

Two



---

**WARNING**

---

This equipment operates at high voltages. Use extreme caution during test procedure. Touching a live wire can cause serious injury or death. Only MOS 51R, 52C, 52D, 52G or a qualified civilian must perform this procedure.

**REPLACE**

1. Before replacing the freshwater pump **(1)** disconnect the 2" freshwater hose from the freshwater input panel.
2. Connect a garden hose to the fitting at the end of the main supply line **(2)** (located behind washer/dryer #6) and open the ball valve **(3)**.
3. Remove the pressure switch **(4)** as described in work package 0034 00.
4. After removing the pressure switch, disconnect the 1" hex union fitting **(5)** and disconnect the 1 ½" hex union on the supply line **(6)**.
5. Remove the mounting bolts **(7)**, lock washers **(8)**, flat washers **(9)** and the worm clamp **(10)** from the saddle **(11)**, while holding the pump **(1)** to the mounting plate **(12)** on the floor. Retain the hardware.
6. Remove the 1 1/2" straight pipe section **(13)** from the pump inlet port **(14)**. Retain the pipe section.
7. Remove the 1" pipe stem **(15)** with the attached pipe section from the priming and outlet port **(16)**.

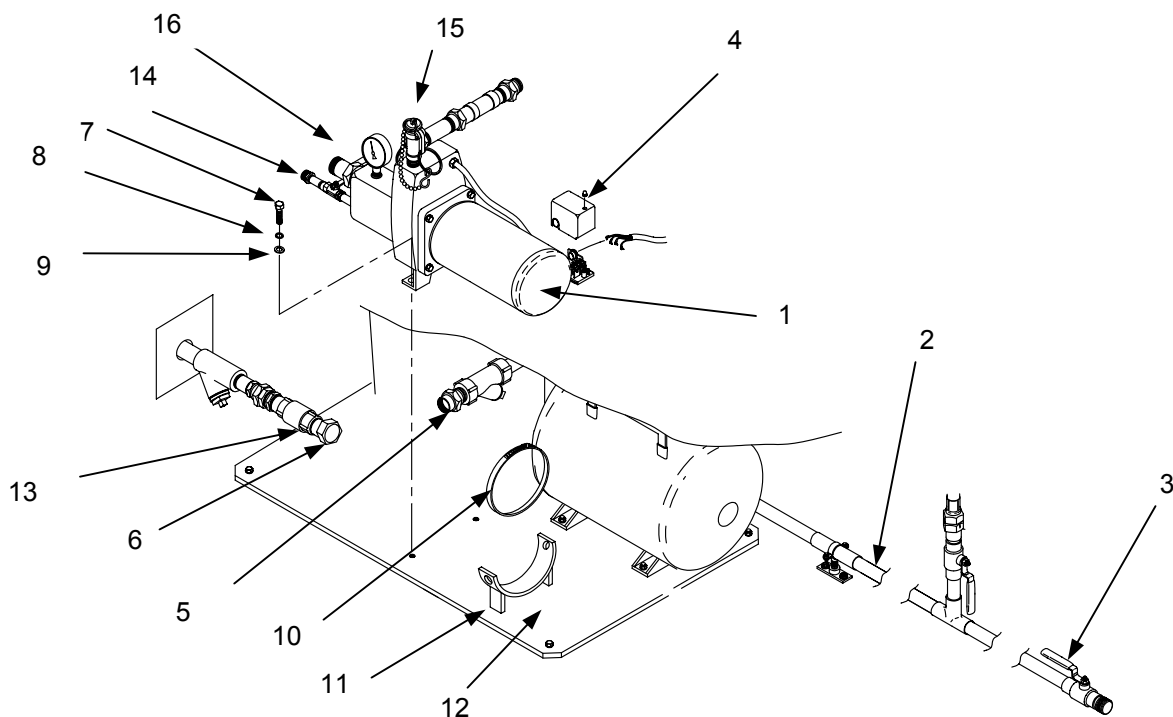

**WARNING**

The water pump is heavy. To avoid injuries, two persons are required to lift the pump.

8. Lift the pump (1) up and off the mounting plate (12).

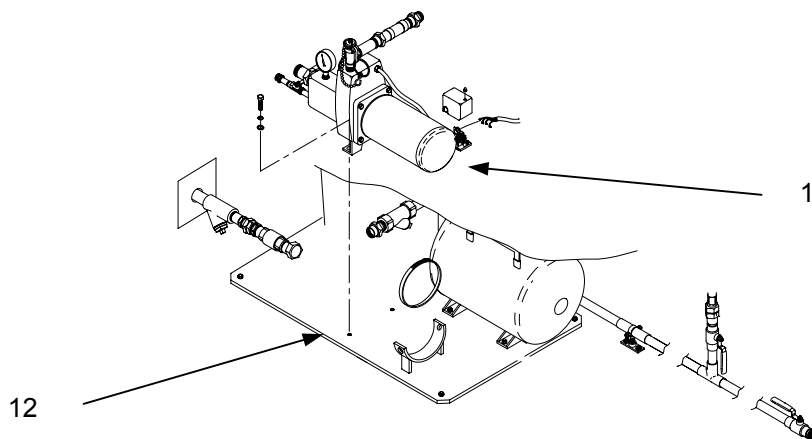

9. Install the items removed in the previous step to a new pump (1).
10. Apply antiseize to the reconnected copper joints.
11. Place the pump onto the mounting plate (2) by aligning the mounting bolts with the holes (3).
12. Reconnect the 1 ½" straight pipe section (5) to the pump inlet port (6).
13. Reconnect the 1" pipe stem (7) with the attached pipe section to the priming and outlet port (8). Install the mounting bolts, washers, and worm clamp (9).

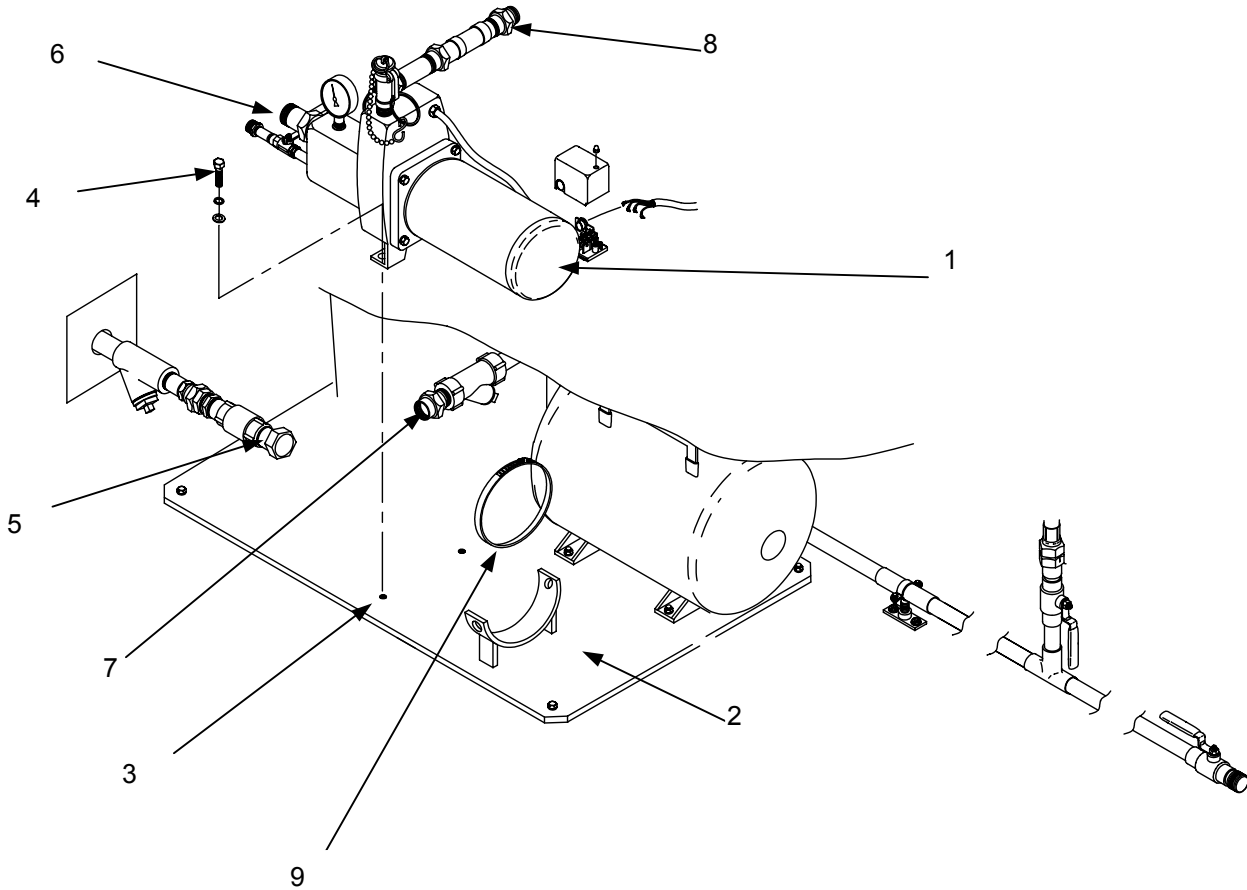

END OF WORK PACKAGE

THIS PAGE INTENTIONALLY LEFT BLANK



---

**DIRECT SUPPORT MAINTENANCE  
CONTAINERIZED SELF SERVICE LAUNDRY (CSSL)  
NSN 3510-01-485-0457  
PRESSURE TANK  
REPLACE**

---

**INITIAL SETUP:****Equipment Condition**

CSSL not in operation

**Materials/Parts**

Solder, Lead Free (WP70, Table 1, Item 4)

Wiping Rags (WP 0070, Table 1, Item 1)

Tape, Antiseize (WP 0070, Table 1, Item 3)

**Tools and Special Tools**

Tool Kit, Org. Maintenance, Common No. 1

(WP 0042, Table 2, Item 2)

**Personnel Required**

Two

---

**REPLACE**

1. Before replacing the pressure tank **(1)**, disconnect the freshwater hose from the freshwater input panel.
2. Connect a garden hose to the hose fitting **(2)** at the end of the freshwater line **(3)**.
3. Open the freshwater pump drain line ball valve **(4)**. Let the freshwater line drain.





---

**WARNING**

---

The pressure tank is heavy. To avoid injuries, two persons are required to lift the tank.

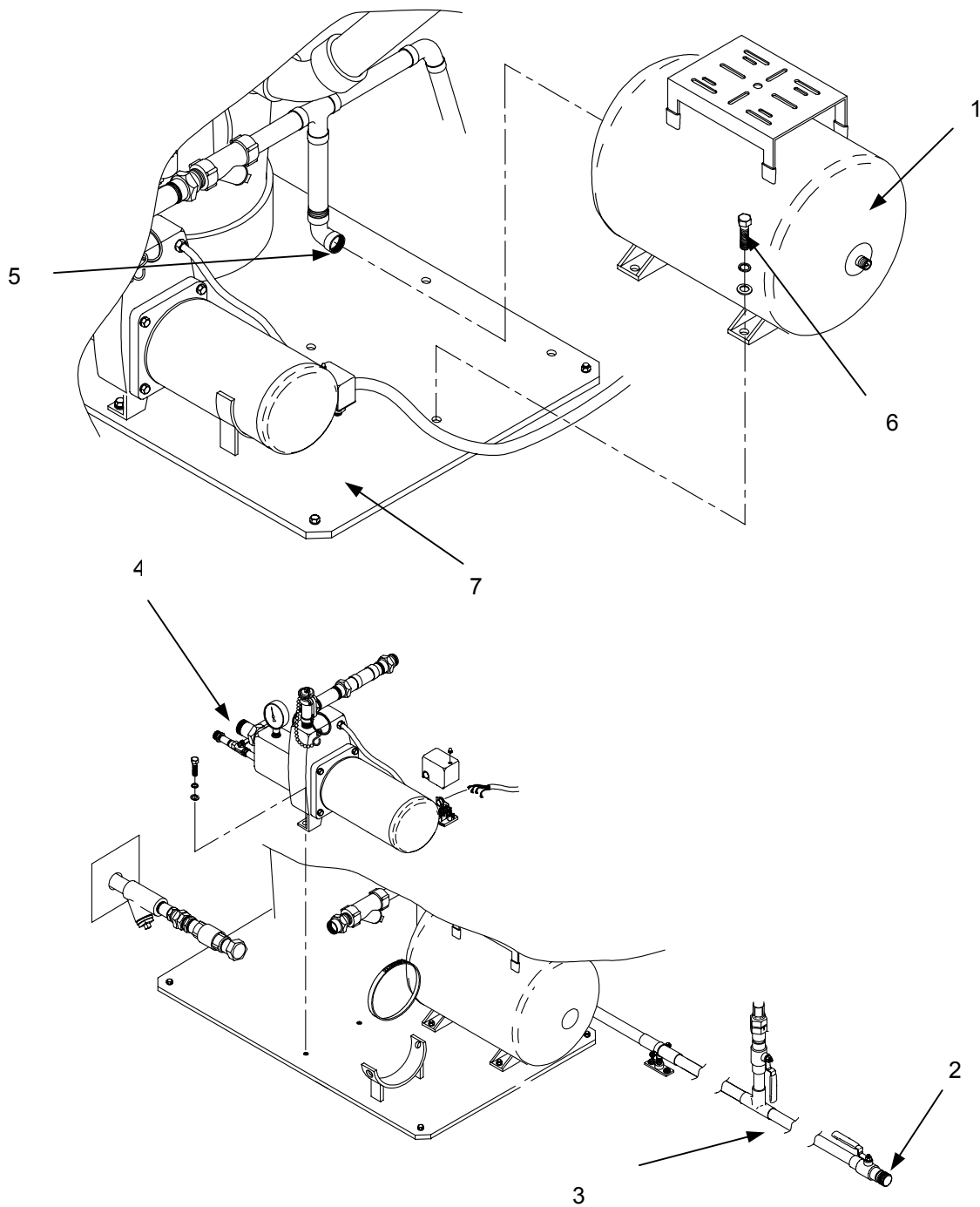
4. To remove the pressure tank **(1)** disconnect the water inlet line at the union fitting **(5)**. Remove four hex cap screws, lock washers, and flat washers **(6)** from the mounting plate **(7)**. Retain the hardware.
5. Lift the pressure tank up off the mounting plate **(7)**.
6. To install the pressure tank **(1)**, secure it to the mounting plate **(7)** with the four retained hex cap screws, lock washers, and flat washers.
7. Connect the water inlet line at the union fitting **(5)**.
8. Close the freshwater pump drain line ball valve **(4)**.
9. Disconnect the garden hose from the hose fitting **(2)**.
10. Connect the freshwater hose to the freshwater input panel.



END OF WORK PACKAGE

---

**DIRECT SUPPORT MAINTENANCE  
CONTAINERIZED SELF SERVICE LAUNDRY  
NSN 3510-01-485-0457  
PRESSURE SWITCH AND GAUGE  
REPLACE**

---

**INITIAL SETUP:****Equipment Condition**

CSSL not in operation (WP 0005)

**Materials/Parts**

Wiping Rags (WP 0070, Table 1, Item 1)

Tape, Antiseize (WP 0070, Table 1, Item 3)

**Tools and Special Tools**

Tool Kit General Mech., Automotive (WP 0042, Table 2, Item 1)

Pipe Wrench, 10" (WP 0042, Table 2, Item 5)

**Personnel Required**

Two



---

**WARNING**

---

This equipment operates at high voltages. Prior to repair or replacement of the switch, set circuit breaker #3 on right side power distribution panel to OFF, and disconnect the freshwater pump power cord. Touching a live wire can cause serious injury or death.

**REPLACE**

1. Before replacing the pressure switch **(1)** and gauge **(2)** disconnect the freshwater hose from the freshwater input panel.
2. Open the valve **(3)** on the drain line **(4)**.
3. Open the freshwater pump drain valve **(5)**.
4. Remove the pressure switch cover **(6)**. Disconnect and tag the wires **(7)**. Remove the nut **(8)** closest to the pump, and slide the wires out of the switch.
5. Remove the fitting **(9)** and pressure line from the bottom of the pressure switch.
6. Remove the nut securing the switch **(1)** to the pump housing, and remove the switch.
7. Remove the gauge **(2)** from the pump housing.

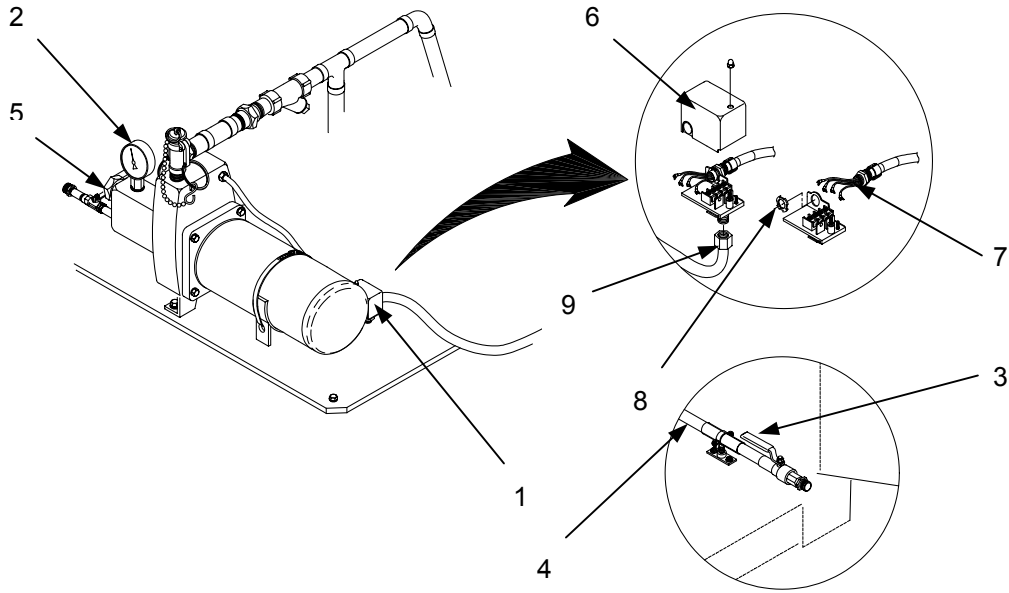

8. Using the retained hardware, mount the new pressure switch (1) to the pump housing.
9. Slide the wires (2) through the switch mounting plate (3). Install the nut (4) over the wires and secure the nut.
10. Re-connect the tagged wires (2) in proper order.
11. Reconnect the fitting (5) and pressure line to the bottom of the pressure switch (1).
12. Install the pressure switch cover (6).
13. Using anti-seize tape, install new pressure gauge (7) into the pump housing.

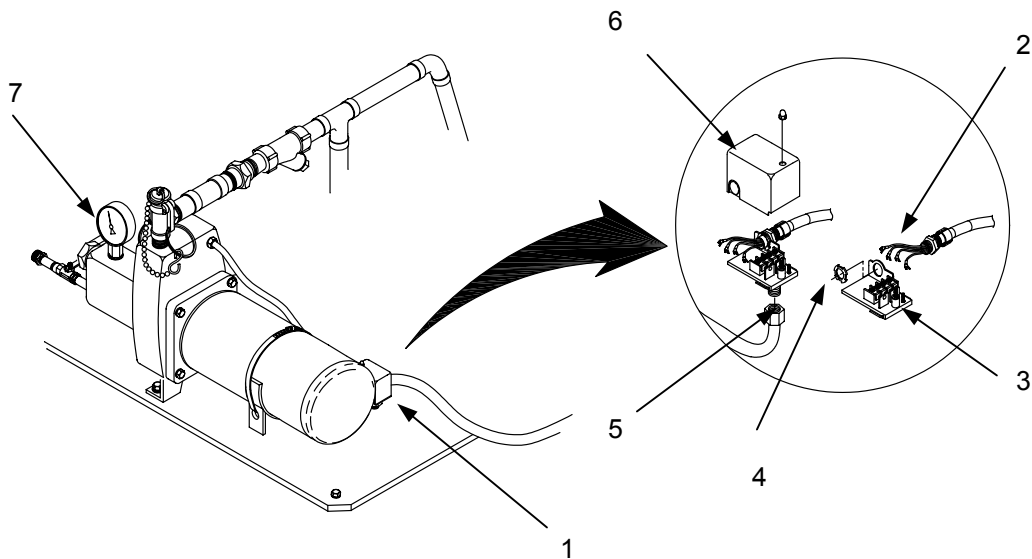

**END OF WORK PACKAGE**

---

**DIRECT SUPPORT MAINTENANCE  
CONTAINERIZED SELF SERVICE LAUNDRY (CSSL)  
NSN 3510-01-485-0457  
SUMP PUMP AND FLOAT SWITCH  
REPAIR, REPLACE**

---

**INITIAL SETUP:****Equipment Condition**

CSSL not in operation

**Materials/Parts**

Wiping Rags (WP 0070, Table 1, Item 1)

**Tools and Special Tools**

Tool Kit, General Mech. Automotive (WP 0042, Table 2, Item 1)

**Personnel Required**

Two



---

**WARNING**

---

This equipment operates at high voltage. Use extreme caution. Set circuit breaker #12 on the right side power distribution panel to OFF. Touching a live wire can cause serious injury or death.

**REPAIR****Sump Pump.**

1. Before repairing or replacing the sump pump, ensure that all the washers have completed their wash cycle. If necessary, drain the wastewater tank so that the water level is below the wastewater discharge pipe.
2. To repair the sump pump power cord, remove and install the pump as described below.
3. Replace the power cord as described in Work Package 0072 00, Figure 3, Power Cord Modification.

**REPLACE****Sump Pump.**

1. Loosen the screw on the front of the wire retainer bracket **(1)**.
2. Remove the four screws **(2)** from the wall plate **(3)** of the junction box. Remove the wall plate.
3. Tag and disconnect all wires from the sump pump cord **(4)** inside the junction box.
4. Pull the wires through the opening in the junction box.
5. Remove all cable ties from the sump pump cord **(4)**.
6. Slide the sump pump cord through the wall mounted cable bracket **(5)**.
7. Remove the hex bolts **(6)**, washers **(7)** and nuts **(8)** on the wastewater tank cover **(9)** and remove the cover.

8. Feed the sump pump cord through the opening (10) in the wastewater tank cover.
9. Remove the two hex bolts from the pump mounting flange (11) at the bottom of the sump pump discharge pipe (12).



**WARNING**

The sump pump is heavy. To avoid injuries, two persons are required to lift the sump pump.

10. Lift the pump (13) out of the wastewater tank.

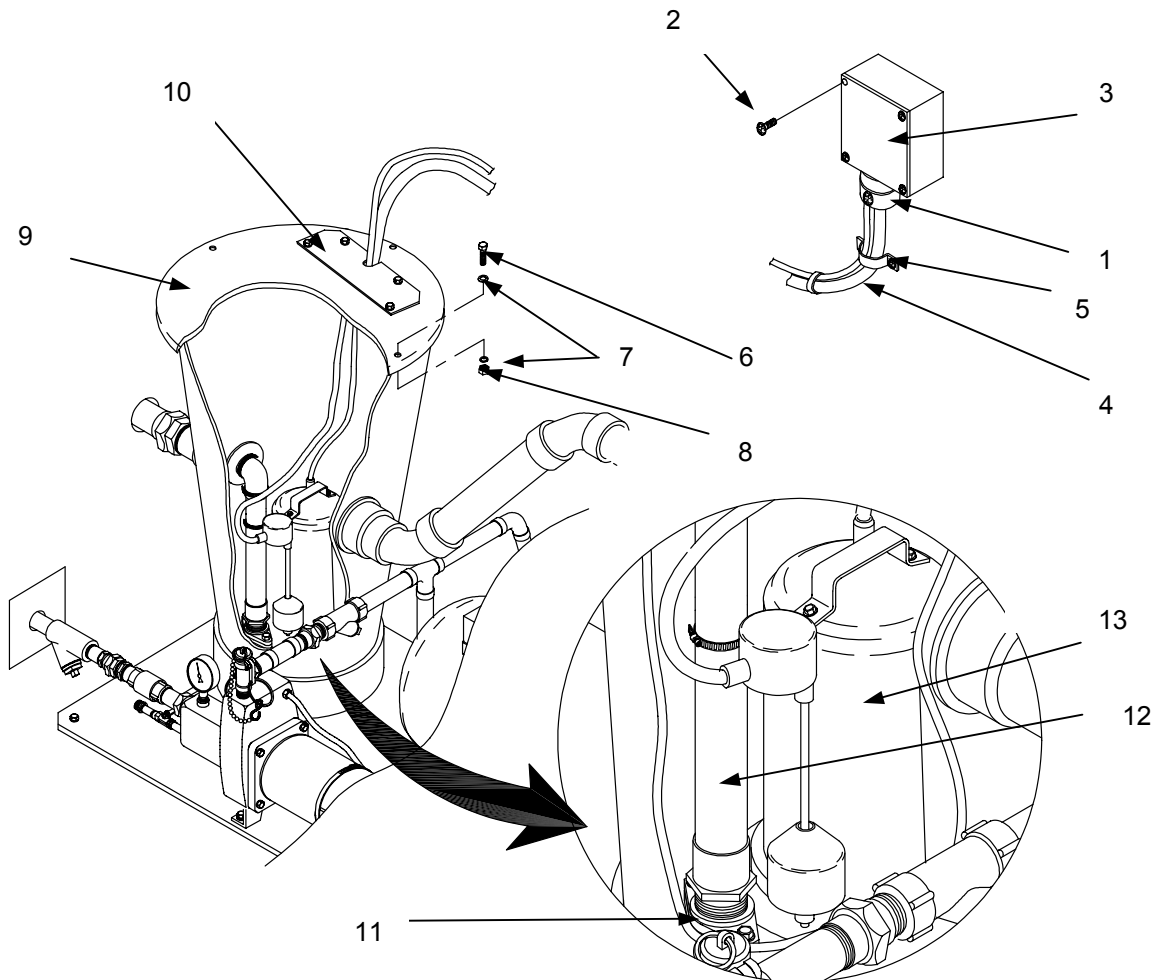



### **WARNING**

The sump pump is heavy. To avoid injuries, two persons are required to lift the sump pump.

11. Place the new sump pump **(13)** into the tank.
12. Place the gasket between the pump mounting flange **(11)** and the sump pump.
13. Install the two hex bolts into the sump pump mounting flange **(11)**.
14. Feed the sump pump cord **(4)** through opening **(10)** in the wastewater tank cover.
15. Place the wastewater tank cover **(9)** into position and re-install the hardware **(6)**, **(7)**, and **(8)** to secure the cover.
16. Thread the cords up through the wall mounted cable bracket **(5)** and into the junction box.
17. Re-connect the power cord **(4)** inside the junction box on the side wall.
18. Re-install the junction box wall plate **(3)** using the retained hardware **(2)**.
19. Tighten the screw on the front of the wire retainer bracket **(1)**.

#### **Float Switch.**

1. Loosen the screw on the front of the wire retainer bracket **(1)**.
2. Remove the four screws **(2)** from the wall plate **(3)** of the junction box. Remove the wall plate.
3. Tag and disconnect all wires from the float switch cord **(4)** inside the junction box.
4. Pull the wires through the opening in the junction box.
5. Remove all cable ties from the float switch cord **(4)**.
6. Slide the float switch cord through the wall mounted cable bracket **(5)**.
7. Remove the hex bolts **(6)**, washers **(7)** and nuts **(8)** on the wastewater tank cover **(9)** and remove the cover.
8. Feed the float switch cord through the opening **(10)** in the wastewater tank cover.
9. Remove the worm gear clamp **(11)** securing the float switch **(12)** to the sump pump discharge pipe **(13)**.
10. Remove the float switch **(12)** from the wastewater tank.

11. Place the new float switch (12) into the tank.
12. Install the worm gear clamp (11) securing the float switch (12) to the sump pump discharge pipe (13).
13. Install the two hex bolts into the sump pump mounting flange (14).
14. Feed the float switch cord (4) through opening (10) in the wastewater tank cover.
15. Place the wastewater tank cover (9) into position and re-install the hardware (6), (7) and (8) to secure the cover.
16. Thread the float switch cord up through the wall mounted cable bracket (5) and into the junction box.
17. Re-connect the float switch cord (4) inside the junction box on the side wall.
18. Re-install the junction box wall plate (3) using the retained hardware (2).
19. Tighten the screw on the front of the wire retainer bracket (1).

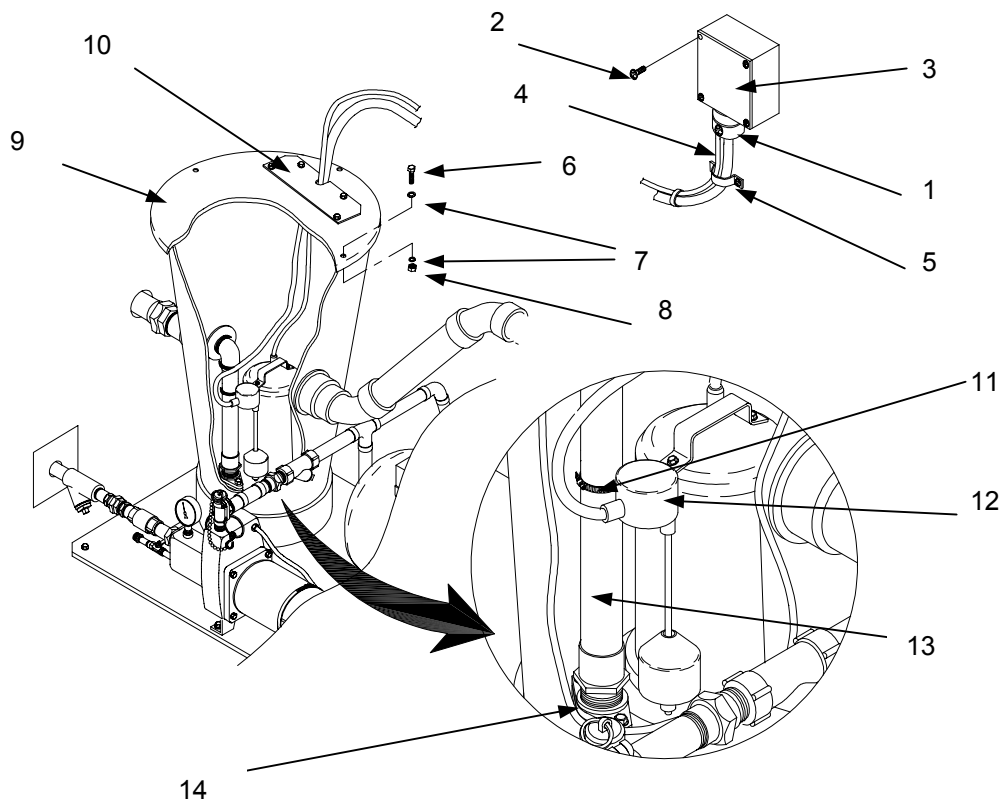

**END OF WORK PACKAGE**



---

**DIRECT SUPPORT MAINTENANCE  
CONTAINERIZED SELF SERVICE LAUNDRY (CSSL)  
NSN 3510-01-485-0457  
WASTEWATER PVC PIPES  
REPAIR**

---

**INITIAL SETUP:****Equipment Condition**

CSSL not in operation

**Materials/Parts**

Cement, PVC Piping (WP 0070, Table 1, Item 6)

Wiping Rags (WP 0070, Table 1, Item 1)

Cleaner, PVC Piping (WP 0070, Table 1, Item 7)

**Tools and Special Tools**

Tool Kit, Gen. Mech. Automotive (WP 0042, Table 2, Item 1)

Hacksaw (WP 0042, Table 2, Item 7)

Hacksaw Blade (WP 0042, Table 2, Item 8)

**Personnel Required**

One



---

**WARNING**

---

Ensure that wastewater is properly disposed of, either through an approved municipal sewage system, or collected using a 3,000 gallon tank, with subsequent evacuation by tanker. Keep wastewater hoses away from freshwater hoses and any freshwater supply in the vicinity. Serious health problems may result from water contamination.

**REPAIR**

1. Before repairing the wastewater PVC Pipes, ensure that all the washers have completed their wash cycle. If necessary, drain the wastewater tank **(1)** so that the water level is below the PVC pipe inlet **(2)**.
2. Before repairing any portion of the wastewater PVC pipes, open the cleanout fitting **(3)** at the end of the line, and let the line drain. Repair any leaks or malfunctioning components of the line as described below.
3. Repair a leaking or damaged PVC pipe or component such as an elbow fitting **(4)**, clean out fitting **(3)**, an adapter fitting **(5)**, a bushing **(6)**, or a Tee **(7)** by cutting out the leaking or damaged section and replacing it with a similar new section.
4. Clean the ends of both connecting sections with all-purpose cleaner, and cement the sections together. Follow the product instructions for the use of the all-purpose cement.

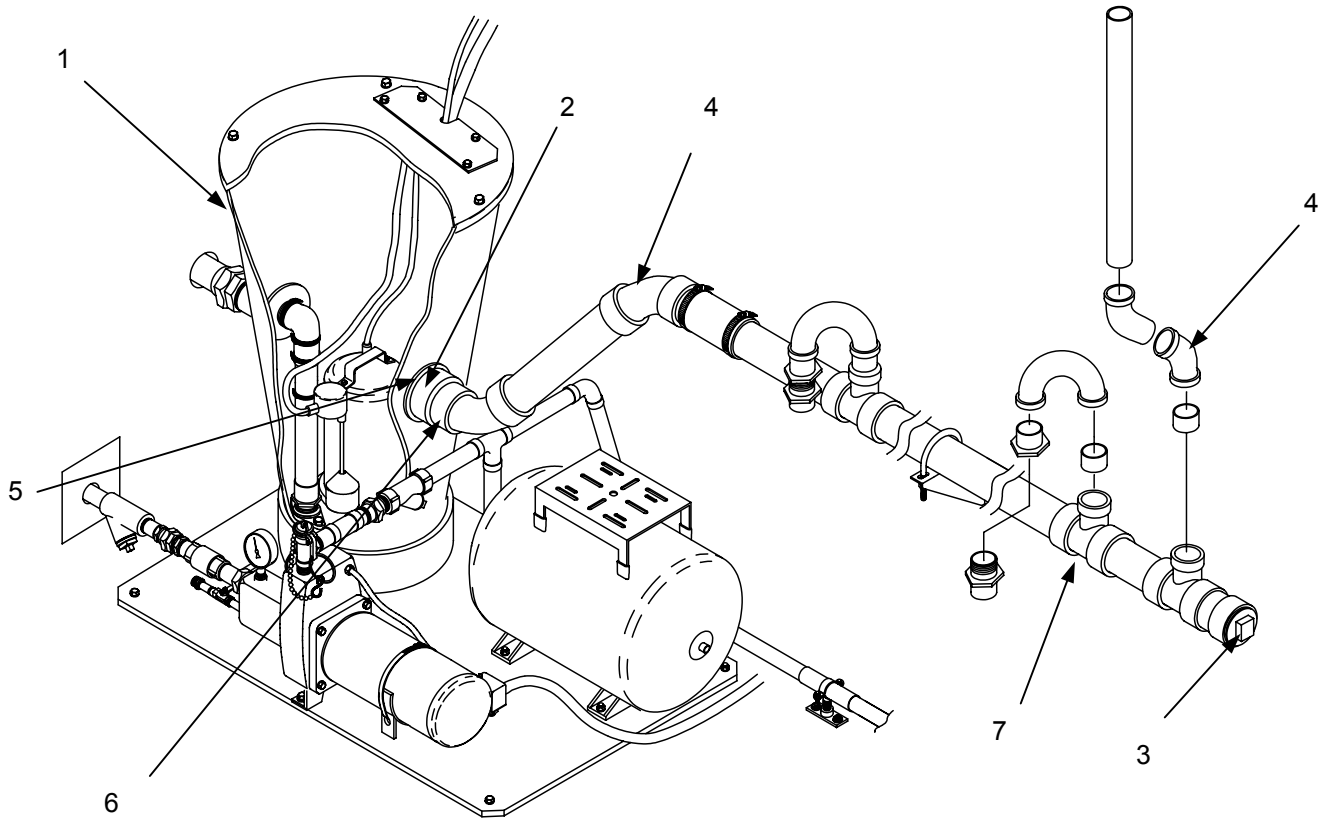

END OF WORK PACKAGE

---

**DIRECT SUPPORT MAINTENANCE  
CONTAINERIZED SELF SERVICE LAUNDRY (CSSL)  
NSN 3510-01-485-0457  
WASHER/DRYER  
REPAIR, REPLACE**

---

**INITIAL SETUP:****Equipment Condition**

CSSL not in operation

**Materials/Parts**

Wiping Rags (WP 0070, Table 1, Item 1)

V-belt, Pump (WP 0070 Table 1, Item 18)

V-belt, Drive (WP 0070, Table 1, Item 17)

**Tools and Special Tools**Tool Kit, Org. Maintenance Common No.1  
(WP0042, Table 2, Item 2)**Personnel Required**

Two



---

**WARNING**

---

This equipment operates at high voltages. Use extreme caution. Observe all warnings, and follow all safety procedures. Only MOS 51R, 52C, 52D, 52G or a qualified civilian must perform this procedure. Touching a live wire can cause serious injury or death.

**REPAIR****Water Pump Belt.**

1. Lay the washer on its front for access.
2. Loosen three screws **(1)** from the bottom of the base securing the pump.
3. Slide the pump to slacken the belt.
4. Remove the broken belt.
6. Place a new belt over the motor pulley **(2)** and pump pulley **(3)**.
7. Slide the pump back to tighten the belt.
8. Secure the three screws **(1)**.
9. Grasp the belt at its mid point and squeeze with moderate pressure. There should be  $\frac{1}{4}$  inch clearance between the inside surfaces of the belt.
10. Adjust the belt by re-positioning the pump as necessary.

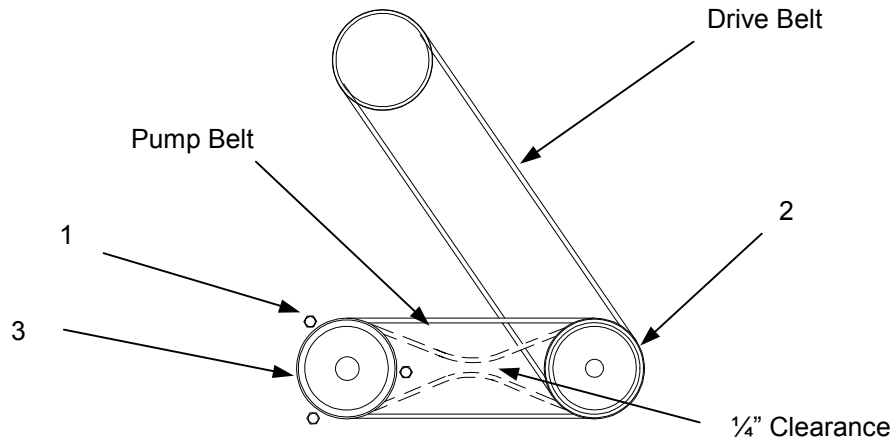

**Washer Drive Belt.**

1. Lay the washer on its front for access. Loosen the water pump and remove the water pump belt as described above.
2. Remove the broken drive belt **(1)** from the drive **(2)** and drum pulleys **(3)**.
3. Move the motor on its track to obtain sufficient slack.
4. Place a new belt on the drive **(2)** and drum **(3)** pulleys.
5. Adjust the motor on its track to tighten the drive belt.
6. Tighten the motor.
7. Re-install the water pump belt **(4)** and adjust as described above.
8. Tighten the water pump after adjusting the pump belt.

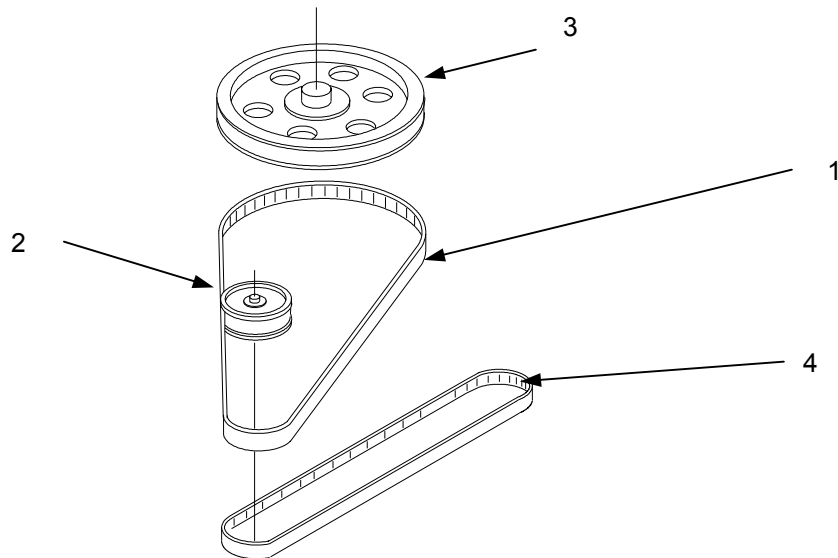

**REPLACE****Washer Removal.**

1. Prior to replacing a washer/dryer, open the side double service doors on the container to gain access to the rear of the washer/dryer.
2. Ensure that the machine to be replaced is empty of water and clothing items.
3. Turn OFF the appropriate circuit breaker for the machine to be replaced.
4. Turn off the water supply valve **(1)** for the machine to be replaced.
5. Unplug the twist lock connector **(2)** from the overhead raceway **(3)**.
6. Remove and retain the hardware **(4)** securing the front panel **(5)**.
7. Remove and retain the bolt **(6)** securing the washer to the frame **(7)**.
8. Slide the washer forward until it reaches the front stops on the frame **(7)**.
9. Remove and retain the wastewater hose **(8)** and clamp **(9)**.
10. Reach over the top of the washer and disconnect the 50 pin connector **(10)**.
11. Disconnect the "Y" water connection **(11)** on the back of the washer.
12. Lift the washer up over the stop and remove it from the frame.

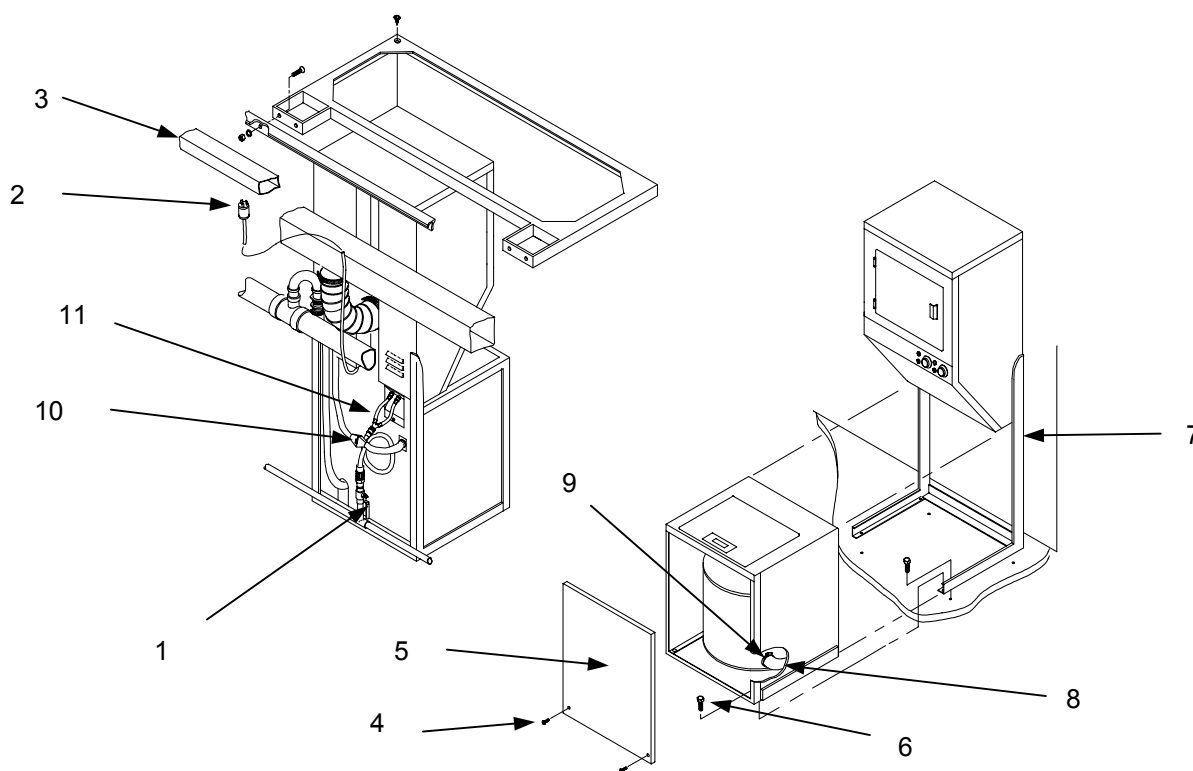

**Dryer Removal.**

1. Remove and retain the four hex head bolts (1) securing the dryer frame to the floor.
2. Remove and retain the worm gear clamp (2) securing the flexible hose (3) to the duct (4).
3. Remove and retain the sheet metal screw (5) securing the top frame (6) to the dryer.
4. Remove and retain the screws (7) washers (8) and nuts (9) securing the top frame (6) to the wall mount (10).
5. Remove the top frame.
6. Slide the dryer and frame out.
7. Remove and retain the power cord (11).

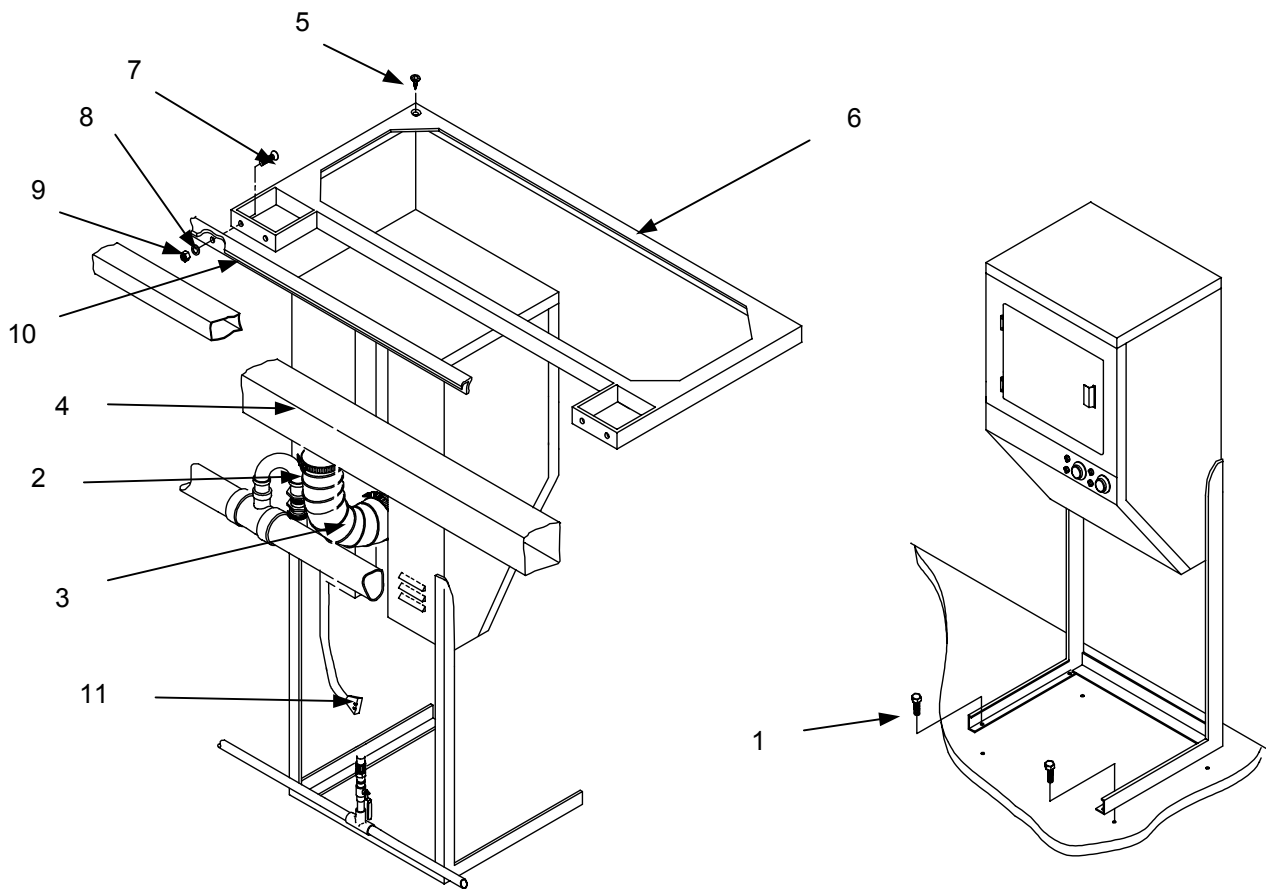

### Washer Replace.

1. Prior to installation of a new washer/dryer, remove all packing materials in accordance with manufacturers instructions.
2. Install the sheet metal adapter (1) on the new dryer using the retained clamp.
3. Remove the ground strip (2). From the electrical connection panel.
4. Install the power cord (3).
5. Connect the wastewater hose (4). Using the retained clamp.
6. Remove the four leveling feet (5).

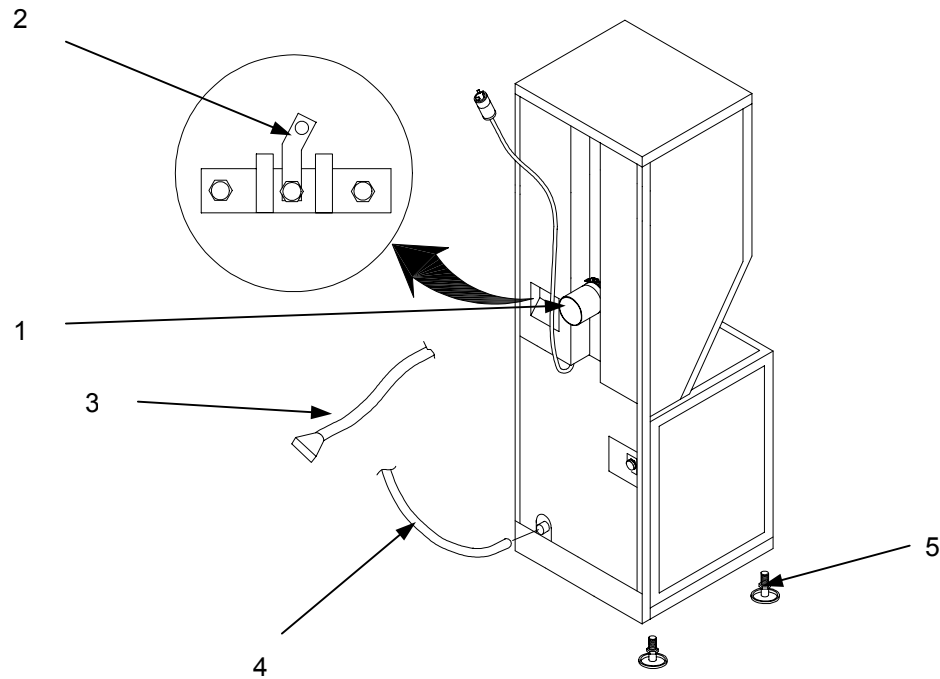

7. Slide the assembled washer/dryer into position on the floor.
8. Remove the front panel (6) of the washer. Retain the securing hardware (15).
9. Slide the washer unit over the stops (7) and out of the frame to gain access to the mounting holes (8).
10. Align the dryer and frame assembly over the mounting holes in the floor (9).
11. Install the retained bolts (10) to secure the dryer and frame assembly to the floor.

12. Connect the water supply hose to the water line (11).
13. Slide the washer part way in and feed the wastewater hose (12) through from the back to the front of the washer.
14. Connect the wastewater hose (12) using the retained clamp (13).
15. Push the washer all the way back into the frame.
16. Bolt the washer to the floor using the retained bolt (14) in the right front corner of the frame.
17. Secure the front panel (6) to the washer using the retained screws (15).
18. Place the top frame (16) on top of the washer dryer assembly.
19. Secure the top frame to the dryer (17) using the retained hardware (18).
20. Secure the frame to the wall mount (19). Using the retained hardware.
21. Connect the 15 pin electrical connector (20).
22. Plug the power cord (21) into the overhead raceway (22).

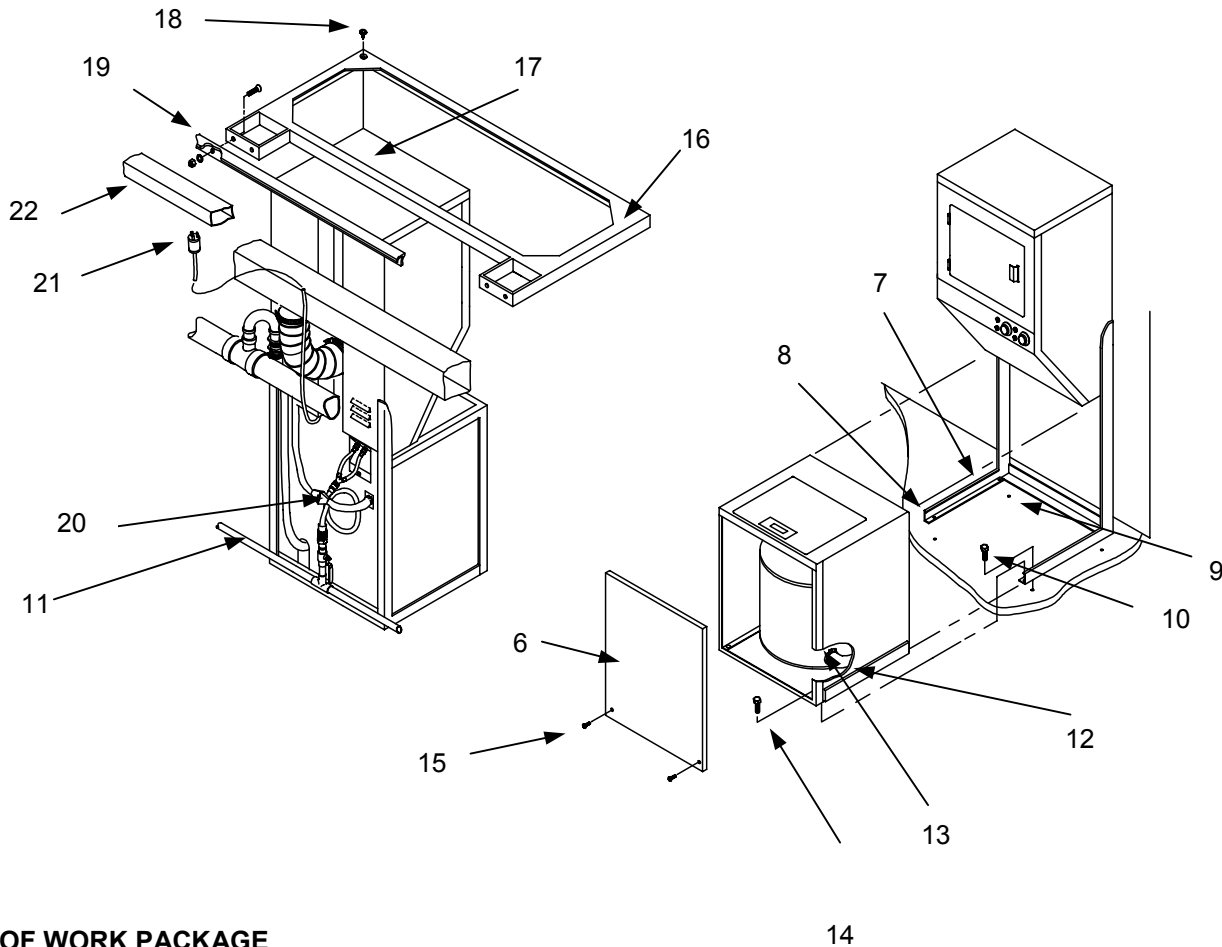

END OF WORK PACKAGE



---

**DIRECT SUPPORT MAINTENANCE  
CONTAINERIZED SELF SERVICE LAUNDRY (CSSL)  
NSN 3510-01-485-0457  
VENT FAN  
TEST, REPAIR, REPLACE**

---

**INITIAL SETUP:****Equipment Condition**

CSSL not in operation

**Materials/Parts**

Wiping Rags (WP 0070, Table 1, Item 1)

**Tools and Special Tools**

Tool Kit, Org. Maint. Common No.1

(WP 0042, Table 2, Item 2)

**Personnel Required**

Two



---

**WARNING**

---

This equipment operates at high voltages. Use extreme caution during test procedure. Touching a live wire can cause serious injury or death. Only MOS 51R, 52C, 52D, 52G or a qualified civilian must perform this procedure.

**TEST**

1. Turn the vent fan switch **(1)** ON.
2. Check that circuit breaker #8 in the right side power distribution panel **(2)** is ON.
3. Check for the 120 VAC power from outside the utility wall.
4. Remove the external fan cover **(3)** by removing the hardware **(4)**.
5. Remove the two screws **(5)** from the plate **(6)** and grommet **(7)** on the rear of the motor housing.
6. Check for power using a multimeter, and check for power from the ground to the stud **(8)**.

**REPAIR**

1. Before removing the vent fan **(9)**, set circuit breaker #8 in the right side power distribution panel **(2)** to **OFF**.
2. Disconnect and tag all wires even if the wires are already tagged. Pull the wires and conduit **(10)** away from the fan motor.
3. Remove the internal fan cover **(11)** by removing the hardware **(12)**.
4. Remove the fan blades **(13)** from the fan motor by loosening the setscrew **(14)**.

5. Remove and retain the motor ground wire **(15)** from the motor body.
6. Remove the front and rear motor clamps **(16)** by loosening the bolts **(18)**.
7. Lift and remove the motor **(9)** from the motor mount **(17)**.

## REPLACE

1. Place the new motor **(9)** into the motor mount **(17)**.
2. Re-attach the retained ground wire **(15)** to the fan motor and frame.
3. Replace the motor mount clamps **(16)** on the rear and front of the fan motor. Tighten the bolts **(18)**.
4. Replace the fan blade **(13)** and tighten the set screw **(14)**.
5. Feed the wires **(10)** back into the motor housing and seat the conduit in the mounting hole.
6. Reconnect the tagged wires.
7. Replace the grommet **(7)**, plate **(6)** and screws **(5)** on the motor **(9)**.
8. Turn circuit breaker #8 in the right side power distribution panel to **ON**.
9. Perform the test procedures above.
10. Reinstall the plate and grommet, using the retained screws.
11. Reinstall the external vent fan **(3)** cover using the retained screws.
12. Reinstall the internal vent fan cover **(11)** using the retained screws.

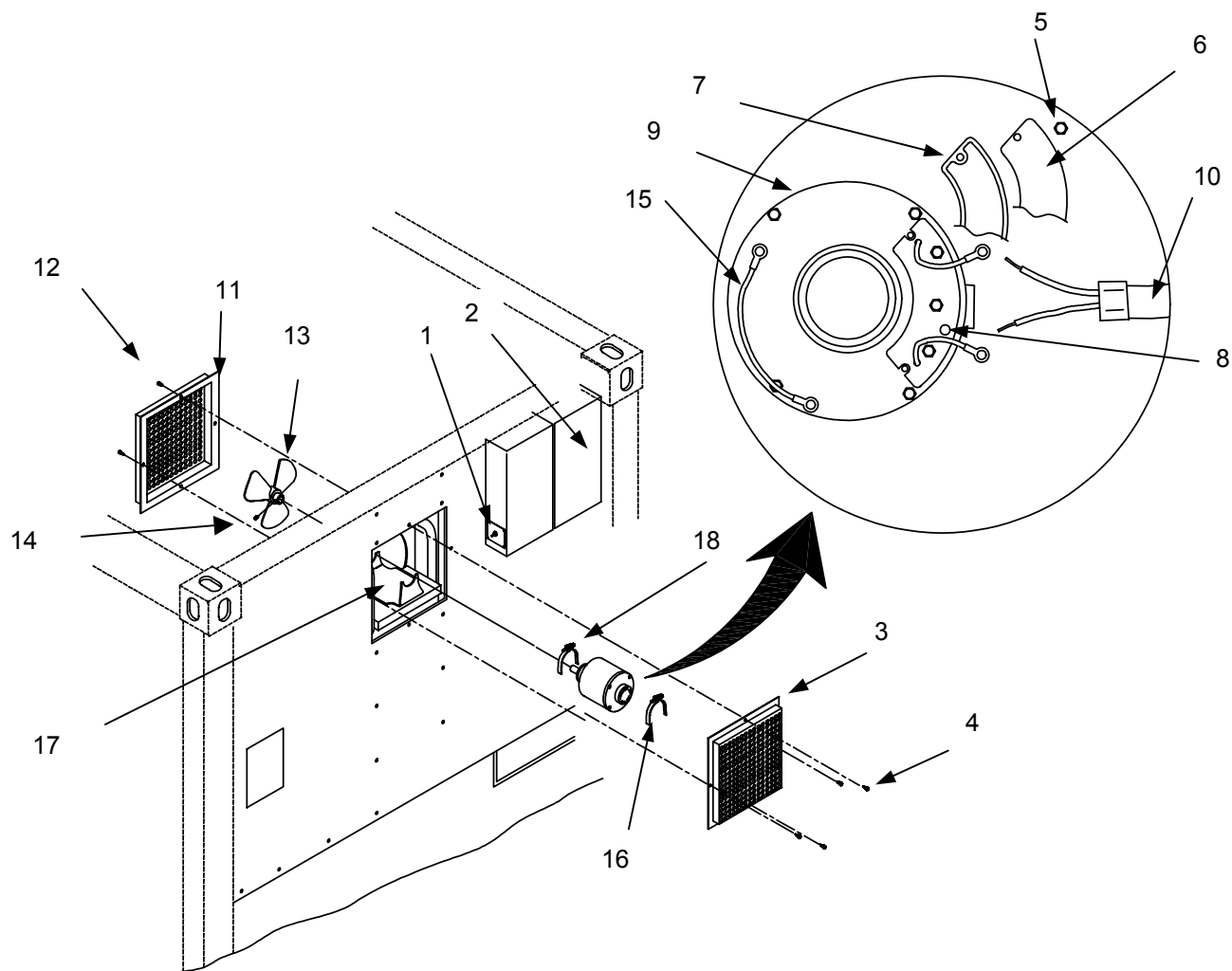

THIS PAGE INTENTIONALLY LEFT BLANK

---

**DIRECT SUPPORT MAINTENANCE  
CONTAINERIZED SELF SERVICE LAUNDRY (CSSL)  
NSN 3510-01-485-0457  
SPACE HEATER  
TEST, SERVICE, REPLACE**

---

**INITIAL SETUP:****Equipment Condition**

CSSL not in operation, power disconnected

**Materials/Parts**

Wiping Rags (WP 0070, Table 1, Item 1)

**Tools and Special Tools**

Tool Kit, Electronic Equipment (WP 0042, Table 2, Item 3)

**Personnel Required**

Two



---

**WARNING**

---

This equipment operates at high voltages. Use extreme caution during test procedure. Touching a live wire can cause serious injury or death. Only MOS 51R, 52C, 52D, 52G or a qualified civilian must perform this procedure.



---

**WARNING**

---

The space heater is heavy. To avoid injuries, two persons must lift the heater.

**TEST**

1. Isolate the electrical malfunction of the space heater.
2. See Work Package 0027 00, Procedure 2, Internal Component Power Loss, Direct Support Troubleshooting Procedures.

**SERVICE**

1. Before servicing the space heater **(1)**, set circuit breaker #15 on the right side power distribution panel to **OFF**.
2. Disconnect and tag the power cord wires **(2)** from inside the heater.
3. Reach in back of the heater and remove the grill **(3)**.
4. Remove any debris.

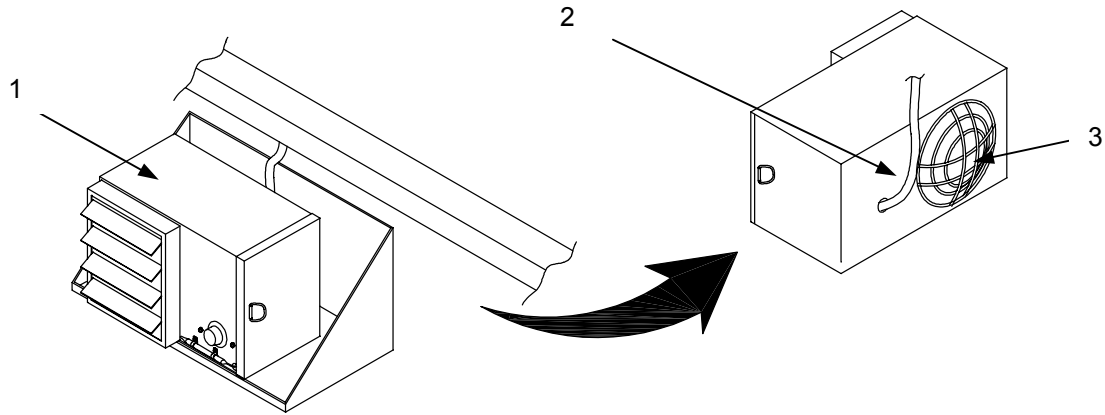

**REPLACE**

1. To remove the space heater (1) from the mount (2), remove two pan head screws (3) and washers (4) securing the space heater to the bottom of the mount (2) and one pan head screw (5) and washer (6) securing it to the side of the mount. Retain the screws and washers.
2. Disconnect and tag the power cord wires (7) from inside the heater.
3. Remove the lock nut (8) securing the conduit (9) to the heater body.
4. Remove the heater (1) from the mount (2).

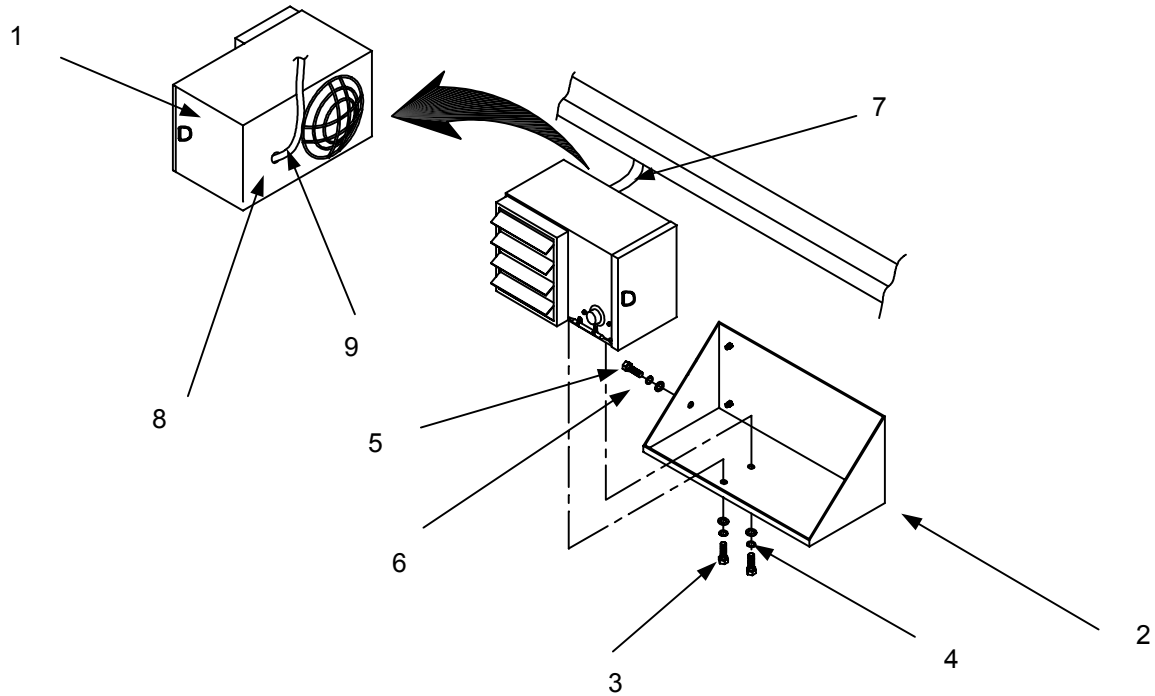

5. Place the new space heater (1) on the mount (2).
6. Install two pan head screws (3) and washers (4) securing the heater to the bottom of the mount.
7. Install one pan head screw (5) and washer (6) securing the heater to the side of the mount.
8. Replace the wires (7) through the heater body and reattach them.
9. Secure the conduit (8) with the retained lock nut (9).
10. Reset circuit breaker #15 on the right side power distribution panel to **ON**.

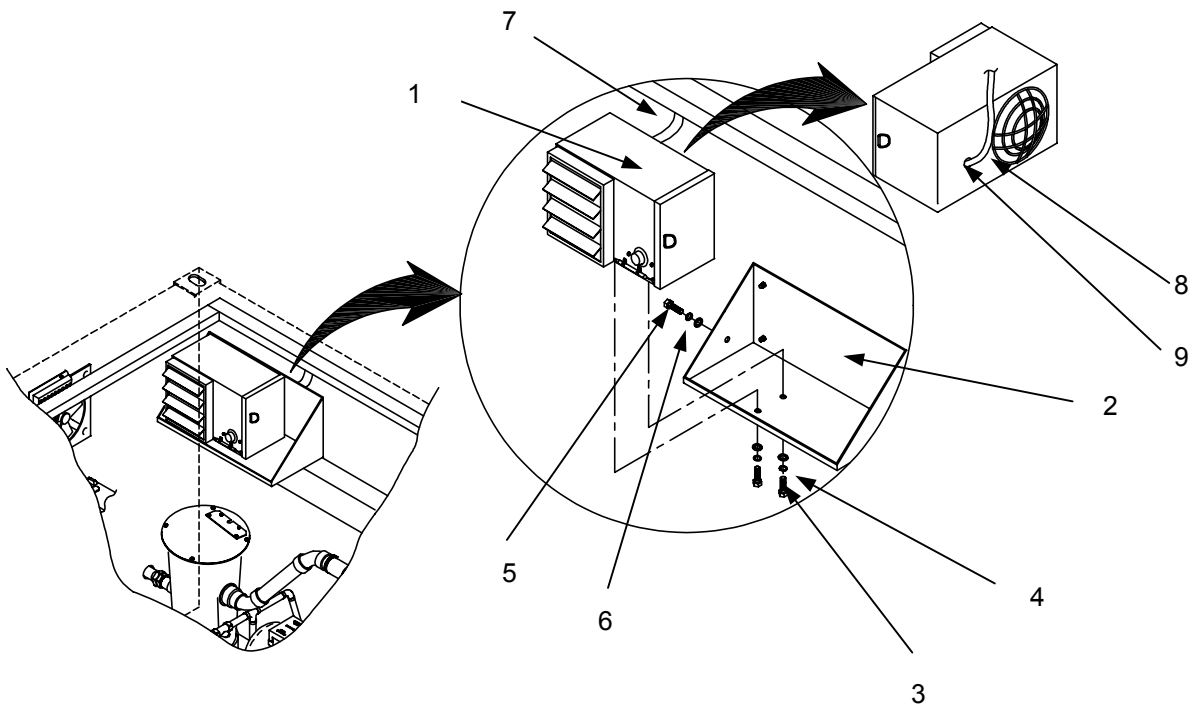

END OF WORK PACKAGE

THIS PAGE INTENTIONALLY LEFT BLANK



**TM 10-3510-224-13&P**

**CHAPTER 7  
SUPPORTING INFORMATION  
FOR THE  
CONTAINERIZED SELF SERVICE LAUNDRY  
(CSSL)  
MODEL B**

THIS PAGE INTENTIONALLY LEFT BLANK

**CONTAINERIZED SELF SERVICE LAUNDRY**  
**NSN 3510-01-485-0457**  
**REFERENCES**

**Scope.**

This work package lists pamphlets, field manuals, forms, technical manuals and miscellaneous publications referenced in this manual or otherwise relevant to the employment of the CSSL Model B.

**Pamphlets.**

Functional Users Manual for the  
 Army Maintenance Management System (TAMMS)..... DA Pam 738-750

**Field Manuals.**

Basic Cold Weather Manual ..... FM 31-70  
 First Aid for Soldiers ..... FM 21-11  
 Mountain Operations ..... FM 3-97.6  
 Northern Operations ..... FM 31-71  
 General Fabric Repair..... FM 10-16  
 Packing of Materiel for Packing ..... FM 38-701

**Forms.**

Discrepancy in Shipment Report ..... SF 361  
 Equipment Inspection and Maintenance Worksheet ..... DA Form 2404  
 Product Quality Deficiency Report ..... SF 368  
 Recommended Changes to Equipment Technical Publications ..... DA Form 2028-2  
 Report of Discrepancy ..... SF 364  
 Report of Packaging and Handling Deficiencies..... SF 362

**Technical Manuals.**

Destruction of Army Material to Prevent Enemy Use ..... TM 750-244-1-3  
 Commercial, Off-the-Shelf Manual ..... Stacked Washer/Dryer Installation Instructions  
 Commercial, Off-the-Shelf Manual ..... Maytag Laundering Tips  
 Commercial, Off-the-Shelf Manual ..... Sump Pump Installation Guide  
 Commercial, Off-the-Shelf Manual ..... Freshwater Pump Installation Guide  
 Operator's and Unit Maintenance Manual (Including RPSTL)  
 Tank, Fabric, Self Supporting, 3000 Gallon Water ..... TM 10-5430-237-12&P  
 Operator Unit and Direct Support Maint. Manual for Tent, Extendable, Modular,  
 Personnel (TEMPER) ..... TM 10-8340-224-13

---

**Technical Manuals-Continued.**

Operator, Unit, and Direct Support Maintenance Manual for Distribution  
Illumination Systems, Electrical (DISE), and Power Distribution Illumination  
Systems, Electrical (PDISE) consisting of Electrical Feeder System  
M200, M200 A/P, M100, M100 A/P, M40, M40 A/P, M60, M60 A/P  
And Electrical Utility Assembly M46 ..... TM 9-6150-226-13  
Unit and Direct Support Maintenance Manual (including Repair Parts  
And Special Tools List), General Cargo Container ..... TM 55-8115-204-23&P

**Miscellaneous Publications.**

Army Medical Department Expendable/Durable Items ..... CTA 8-100  
Expendable/Durable Items ..... CTA 50-970

---

**CONTAINERIZED SELF SERVICE LAUNDRY (CSSL)**  
**NSN 3510-01-485-0457**  
**THE ARMY MAINTENANCE SYSTEM MAC**

---

**Introduction.** This introduction provides a general explanation of all maintenance and repair functions authorized at various maintenance levels under the standard Army Maintenance System concept.

The MAC (immediately following the introduction) designates overall authority and responsibility for the performance of maintenance functions on the identified end item or component. The application of the maintenance functions to the end item or component shall be consistent with the capacities and capabilities of the designated maintenance levels, which are shown on the MAC in column (4) as:

- Unit - includes two sub columns, C (operator/crew) and O (unit) maintenance
- Direct Support - includes an F sub column, Direct Support Maintenance
- General Support - includes an H sub column, General Support Maintenance
- Depot - includes a D sub column, Depot Maintenance

The tools and test equipment requirements (immediately following the MAC) list the tools and test equipment (both special tools and common tool sets) required for each maintenance function as referenced from the MAC.

The remarks (immediately following the tools and test equipment requirements) contain supplemental instructions and explanatory notes for a particular maintenance function.

**Maintenance Functions.** Maintenance functions will be limited to and are defined as follows:

**Inspect.** To determine the serviceability of an item by comparing its physical, mechanical, and/or electrical characteristics with established standards through examination (e.g., by sight, sound, or feel).

**Test.** To verify serviceability by measuring the mechanical, pneumatic, hydraulic, or electrical characteristics of an item and comparing those characteristics with prescribed standards

**Service.** Operations required periodically to keep an item in proper operating condition, e.g. to clean (includes decontaminate, when required), to preserve, to drain, to paint, or to replenish fuel, lubricants, chemical fluids, or gases.

**Adjust.** To maintain or regulate, within prescribed limits, by bringing into proper or exact position, or by setting the operating characteristics to specified parameters.

**Align.** To adjust specified variable elements of an item to bring about optimum performance.

**Calibrate.** To determine and cause corrections to be made, or to be adjusted on instruments, tests, measuring, and diagnostic equipment used in precision measurement. Consists of comparisons of two instruments, one of which is a certified standard of known accuracy, to detect and adjust any discrepancy in the accuracy of the instrument being compared.

**Remove/Install.** To remove and install the same item when required to perform service or other maintenance functions. Install may be the act of emplacing, seating or fixing into position a spare, repair part or module (component or assembly), in a manner to allow the proper function of equipment or system.

**Replace.** To remove an unserviceable item and install a serviceable counterpart in its place. Replace is authorized by the MAC and is shown as the 3rd position code of the Source, Maintenance, and Recoverability (SMR) code.

**Repair.** The application of maintenance services, including fault location/troubleshooting, removal/installation, and disassembly/assembly procedures, and maintenance actions to identify troubles, and restore serviceability to an item by correcting specific damage, fault, malfunction, or failure in a part, subassembly, module (component or assembly), end item, or system.

### NOTE

The following definitions are applicable to the "repair" maintenance function:

Services - Inspect, test, service, adjust, align, calibrate, and/or replace.

Fault location/troubleshooting-The process of investigating and detecting the cause of equipment malfunctioning; the act of isolating a fault within a system or Unit Under Test (UUT).

Disassembly/assembly-The step by step breakdown (taking apart) of a spare/functional group coded item to the level of its least component, that is assigned an SMR code for the level of maintenance under consideration (i.e. identified as maintenance significant).

Actions-Welding, grinding, riveting, straightening, facing, machining, and/or resurfacing.

**Overhaul.** That maintenance effort (service/action) prescribed to restore an item to a completely serviceable/operational condition as required by maintenance standards in appropriate technical publications (i.e., DMWR). Overhaul is normally the highest degree of maintenance performed by the Army. Overhaul does not normally return an item to like new condition.

**Rebuild.** Consists of those services/actions necessary for the restoration of unserviceable equipment to a like new condition in accordance with original manufacturing standards. Rebuild is the highest degree of material maintenance applied to Army equipment. The rebuild operation includes the act of returning to zero those age measurements (hours/miles, etc.) considered in classifying Army equipment/components.

#### **Explanation of Columns in the MAC.**

Column 1. Group Number. Column 1 lists functional group code numbers, the purpose of which is to identify maintenance significant components, assemblies, subassemblies, and modules with the next higher assembly. End item group numbers are 00.

Column 2. Component/Assembly. Column 2 contains the names of components, assemblies, subassemblies, and modules for which maintenance is authorized.

Column 3. Maintenance Function. Column 3 lists the functions performed on the item listed in Column 2. (For a detailed explanation, refer to the previous section entitled "Maintenance Functions")

Column 4. Maintenance Level. Column 4 specifies, by the listing of a work time figure (expressed as man-hours shown as whole hours or decimals) in the appropriate subcolumn(s), the level of maintenance authorized to perform the function listed in Column (3). This figure represents the active time required to perform that maintenance function at the indicated level of maintenance. If the number or the complexity of the tasks within the listed maintenance function vary at different maintenance levels, appropriate work time figures will be shown for each level. The work time figure represents the average time required to restore an item (assembly, subassembly, component, module, end item, or system) to a serviceable condition under typical field operating conditions. This time includes item preparation (including any necessary disassembly/assembly time), troubleshooting/fault location time, and quality assurance/quality control time in addition to the time required to perform the specific tasks identified for the maintenance functions authorized in the maintenance allocation chart. The system designations for the various maintenance levels are shown below:

- C ..... Operator or crew
- O ..... Direct Support Maintenance
- F ..... Depot Maintenance
- H ..... Unit Maintenance
- D ..... General Support Maintenance

Column 5. Tools and Equipment. Column 5 specifies, by code, those common tool sets (not individual tools) common TMDE, and special tools, special TMDE, and support equipment required to perform the designated function.

Column 6. Remarks. This column, when applicable, contains a letter code, in alphabetic order, which is keyed to the remarks contained in Table 3.

**Explanation of Columns in the Tools and Test Equipment Requirements.**

Column 1. Tool or Test Equipment Reference Code. The tool or test equipment reference code correlates with a code used in column (5) of the MAC.

Column 2. Maintenance Level. The lowest level of maintenance authorized to use the tool or test equipment.

Column 3. Nomenclature. Name or identification of tool or test equipment.

Column 4. National Stock Number (NSN). The NSN of the tool or test equipment.

Column 5. Tool Number. The manufacturer's part number, model number, or type number.

**Explanation of Columns in Remarks.**

Column 1. Remarks Code. The code recorded in Column (6) of the MAC.

Column 2. Remarks. This column lists information pertinent to the maintenance function being performed as indicated in the MAC.

**Table -1. MAC for Containerized Self Service Laundry (CSSL)**

(1) Group Number	(2) Component/Assembly	(3) Maintenance Function	(4) Maintenance Level					(5) Tools & Equip.	(6) Remarks
			Operator	Unit	Direct Support	General Support	Depot		
			C	O	F	H	D		
00	Containerized Self Service Laundry (CSSL)	Inspect Test Service Repair Replace							
01	Cargo Container	Inspect		0.10					A
0101	Modified Folding Steps	Inspect Replace			0.10 0.10			1	
0102	Roofgrip	Inspect Replace		0.10 0.10					
02	Electrical System	Inspect Test Replace Repair							
0201	Power Entry Connectors	Inspect Test		0.10	0.25			3	
0202	Power Distribution Panel	Inspect Test Replace		0.10	0.10 1.50			3 1	
0203	Fluorescent lights	Inspect Test Repair Replace		0.10 0.30	0.10 0.50			1	





**Table-1. MAC for Containerized Self Service Laundry (CSSL)-Continued.**

(1) Group Number	(2) Component/Assembly	(3) Maintenance Function	(4) Maintenance Level					(5) Tools & Equip.	(6) Remarks
			Operator	Unit	Direct Support	General Support	Depot		
			C	O	F	H	D		
05	Washer/Dryer	Inspect Repair Replace		0.20	0.30 1.40				F
06	Vent Fan	Inspect Test Repair Replace		0.20	0.10 0.75 0.50		2 1 1		H
08	Space Heater	Inspect Test Service Replace		0.10	0.20 0.20 0.25		2 1 1		J
09	3,000 Gallon Tank	Inspect		0.20					K
10	Water Hoses	Inspect Repair Replace		0.30 0.50 0.50			1		
11	CSSL Modified End Section	Inspect Replace		0.10 0.50			9		L

**Table-2. Tools and Test Equipment for Containerized Self Service Laundry.**

Tool or Test Equipment Ref Code	Maintenance Level	Nomenclature	National Stock Number	Tool Number
1	O	Tool Kit, General Mech. Automotive	5180-00-177-7033	SC 5180-90-CL-N26
2	F	Tool Kit, Org. Maintenance Common No.1	4910-00-754-0654	SC 4910-95-A74
3	F	Tool Kit, Electronic Equipment	5180-01-460-9328	SC 5180-91-R64
4	F	Pipe Wrench, 18"	5120-00-277-1479	
5	F	Pipe Wrench, 10"	5120-00-277-1477	
6	F	Tube Cutter	5110-00-288-6520	
7	F	Hacksaw Frame	5110-00-289-9657	
8	F	Hacksaw Blade	5110-00-277-4588	
9	O	Tent Repair Kit	8340-00-262-5767	

**Table-3. Remarks for Containerized Self Service Laundry.**

Remarks Code	Remarks
A	For General Cargo Container Repair Procedures Refer to TM 55-8115-204-23 & P. Repair of modified folding steps are covered in work package 0030 of this TM (10-3510-224-13&P).
B	See DISE Technical Manual, TM 9-6150-226-13.
C	Prepare new fresh water pump for installation as described in Work Package 0032 00.
D	Prepare new pressure switch for installation as described in Work Package 0034 00.
E	Prepare new sump pump for installation as described in Work Package 0035 00.
F	See washer/dryer Commercial Manual.
G	Prepare new washer/dryer for installation as described in Work Package 0037 00.
H	Prepare new ventilation fan for installation as described in Work Package 0038 00.
I	See TEMPER Technical Manual, TM 10-8340-224-13.
J	Prepare new heater for installation as described in Work Package 0039 00.
K	Refer to Tank, Fabric, Self-Supporting, 3,000 Gallon Water, TM10-5430-227-12&P.
L	Refer to FM 10-16, General Fabric Repair.

**END OF WORK PACKAGE**

THIS PAGE INTENTIONALLY LEFT BLANK

**CONTAINERIZED SELF SERVICE LAUNDRY (CSSL)  
NSN 3510-01-485-0457  
REPAIR PARTS AND SPECIAL TOOLS LIST (RPSTL)**

**INTRODUCTION TO REPAIR PARTS AND SPECIAL TOOLS LIST.**

**SCOPE.** This RPSTL lists and authorizes spare and repair parts, special tools, special tests, measurement, and diagnostic equipment (TMDE); and other special support equipment required for performance of unit and direct support maintenance of the CSSL. It authorizes the requisitioning, issue, and disposition of spares, repair parts, and special tools as indicated by the Source, Maintenance, and Recoverability (SMR) codes.

**GENERAL.** In addition to this section, this RPSTL is divided into the following additional sections:

**Repair Parts Sections.** These sections contain lists of spares and repair parts authorized by this RPSTL for use in the performance of maintenance. These sections also include parts that must be removed for replacement of the authorized parts. Parts lists are composed of functional groups in ascending alphanumeric sequence, with the parts in each group listed in ascending figure and item number sequence. Hardware is listed with the components used. Bulk materials are listed by item name in FIG. BULK at the end of the sections. Repair parts kits are listed separately in their own functional group and section. Repair parts for repairable special tools are also listed in a separate section. Items listed are shown on the associated illustrations.

**Special Tools List Sections.** Sections containing lists of special tools, special TMDE, and special support equipment authorized by this RPSTL (as indicated by Basis of Issue (BOI) information in the DESCRIPTION AND USABLE ON CODE (UOC) column). Tools that are components of common tool sets and/or Class VII are not listed.

**Cross-Reference Index Sections.** There are two cross-reference indexes in this RPSTL; the National Stock Number (NSN) Index, and the Part Number Index. The NSN index refers you to the figure and the item number. The part number index also refers you to the figure and item number.

**EXPLANATION OF COLUMNS IN THE RPSTL.**

**ITEM NO. (Column (1)).** Indicates the number used to identify items called out in the illustration.

**SMR Code (Column (2)).** The Source, Maintenance, and Recoverability (SMR) code is a 5-position code containing supply / requisitioning information, maintenance category authorization criteria and disposition instruction, as shown in the following breakout.

Source Code	Maintenance Code	Recoverability Code
<b>X X</b>	<b>X</b>	<b>X</b>
1st two positions:	3rd Position:	4th Position:
5th Position:		
How you get an item	Who can install replace or use the item	Who can do complete repair* on the item
		Who determines disposition action on an item

\*Complete Repair: Maintenance capacity, capability, and authority to perform all corrective maintenance tasks of the

Repair function in a use/user environment in order to restore serviceability to a failed item.

**Source Code.** The source code tells you how to get an item for maintenance, repair or overhaul of an end item/equipment. Explanation of source codes follows.

<b>Source Code</b>	<b>Explanation</b>
PA	Stock items: use the applicable NSN to request/requisition items with these source codes. They are authorized to the category indicated by the code entered in the third position of the SMR code.
PB	
PC**	
PD	
PE	
PF**	
PG	NOTE: Items coded PC are subject to deterioration.
KB	Items with these codes are not to be requested/requisitioned individually. They are part of a kit which is authorized to the maintenance category indicated in the 3rd position of the SMR code. The complete kit must be requisitioned and applied.
KD	
KF	
MO - Made at unit/AVUM Level	Items with these codes are not to be requested/requisitioned individually. They must be made from bulk material that is identified by the part number in the DESCRIPTION AND USABLE ON CODE (UOC) column and listed in the Bulk Material group of the repair parts list in this RPSTL. If the item is authorized to you by the 3rd position code of the SMR code, but the source code indicates it is made at a higher level, order the item from the higher level of maintenance.
MF- Made at DS/AVIM Level	
MH - Made at GS Level)	
ML - Made at Specialized RepairAct. (SRA)	
MD - Made at Depot	
AO - Assembled by Unit/AVUM Level	Items with these codes are not to be requested/requisitioned individually. The parts that make up the assembled item must be requisitioned or fabricated and assembled at the level of maintenance indicated by the source code. If the third position code of the SMR code authorizes you to replace the item, but the source code indicates the item is assembled at a higher level, order the item from the higher level of maintenance.
AF - Assembled by DS/AVIM Level	
AH - Assembled by GS level	
AL - Assembled by SRA order the item from the higher level of maintenance.	
AD - Assembled by Depot	
XA	Do not requisition an "XA" coded item. Order its next higher assembly. (Also, refer to the NOTE below.)
XB	If an "XB" item is not available from salvage, order it using the CAGEC and part number given.
XC	Installation drawing, diagram, instruction sheet, field service drawing, that is identified by manufacturer's part number.
XD	Item is not stocked. Order an "XD" coded item through normal supply channels using the Commercial and Government Entity Code (CAGEC) and part number given, if no NSN is available.

---

**NOTE**

---

Cannibalization or controlled exchange, when authorized, may be used as a source of supply for items with the above source codes, except for those source coded "XA" or those aircraft support items restricted by requirements of AR 750-1.

**Maintenance Code.** Maintenance codes tell you the level(s) of maintenance authorized to use and repair support items. The maintenance codes are entered in the third and fourth positions of the SMR Code as follows:

**Third Position.** The maintenance code entered in the third position tells you the lowest maintenance level authorized to remove, replace, and use the support item. The maintenance code entered in the third position will indicate authorization to one of the following levels of maintenance.

<b>Maintenance Code</b>	<b>Application/Explanation</b>
C	Crew or operator maintenance done within unit/AVUM maintenance.
O	Unit level/AVUM maintenance can remove, replace, and use the item.
F	Direct support/AVIM maintenance can remove, replace, and use the item.
H	General support maintenance can remove, replace, and use the item.
L	Specialized repair activity can remove, replace, and use the item.
D	Depot level can remove, replace, and use the item.

**Fourth Position.** The maintenance code entered in the fourth position tells whether or not the item is to be repaired and identifies the lowest maintenance level with the capability to do complete repair (i.e., perform all authorized repair functions).

---

**NOTE**

---

Some limited repair may be done on the item at a lower level of maintenance, if authorized by the Maintenance Allocation Chart (MAC) and SMR codes.

<b>Maintenance Code</b>	<b>Application/Explanation</b>
O	Unit/AVUM is the lowest level that can do complete repair of the item.
F	Direct support/AVIM is the lowest level that can do complete repair of the item.
H	General support is the lowest level that can do complete repair of the item.
L	Specialized repair activity (designate the specialized repair activity) is the lowest level that can do complete repair of the item.
D	Depot is the lowest level that can do complete repair of the item.
Z	Nonrepairable. No repair is authorized.
B	No repair is authorized. (No parts or special tools are authorized for the maintenance of a "B" coded item.) However, the item may be reconditioned by adjusting, lubricating, etc., at the user level.

**Recoverability Code.** Recoverability codes are assigned to items to indicate the disposition action on unserviceable

items. The recoverability code is entered in the fifth position of the SMR Code as follows:

Code	Application/Explanation
Z	Nonrepairable item. When unserviceable, condemn and dispose of the item at the level of maintenance shown in 3rd position of SMR Code.
O	Repairable item. When uneconomically repairable, condemn and dispose of the item at organizational or aviation unit level.
F	Repairable item. When uneconomically repairable, condemn and dispose of the item at the direct support or aviation intermediate level.
H	Repairable item. When uneconomically repairable, condemn and dispose of the item at the general support level.
D	Repairable item. When beyond lower level repair capability, return to depot. Condemnation and disposal of item not authorized below depot level.
L	Repairable item. Condemnation and disposal not authorized below Specialized Repair Activity (SRA).
A	Item requires special handling or condemnation procedures because of specific reasons (e.g., precious metal content, high dollar value, critical material, or hazardous material). Refer to appropriate manuals/ directives for specific instructions.

**NATIONAL STOCK NUMBER (NSN) (Column (3)).** The NSN for the item is listed in this column.

**CAGEC (Column (4)).** The Commercial and Government Entity Code (CAGEC) is a 5-digit numeric code that is used to identify the manufacturer, distributor, or Government agency/activity that supplies the item.

**PART NUMBER (Column (5)).** Indicates the primary number used by the manufacture, (individual company, firm, corporation, or Government activity), which controls the design and characteristics of the item by means of its engineering drawings, specifications, standards, and inspection requirements to identify an item or range of items.

### NOTE

When an item with an assigned NSN is requisitioned, the part number for the item received may be different than the part number of the item being replaced.

**DESCRIPTION AND USABLE ON CODE (UOC) (Column (6)).** This column includes the following information:

The federal item name and, when required, a minimum description to identify the item.

Part numbers of bulk materials are referenced in this column in the line entry to be manufactured/fabricated.

Hardness Critical Item (HCI). A support item that provides the equipment with special protection from electromagnetic pulse (EMP) damage during a nuclear attack.

The statement "END of FIGURE" appears just below the last item description in Column (5) for a given figure in both the repair parts list and special tools list.



**QTY (Column 8).** The QTY (quantity per figure) is prepared for a functional group, subfunctional group, or an assembly. A "V" appearing in this column instead of quantity indicates that the quantity is a variable with each application.

### EXPLANATION OF CROSS REFERENCE INDEX FORMAT AND COLUMNS.

#### National Stock Number (NSN) Index.

**Stock Number Column.** This column lists the NSN in national item identification number (NIIN) sequence. The NIIN consists of the last nine digits of the NSN, i.e.

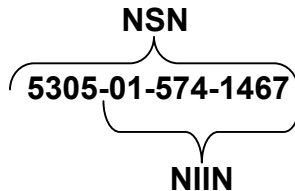

When using this column to locate an item, ignore the first four digits of the NSN. Use the complete NSN (13 digits) when requisitioning by stock number.

**Fig. Column.** This column lists the number of the figure where the item is identified/located. The figures are in numerical order in Section II and Section III.

**Item Column.** The Item number identifies the item associated with the figure listed in the adjacent FIG. Column. This item is also identified by the NSN listed on the same line.

**Part Number Index.** Part numbers in this index are listed by part number in ascending alphanumeric sequence (i.e. vertical arrangement of letter and number combination which place the first letter or digit of each group in order A through Z, followed by the numbers 0 through 9, and each following letter or digit in like order).

**CAGEC Column.** The Commercial and Government Entity Code (CAGEC) is a 5-digit numeric code used to identify the manufacturer, distributor, or Government agency/activity that supplies the item.

**Part Number Column.** Indicates the primary number used by the manufacturer (individual, firm, corporation, or government activity), which controls the design and characteristics of the item by means of its engineering drawings, specifications, standards and inspection requirements to identify an item or range of items.

**Stock Number Column.** This column lists the NSN for the associated part number and manufacturer identified in the PART NUMBER and CAGEC columns to the left.

**Fig. Column.** This column lists the number of the figure where the item is identified/located in the repair parts list and special tools list.

**Item Column.** The item number is that number assigned to the item as it appears in the figure referenced in adjacent figure number column.

**Reference Designator Column.** Indicates the reference designator assigned to the item.

**Fig Column.** This column lists the number of the figure where the item is identified/located in the repair parts list and special tools list.

**Item Column.** The item number is that number assigned to the item as it appears in the figure referenced in the adjacent figure number column.

**Stock Number Column.** This column lists the NSN for the item.

**CAGE Column.** The Commercial and Government Entity Code (CAGEC) is a 5-digit numeric code used to identify the manufacturer, distributor, or Government agency/activity that supplies the item.

**Part Number Column.** Indicates the primary number used by the manufacturer (individual, firm, corporation, or Government activity), which controls the design and characteristics of the item by means of its engineering drawings, specifications, standards, and inspection requirements to identify an item or range of items.

#### **SPECIAL INFORMATION.**

**Usable On Code (UOC).** The useable on code appears in the lower left corner of the Description Column heading. Useable on codes are shown as UOC in the Description Column (justified left) on the first line under the applicable item description/nomenclature. Uncoded items are applicable to all models. Identification of the usable on codes used in this RPSTL are:

---

#### **NOTE**

---

There are no Usable On Codes applicable to the Containerized Self Service Laundry.

**Fabrication Instructions.** Bulk materials required to manufacture items are listed in the Bulk Material Functional Group of this RPSTL. Part numbers for bulk materials are also referenced in the description column of the line entry for the item to be manufactured/fabricated. Detailed fabrication instructions for items source coded to be manufactured or fabricated are found in TB 10-4500-200-13.

**Index Number.** Items that have the word BULK in the figure column will have an index number shown in the item number column. This index number is a cross-reference between the National Stock Number/Part Number Index and the bulk material list in Section II.

**Associated Publications.** The publications listed in work package 0002 00 under REFERENCES pertain to components and associated equipment of the Containerized Self Service Laundry.

### How To Locate Repair Parts.

**When National Stock Numbers or Part Numbers are NOT known.** First, using the table of contents, determine the assembly or subassembly group to which the item belongs. This is necessary since figures are prepared for assembly groups and subassembly groups, and listings are divided into the same groups.

Second, find the figure covering the assembly group or subassembly group to which the item belongs.

Third, identify the item on the figure and note the number(s).

Fourth, look in the repair parts list for the figure and item numbers. The NSNs and part numbers are on the same line as the associated item numbers.

**When National Stock Numbers or Part Numbers ARE NOT known.** First, if you have the NSN, look in the STOCK NUMBER column of the NSN index. The NSN is arranged in NIIN sequence. Note the figure and item number next to the NSN.

Second, turn to the figure and locate the item number. Verify that the item is the one you are looking for.

**When Part Number is known.** First, if you have the P/N and not the NSN, look in the PART NUMBER column of the P/N index. Identify the figure and item number.

Second, look up the item on the figure in the applicable repair parts list.

THIS PAGE INTENTIONALLY LEFT BLANK

THIS PAGE INTENTIONALLY LEFT BLANK

---

**GROUP 01 CARGO CONTAINER  
REPAIR PARTS AND SPECIAL TOOLS LIST**

---

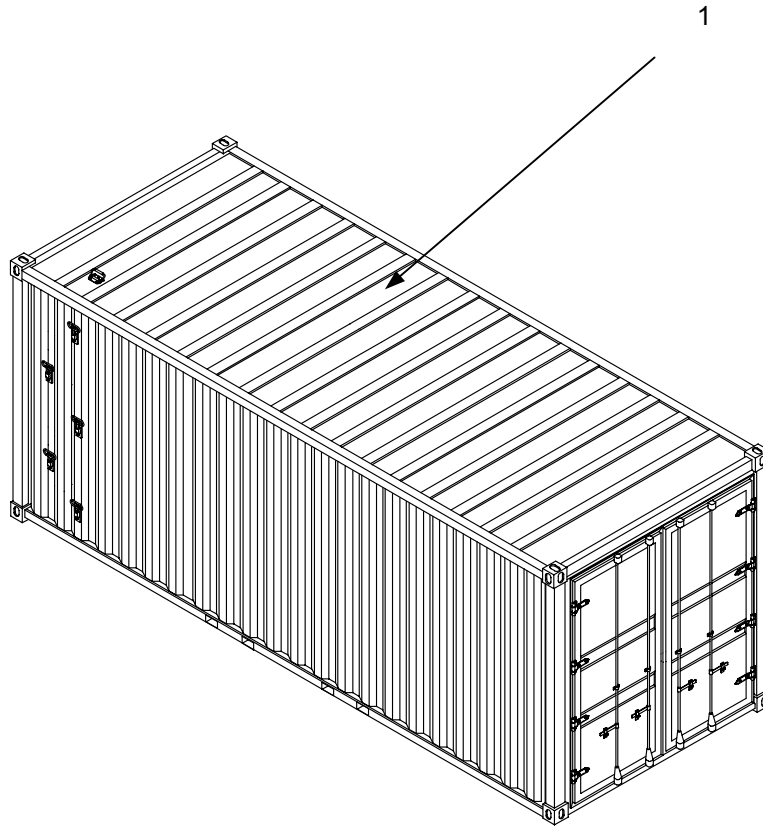

**Figure 1. Group 01 Cargo Container.**

(1) ITEM NO.	(2) SMR CODE	(3) NSN	(4) CAGEC	(5) PART NUMBER	(6) DESCRIPTION AND USABLE ON CODE (UOC)	(7) QTY
					GROUP 01 CARGO CONTAINER	
					FIG. 1 CARGO CONTAINER	
1	PAFZZ	8115-01-341-7524	81348	MIL-C-52661	CONTAINER, ISO 20FT	1
				END OF FIGURE		

END OF WORK PACKAGE

THIS PAGE INTENTIONALLY LEFT BLANK



THIS PAGE INTENTIONALLY LEFT BLANK

---

**GROUP 0101 MODIFIED FOLDING STEP  
REPAIR PARTS AND SPECIAL TOOLS LIST**

---

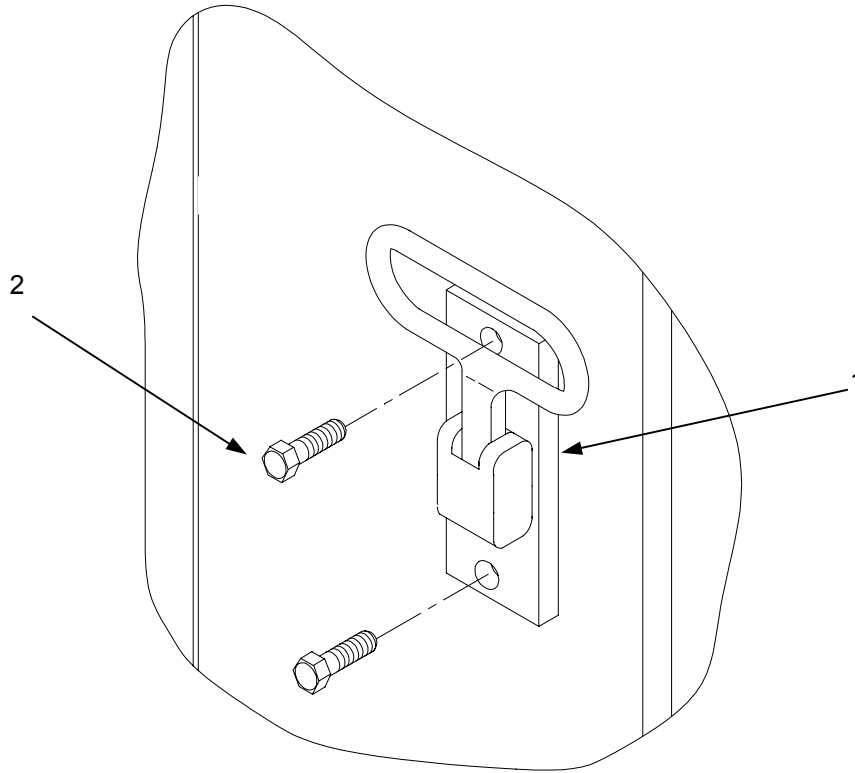

**Figure 2. Group 0101 Modified Folding Step.**

(1) ITEM NO.	(2) SMR CODE	(3) NSN	(4) CAGEC	(5) PART NUMBER	(6) DESCRIPTION AND USABLE ON CODE (UOC)	(7) QTY
					GROUP 01 CARGO CONTAINER	
					GROUP 0101 MODIFIED FOLDING STEP	
1	PAFZZ		81337	5-13-6630	FIG. 2 MODIFIED FOLDING STEP STEP, FOLDING MODIFIED	5
2	PAOZZ		96906	MS35307-334	SCREW, HEX HD (5/16-18 X 1")	10
				END OF FIGURE		

END OF WORK PACKAGE

THIS PAGE INTENTIONALLY LEFT BLANK

THIS PAGE INTENTIONALLY LEFT BLANK

**GROUP 0201 POWER ENTRY CONNECTORS  
REPAIR PARTS AND SPECIAL TOOLS LIST**

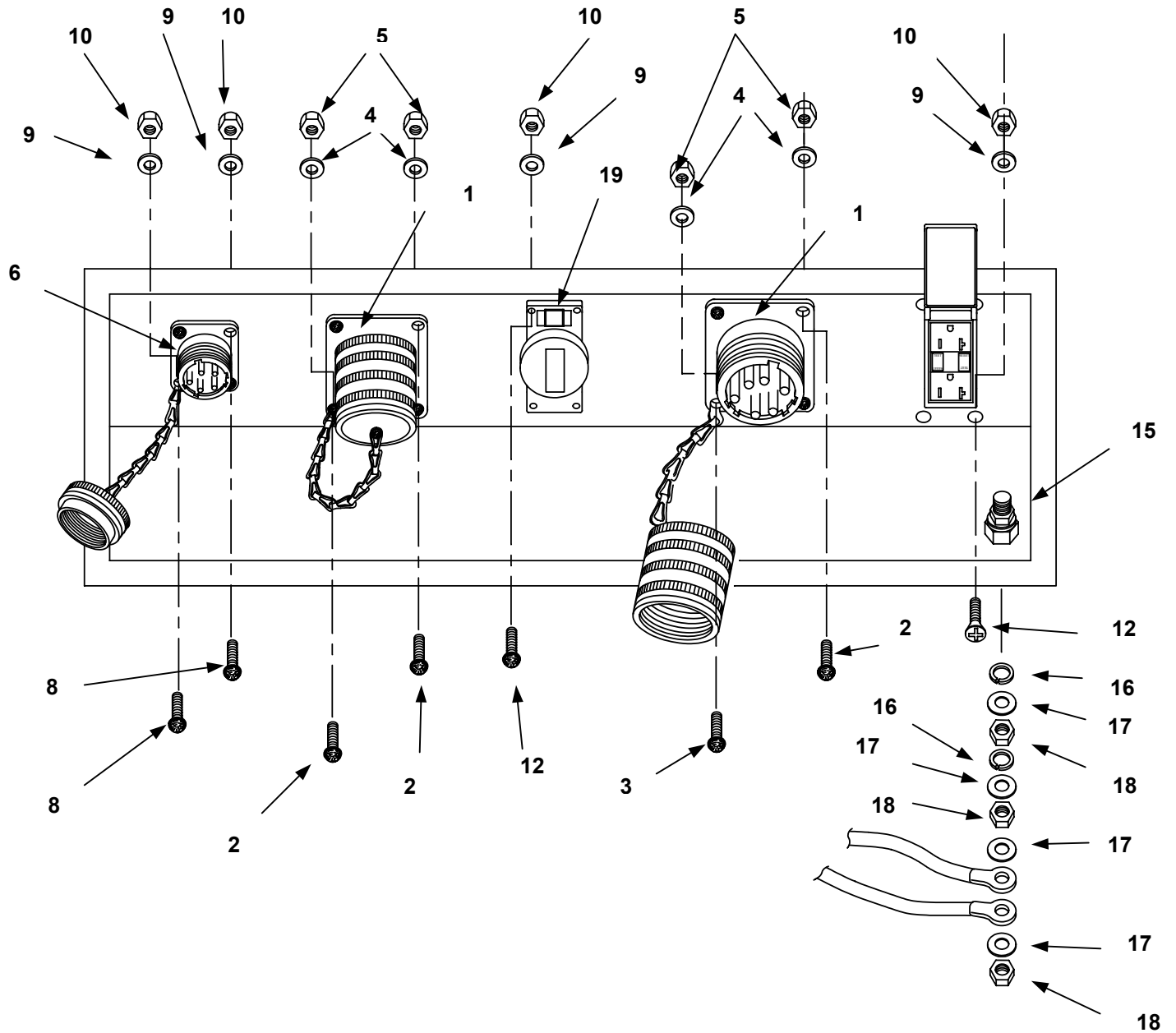

Figure 3. Group 0201 Power Entry Connectors.

(1) ITEM NO.	(2) SMR CODE	(3) NSN	(4) CAGEC	(5) PART NUMBER	(6) DESCRIPTION AND USABLE ON CODE (UOC)	(7) QTY
GROUP 02 ELECTRICAL SYSTEM						
GROUP 0201 POWER ENTRY CONNECTORS						
FIG. 3 POWER ENTRY CONNECTORS						
1			96906	MS90558C44421P	PLUG, WALL MOUNT W/PROTECTIVE COVER	2
2	PAOZZ	5305-00-059-3677	96906	MS51958-81	SCREW, PAN HEAD, .250-28UNF X .75 LONG	6
3	PAOZZ	5305-00-059-5432	96906	MS51958-82	SCREW, PAN HEAD, .250-28UNF X .87 LONG	2
4			96906	MS15795-858	WASHER, FLAT METAL, ROUND, .266 ID X .458 OD X .036 THK	8
5	PAOZZ	5310-00-889-2589	96906	MS21044C4	NUT, SELF LOCKING, HEX .250- 28UNF	8
6			96906	MS90555C324135	RECEPTACLE, WALL MOUNT W/PROTECTIVE COVER	1
7	PAOZZ	5305-00-059-3677	96906	MS51958-81	SCREW, PAN HEAD, 10-32UNF X .75 LONG	3
8	PAOZZ	5305-00-059-5432	96906	MS51958-82	SCREW, PAN HEAD, 10-32UNF X .87 LONG	1
9	PAOZZ	5310-00-615-1556	96906	MS15795-846	WASHER, FLAT, METAL ROUND .203 ID X .375 OD X .020 THICK	8
10	PAOZZ	5310-00-208-2955	96906	MS21044C3	NUT, SELF LOCKING, HEX NO. 10- 32UNF	8
11	PAOZZ	5975-01-455-7858	2F367	WPFS26	PLATE, WALL, ELECTRICAL, SINGLE GANG	1
12	PAOZZ	5305-00-071-1324	96906	MS51960-67	SCREW, MACHINE, FLAT CSK HEAD, 10-32UNF	4
13	PAOZZ	5310-99-952-1023	75582	6899	INTERRUPTER, GROUND FAULT, (GFCI)	1
14	PAOZZ	5310-00-878-3291	96906	MS21043-06	NUT, SELF LOCKING, HEX NO. 6- 32UNC	2
15	PAOZZ	5940-01-433-6259	96906	MS39347-4	TERMINAL POST, SERVICE AND GROUNDING	1
16	PAOZZ	5310-00-933-8778	96906	MS35338-143	WASHER, LOCK 1/2"	2
17			96906	MS51969	WASHER, FLAT, .531 ID X 1.062 OD X .095 THICK	4
18	PAOZZ	5310-00-913-5474	96906	MS51969-5	NUT, PLAIN, HEX 1/2-13 UNC	3
19			9C264	HBL2516	CONNECTOR, HUBBEL, TWIST LOCK 20 AMP, 120/208V, 3 PHASE, W/PROTECTIVE COVER	1
END OF FIGURE						

END OF WORK PACKAGE

THIS PAGE INTENTIONALLY LEFT BLANK



THIS PAGE INTENTIONALLY LEFT BLANK

**GROUP 0202 POWER DISTRIBUTION PANEL  
REPAIR PARTS AND SPECIAL TOOLS LIST**

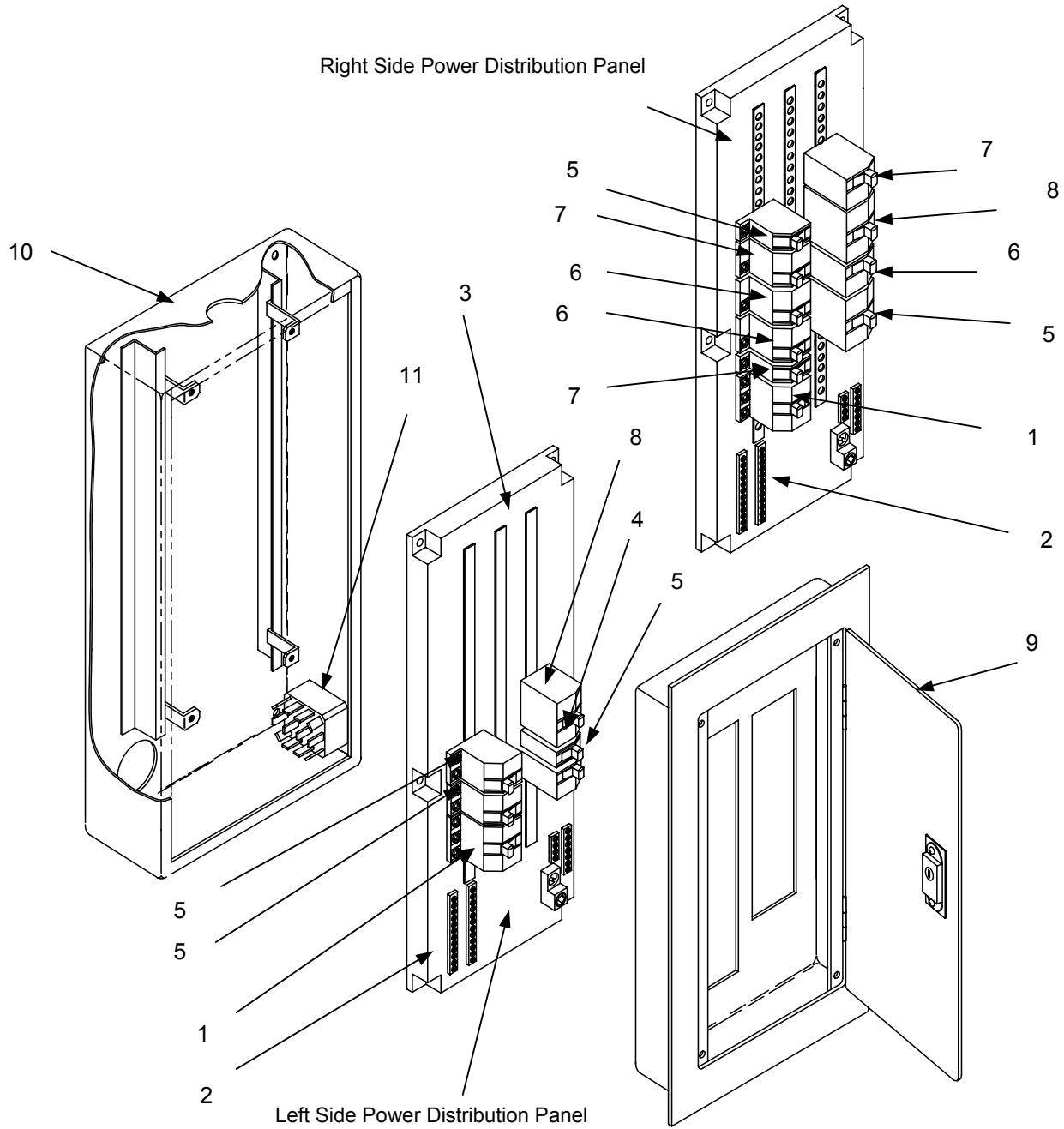

**Figure 4. Group 0202 Power Distribution Panel.**

(1) ITEM NO.	(2) SMR CODE	(3) NSN	(4) CAGEC	(5) PART NUMBER	(6) DESCRIPTION AND USABLE ON CODE (UOC)	(7) QTY
					GROUP 02 ELECTRICAL SYSTEM	
					GROUP 0202 POWER DISTRIBUTION PANEL	
					FIG. 4 POWER DISTRIBUTION PANEL	
1			88753	NQOD430M100CU	PANELBOARD-100 AMP MAIN BREAKER	2
2			88753	PK18GTA-L	KIT, GROUND BAR	2
3	PAOZZ	5342-01-296-6407	88753	QOFP	FILLER PLATE	1
4	PAOZZ	5925-00-984-2163	56303	QOB115	CIRCUIT BREAKER 15 AMP, 2 POLE	2
5	PAOZZ	5925-00-936-3933	56303	QOB360	CIRCUIT BREAKER 60 AMP, 3 POLE	2
6	PAOZZ	5925-00-062-3743	56303	QOB230	CIRCUIT BREAKER 30 AMP, 2 POLE	6
7	PAOZZ	5925-00-983-5666	56303	QOB315	CIRCUIT BREAKER 15 AMP, 3 POLE	2
8			56303	QOB310	CIRCUIT BREAKER 10 AMP, 3 POLE	2
9			81337	5-13-6627-2	ELECTRICAL BOX COVER	2
10			81337	5-13-6624-2	ELECTRICAL BOX ASSEMBLY	2
END OF FIGURE						

END OF WORK PACKAGE

THIS PAGE INTENTIONALLY LEFT BLANK

THIS PAGE INTENTIONALLY LEFT BLANK

TM 10-3510-224-13&P  
GROUP 0203 FLUORESCENT LIGHTS  
REPAIR PARTS AND SPECIAL TOOL LIST

0048 00

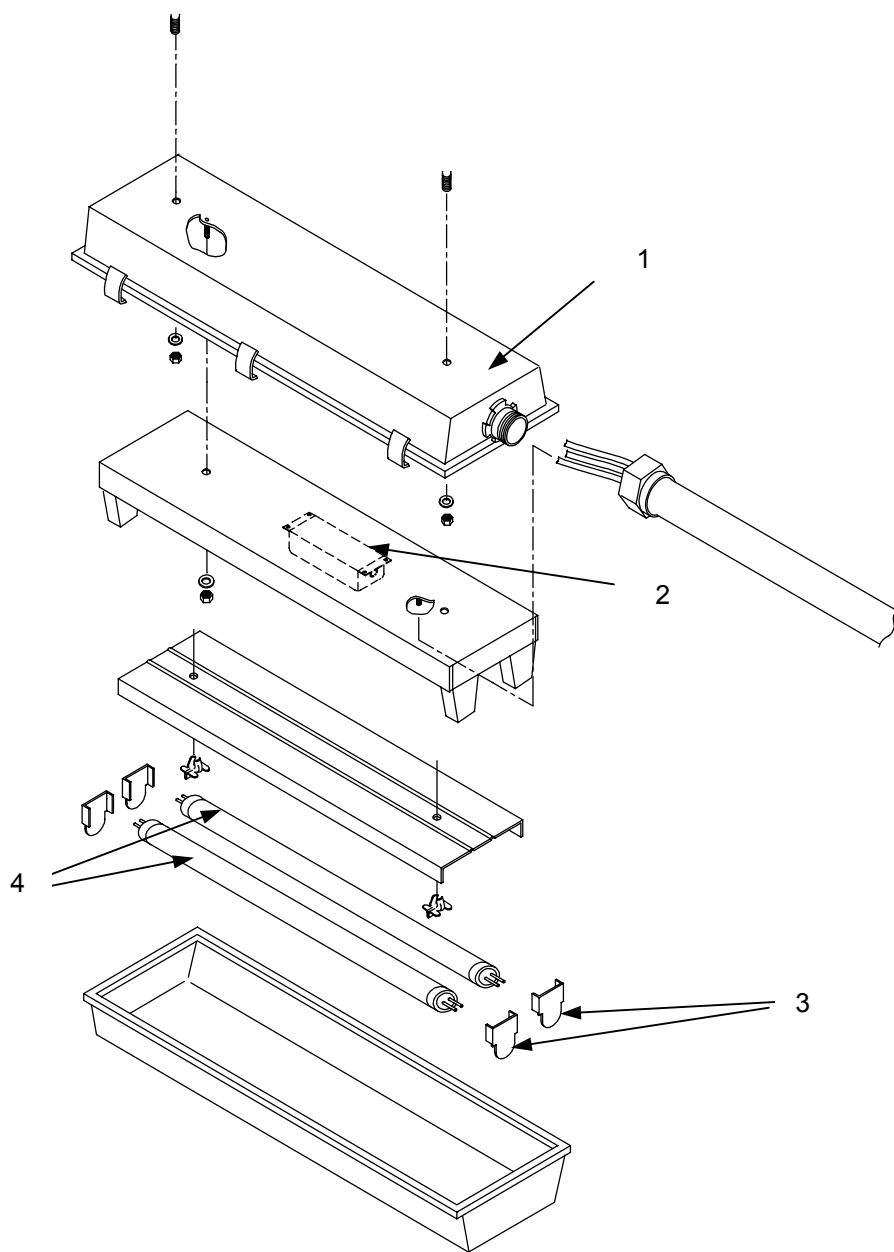

Figure 5. Group 0203 Fluorescent Lights.

(1) ITEM NO.	(2) SMR CODE	(3) NSN	(4) CAGEC	(5) PART NUMBER	(6) DESCRIPTION AND USABLE ON CODE (UOC)	(7) QTY
					GROUP 02 ELECTRICAL SYSTEM	
					GROUP 0203 FLUORESCENT LIGHTS	
					FIG. 5 FLUORESCENT LIGHTS	
1			2F367	6F555	FIXTURE, FLUORESCENT, MOISTURE/DUST RESISTANT	3
2		6250-01-377-6572			BALLAST	3
3			57094	MT91505	RETAINER, ELECTRICAL	12
4	PAOZZ	6240-01-457-7978	2F367	3V477	LIGHT, FLUORESCENT, GENERAL PURPOSE, 48"	6
END OF FIGURE						

END OF WORK PACKAGE

THIS PAGE INTENTIONALLY LEFT BLANK



THIS PAGE INTENTIONALLY LEFT BLANK

**GROUP 0204 INTERIOR SWITCHES AND RECEPTACLES  
REPAIR PARTS AND SPECIAL TOOLS LIST**

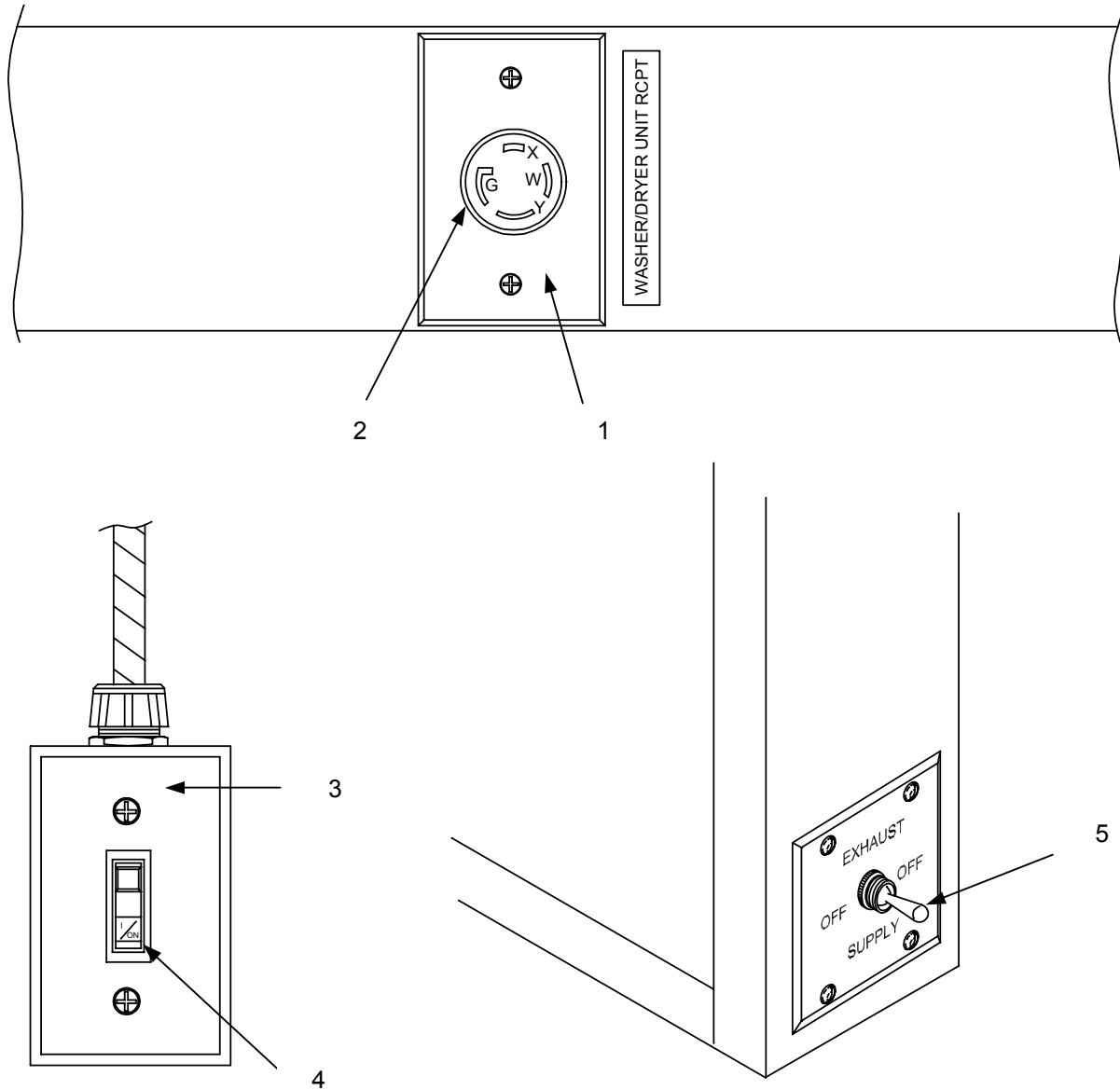

Figure 6. Group 0204 Interior Switches and Receptacles.

(1) ITEM NO.	(2) SMR CODE	(3) NSN	(4) CAGEC	(5) PART NUMBER	(6) DESCRIPTION AND USABLE ON CODE (UOC)	(7) QTY
					GROUP 02 ELECTRICAL SYSTEM	
					GROUP 0204 INTERIOR SWITCHES AND RECEPTACLES	
					FIG. 6 INTERIOR SWITCHES AND RECEPTACLES	
1			9C624	A720	WALL PLATE RECEPTACLE, ALUMINUM ANODIZED	6
2			9C624	2710A	CONNECTOR, RECEPTACLE TWIST LOCK 30 AMP	6
3			9C624	CS1 15W	AC SWITCH, 15 AMP, SINGLE POLE	1
4			9C624	A1	SWITCH PLATE, 1 GANG, METAL, ALUMINUM	1
5			25795	05226001	SWITCH (SWITCH COVER INCLUDED)	1
				END OF FIGURE		

END OF WORK PACKAGE

THIS PAGE INTENTIONALLY LEFT BLANK

THIS PAGE INTENTIONALLY LEFT BLANK

TM 10-3510-224-13&P  
GROUP 0205 EXTERIOR POWER CABLES  
REPAIR PARTS AND SPECIAL TOOLS LIST

0050 00

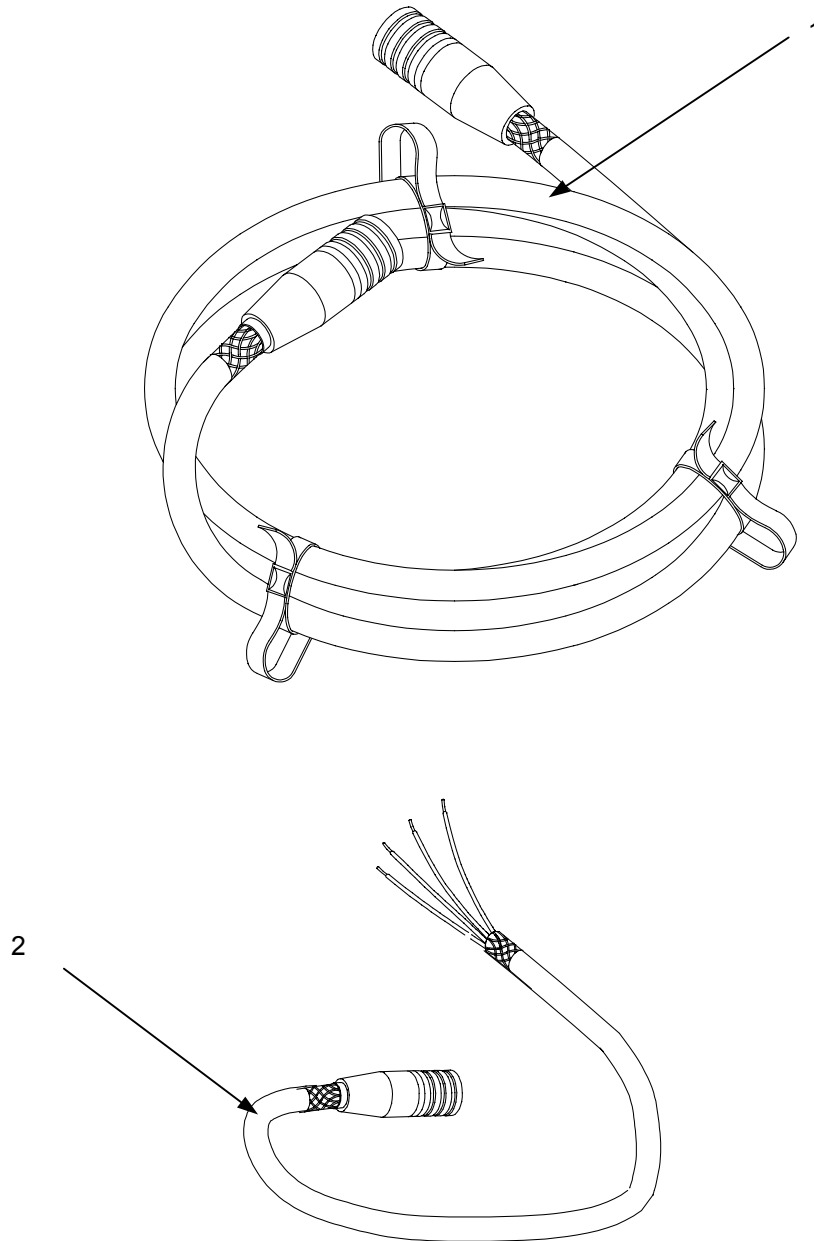

Figure 7. Group 0205 Exterior Power Cables.

(1) ITEM NO.	(2) SMR CODE	(3) NSN	(4) CAGEC	(5) PART NUMBER	(6) DESCRIPTION AND USABLE ON CODE (UOC)	(7) QTY
					GROUP 02 ELECTRICAL SYSTEM	
					GROUP 0205 EXTERIOR POWER CABLES	
					FIG. 7 EXTERIOR POWER CABLES	
1	PAFZZ		80063	SC-D-883964 GP9-3	CABLE ASSEMBLY, ELECTRICAL, 100 AMP	2
2	PAFZZ		97403	13227E7020	CABLE, PIGTAIL, 100 AMP, 4 FT.	2
				END OF FIGURE		

END OF WORK PACKAGE

THIS PAGE INTENTIONALLY LEFT BLANK



**GROUP 0301 FRESHWATER PUMP AND INTERNAL FRESHWATER LINE  
REPAIR PARTS AND SPECIAL TOOLS LIST**

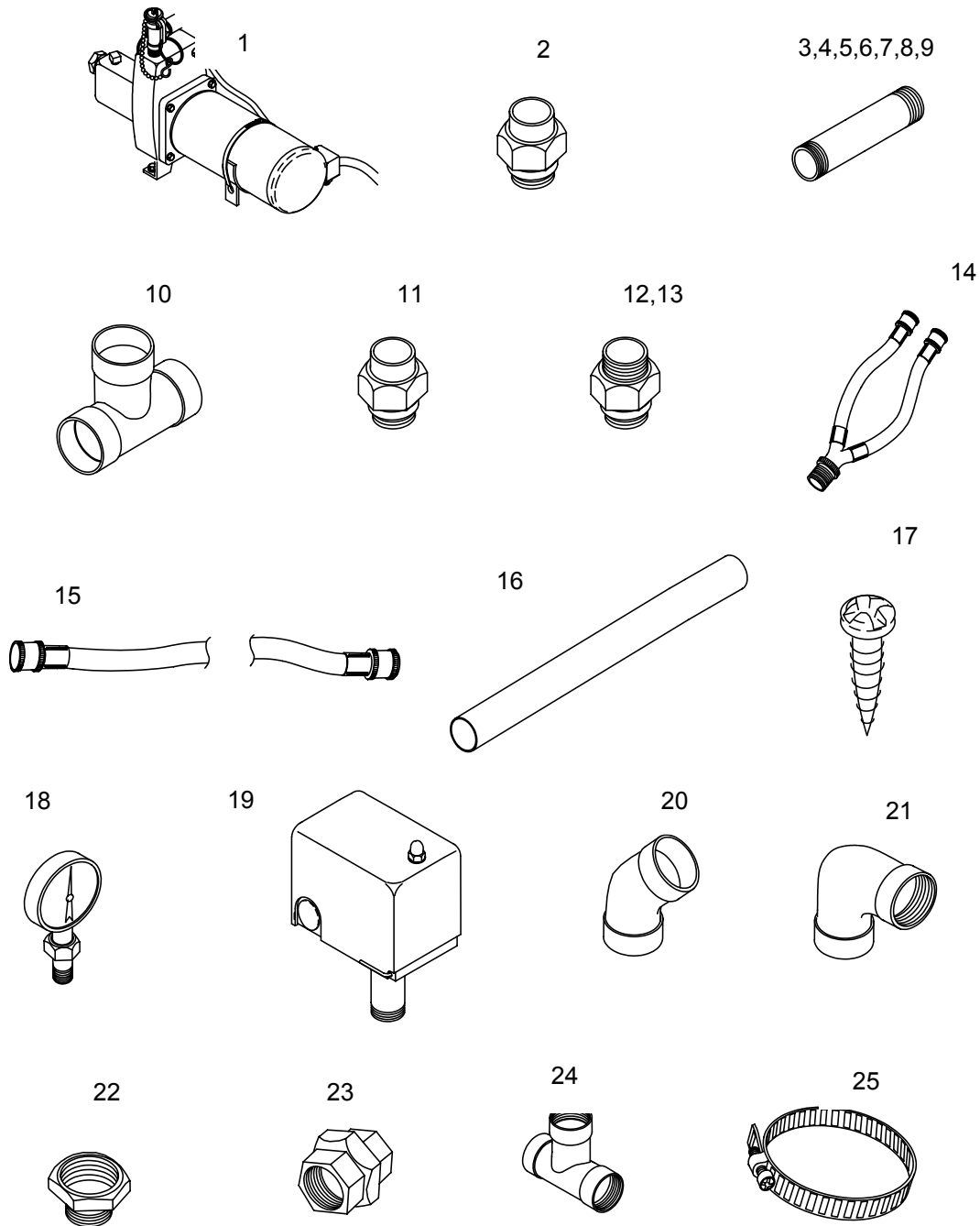

**Figure 8. Group 0301 Freshwater Pump and Internal Freshwater Line.**

(Sheet 1 of 2)

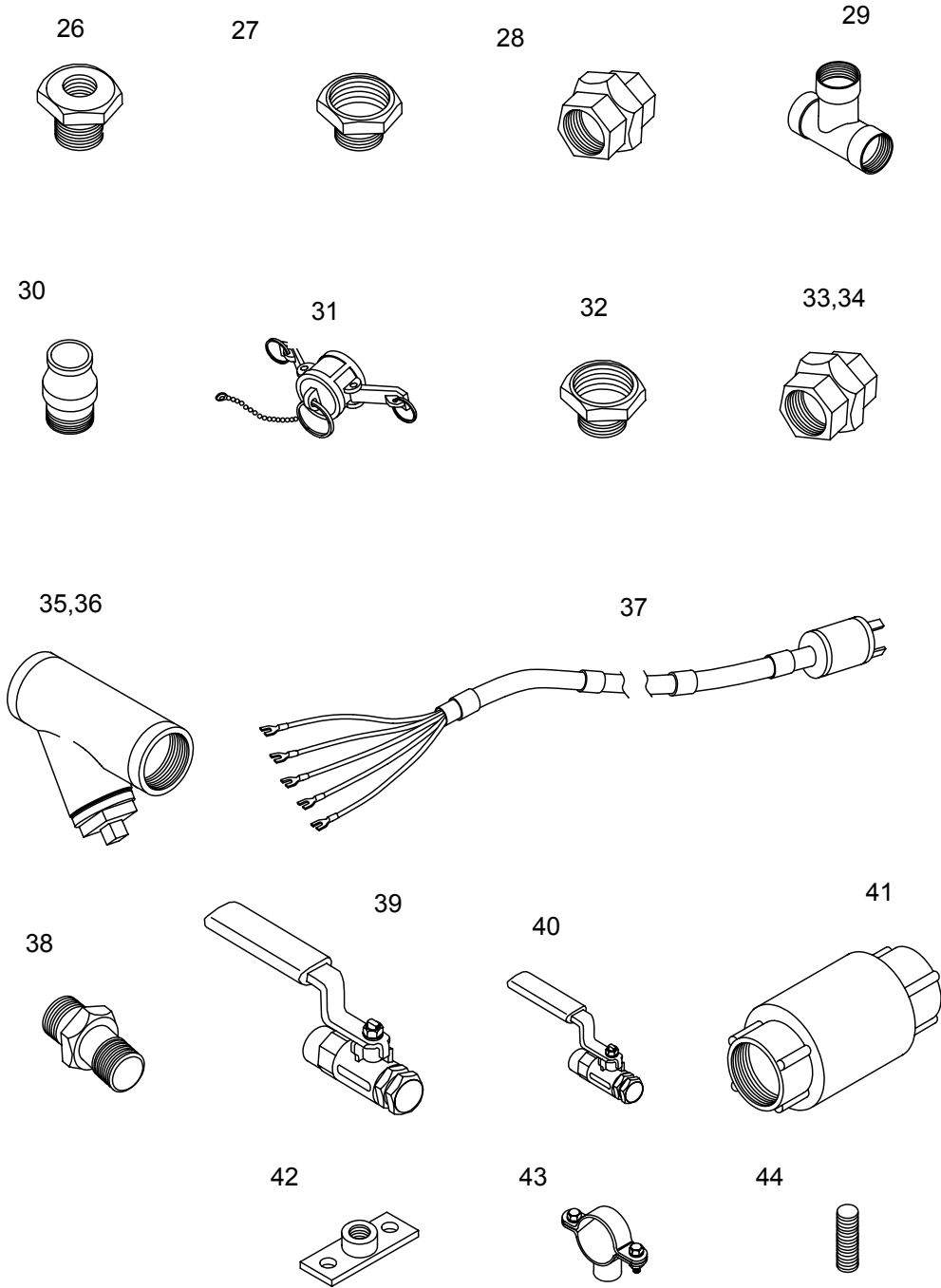

Figure 8. Group 0301 Freshwater Pump and Internal Freshwater Line.

(Sheet 2 of 2)

(1) ITEM NO.	(2) SMR CODE	(3) NSN	(4) CAGEC	(5) PART NUMBER	(6) DESCRIPTION AND USABLE ONCODE (UOC)	(7) QTY
					GROUP 03 FRESHWATER SYSTEM	
					GROUP 0301 FRESHWATER PUMP AND INTERNAL FRESHWATER LINE	
					FIG. 8 INTERNAL FRESHWATER LINE	
1	PAFZZ		25795	4RJ54	Supply Pump	1
2	PAFZZ		39428	4429k427	2 x 1 1/2" Bushing, Brass	1
3	PAFZZ		39428	4568K271	1 1/2 x 6" Long Nipple, Brass	1
4	PAFZZ		39428	4568K268	1 1/2 x 5" long Nipple, Brass	1
5	PAFZZ		39428	4568K131	1" Close Nipple, Brass	1
6	PAFZZ		39428	4568K142	1/4" x 6" long Nipple, Brass	1
7	PAFZZ		39428	4568K196	3/4" x 4" long Nipple, Brass	1
8	PAFZZ		39428	4568K192	3/4" x 2" long Nipple, Brass	1
9	PAFZZ		39428	4568K211	3/4" x 6" long Nipple, Brass	1
10	PAFZZ		39428	5520K72	3/4" Tee, Copper	6
11	PAFZZ		39428	5520K12	3/4" x 3/4" Male Adapter, Copper	1
12	PAFZZ		39428	73605T59	Male Garden Hose x 1/4" Female NPT Fitting, Brass	1
13	PAFZZ		39428	5520K509	3/4" x 1/2" NPT Male Pipe Reducing Adapter, Copper	7
14	PAFZZ		81337		Mixing Hose	6
15	PAFZZ		39089	200678	Supply Hose	6
16	PAFZZ		39428	50475K25	3/4" Copper Tubing	30 ft
17	PAFZZ		39428	90294A315	Wood Screw, No. 14 x 1" long	14
18	PAFZZ		39428	4023K14	0-1—PSI/KPA Pressure Gauge	1
19	PAFZZ		56365	9013FSG 2M4	Pressure Switch	1
20	PAFZZ		39428	5520K52	3/4" x 45 Degree Elbow, Copper	1
21	PAFZZ		39428	4429K164	3/4" x 90 Degree elbow, Brass	2
22	PAFZZ		39428	73605T57	Garden Hose to Pipe 3/4" Male Garden x 1/2" NPT	7
23	PAFZZ		39428	4429K216	1" Union, Brass	1
24	PAFZZ		39428	4429K254	3/4" x 3/4" x 3/4" Female NPT Tee, Brass	1

(1) ITEM NO.	(2) SMR CODE	(3) NSN	(4) CAGEC	(5) PART NUMBER	(6) DESCRIPTION AND USABLE ON CODE (UOC)	(7) QTY
					GROUP 03 FRESHWATER SYSTEM	
					GROUP 0301 FRESHWATER PUMP AND INTERNAL FRESHWATER LINE	
					FIG. 8 INTERNAL FRESHWATER LINE	
25	PAFZZ		25795	1A532	Hose Clamp, 5", Worm Drive, Hex Head	1
26	PAFZZ		39428	4429K461	1" NPT Male x 1/4" NPT Female Bushing, Brass	1
27	PAFZZ		39428	4568K191	3/4" Close Nipple, Brass	1
28	PAFZZ		39428	4429K218	1 1/2" Union, Brass	1
29	PAFZZ		39428	4429K255	1" x1" x1" Female NPT Tee, Brass	1
30	PAFZZ		81337	MS27026	Coupling, Half, Female x External Pipe Thread, Brass	1
31	PAFZZ		81337	MS27029	Coupling Half, Plug, Dust Brass	1
32	PAFZZ		39428	4568K222	1" x 2" long Nipple, Brass	1
33	PAFZZ		39428	4568K261	1 1/2" Close Nipple, Brass	1
34	PAFZZ		39428	4429K215	3/4" Union, Brass	1
35	PAFZZ		39428	43935K27	1 1/2" Strainer, Water, Brass	1
36	PAFZZ		39428	4385K34	Bronze Y Strainer, 3/4"NPT	1
37	PAFZZ		81337	5-13-6649	Power Cord, Pressure Switch	1
38	PAFZZ		39428	4568K191	3/4" Close Nipple, Brass	1
39	PAFZZ		39428	47865K23	1/2" Valve, Ball, NPT Brass	7
40	PAFZZ		39428	47865K21	1/2" Valve, Ball, NPT Brass	1
41	PAFZZ		39428	4616K95	1 1/2" Spring Check Valve, Brass	1
42	PAFZZ		39428	11445T1	Hanger Plate	7
43	PAFZZ		39428	3023T24	Hanger, Split-Ring Pipe Hanger	7
44	PAFZZ		39428	98837A013	Rod, Threaded, 3/8"-16 x 1.25 long	7
END OF FIGURE						

END OF WORK PACKAGE

THIS PAGE INTENTIONALLY LEFT BLANK

---

**GROUP 0302 PRESSURE TANK  
REPAIR PARTS AND SPECIAL TOOLS LIST**

---

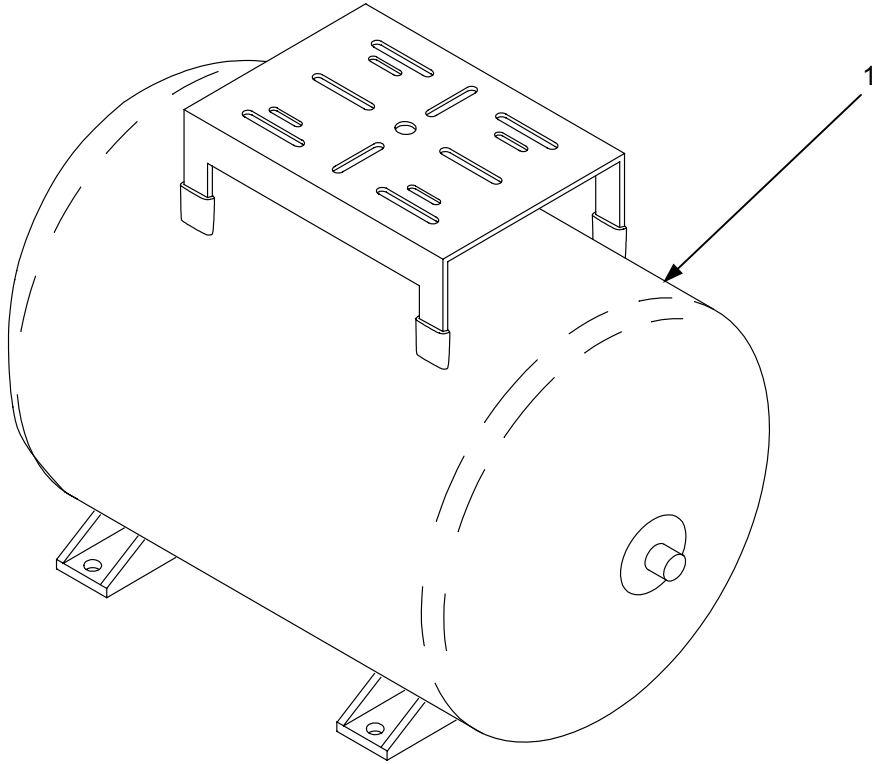

**Figure 9. Group 0302 Pressure Tank.**

(1) ITEM NO.	(2) SMR CODE	(3) NSN	(4) CAGEC	(5) PART NUMBER	(6) DESCRIPTION AND USABLE ON CODE (UOC)	(7) QTY
1			25795	4P833	GROUP 03 FRESHWATER SYSTEM GROUP 0302 PRESSURE TANK FIG. 9 PRESSURE TANK TEEL PRECHARGED WATER WELL TANK	1
END OF FIGURE						

END OF WORK PACKAGE

THIS PAGE INTENTIONALLY LEFT BLANK



THIS PAGE INTENTIONALLY LEFT BLANK

---

**GROUP 0303 PRESSURE SWITCH AND GAUGE  
REPAIR PARTS AND SPECIAL TOOLS LIST**

---

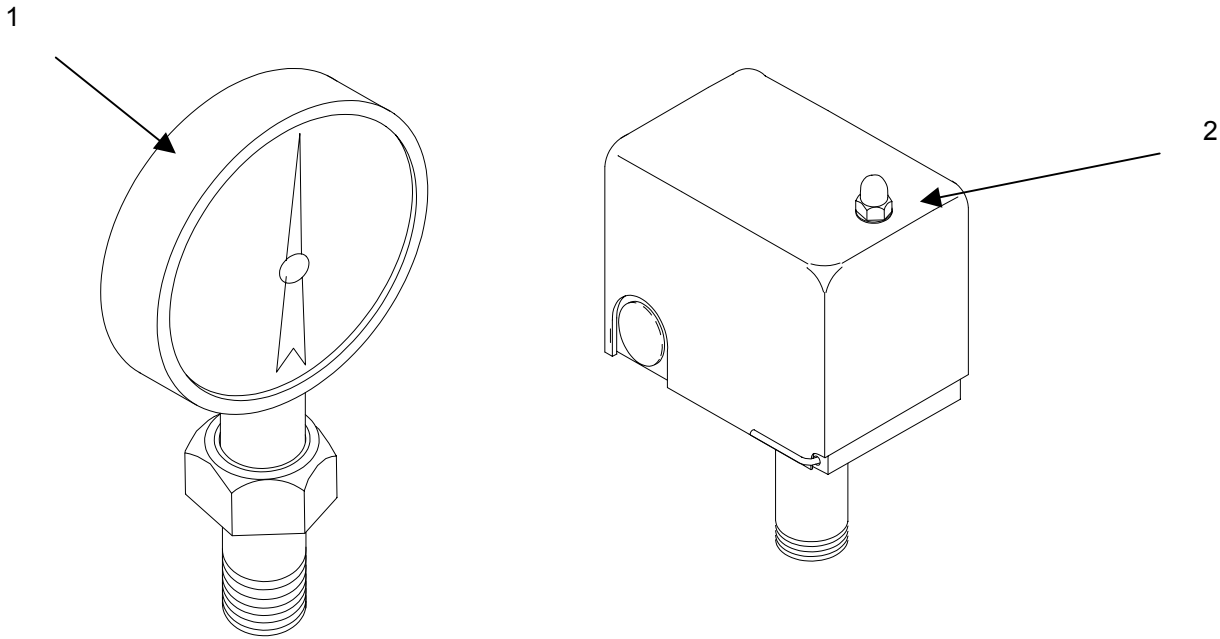

**Figure 10. Group 0303 Pressure Switch and Gauge.**

(1) ITEM NO.	(2) SMR CODE	(3) NSN	(4) CAGEC	(5) PART NUMBER	(6) DESCRIPTION AND USABLE ON CODE (UOC)	(7) QTY
					GROUP 03 FRESHWATER SYSTEM	
					GROUP 0303 PRESSURE SWITCH AND GAGE	
					FIG. 10 PRESSURE SWITCH AND GAGE	
1		6685-01-391-7560	39428	4023K14	0 -100 PSI / KPA PRESSURE GAUGE	1
2			56365	9013FSG 2M4	PRESSURE SWITCH	1
				END OF FIGURE		

END OF WORK PACKAGE

THIS PAGE INTENTIONALLY LEFT BLANK

THIS PAGE INTENTIONALLY LEFT BLANK

TM 10-3510-224-13&P  
GROUP 0401 SUMP PUMP  
REPAIR PARTS AND SPECIAL TOOLS LIST

0054 00

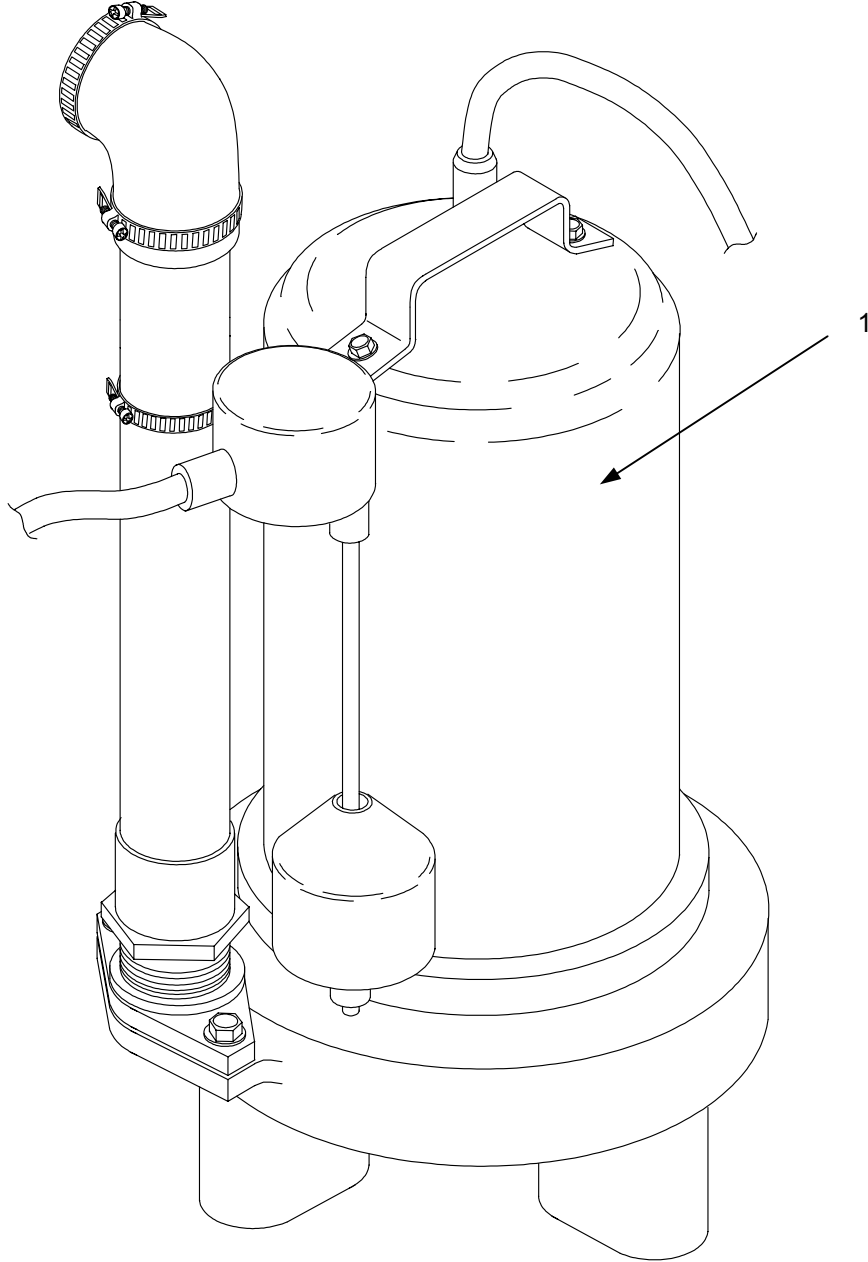

Figure 11. Group 0401 Sump Pump.

(1) ITEM NO.	(2) SMR CODE	(3) NSN	(4) CAGEC	(5) PART NUMBER	(6) DESCRIPTION AND USABLE ON CODE (UOC)	(7) QTY
					GROUP 04 TEEL SYMPLEX SEWAGEPACKAGE SYSTEM	
					GROUP 0401 SUMP PUMP	
					FIG. 11 SUMP PUMP	
1			25795	4NX02	SUMP PUMP	1
END OF FIGURE						

END OF WORK PACKAGE

THIS PAGE INTENTIONALLY LEFT BLANK



THIS PAGE INTENTIONALLY LEFT BLANK

TM 10-3510-224-13&P  
GROUP 0402 FLOAT SWITCH  
REPAIR PARTS AND SPECIAL TOOLS LIST

0055 00

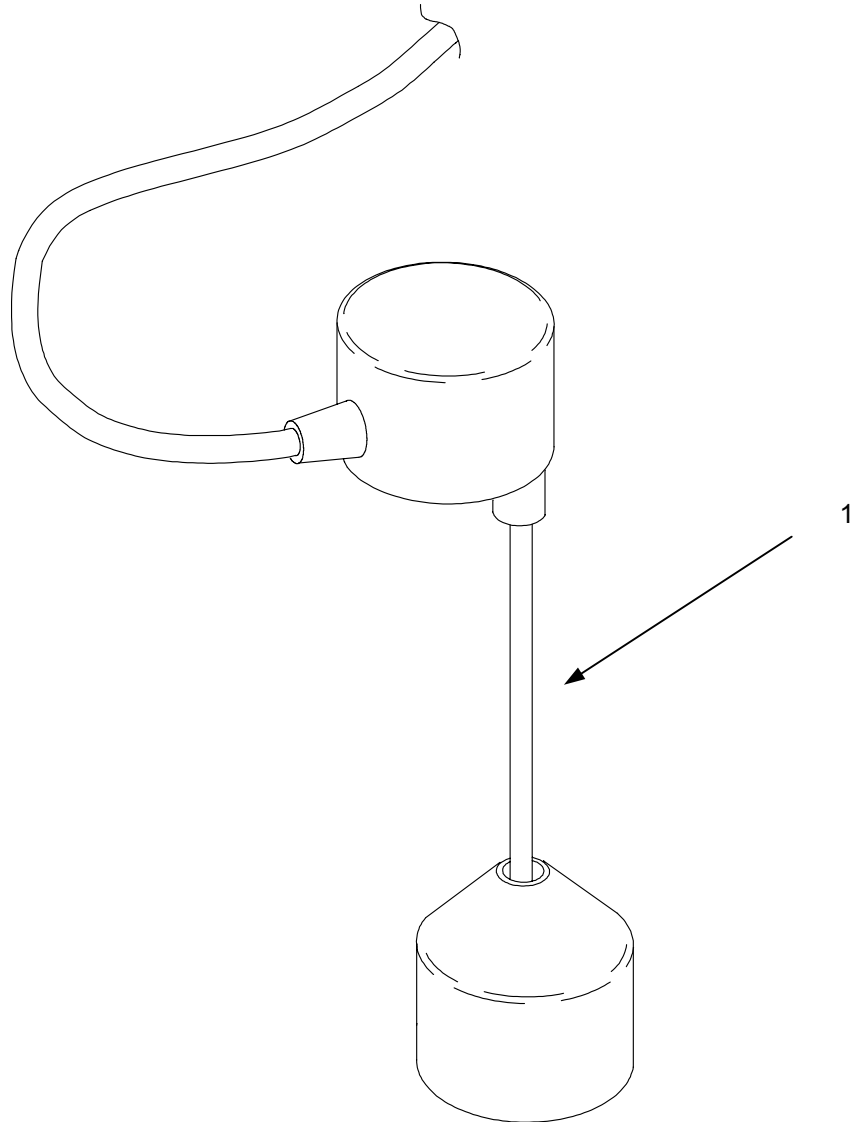

Figure 12. Group 0402 Float Switch.

(1) ITEM NO.	(2) SMR CODE	(3) NSN	(4) CAGEC	(5) PART NUMBER	(6) DESCRIPTION AND USABLE ON CODE (UOC)	(7) QTY
1			25795	4RJ46	GROUP 04 TEEL SYMPLEX SEWAGE PACKAGE SYSTEM  GROUP 0402 FLOAT SWITCH  FIG. 12 FLOAT SWITCH  FLOAT SWITCH	1
END OF FIGURE						

END OF WORK PACKAGE

THIS PAGE INTENTIONALLY LEFT BLANK

THIS PAGE INTENTIONALLY LEFT BLANK

**GROUP 0403 WASTEWATER PVC PIPES  
REPAIR PARTS AND SPECIAL TOOLS LIST**

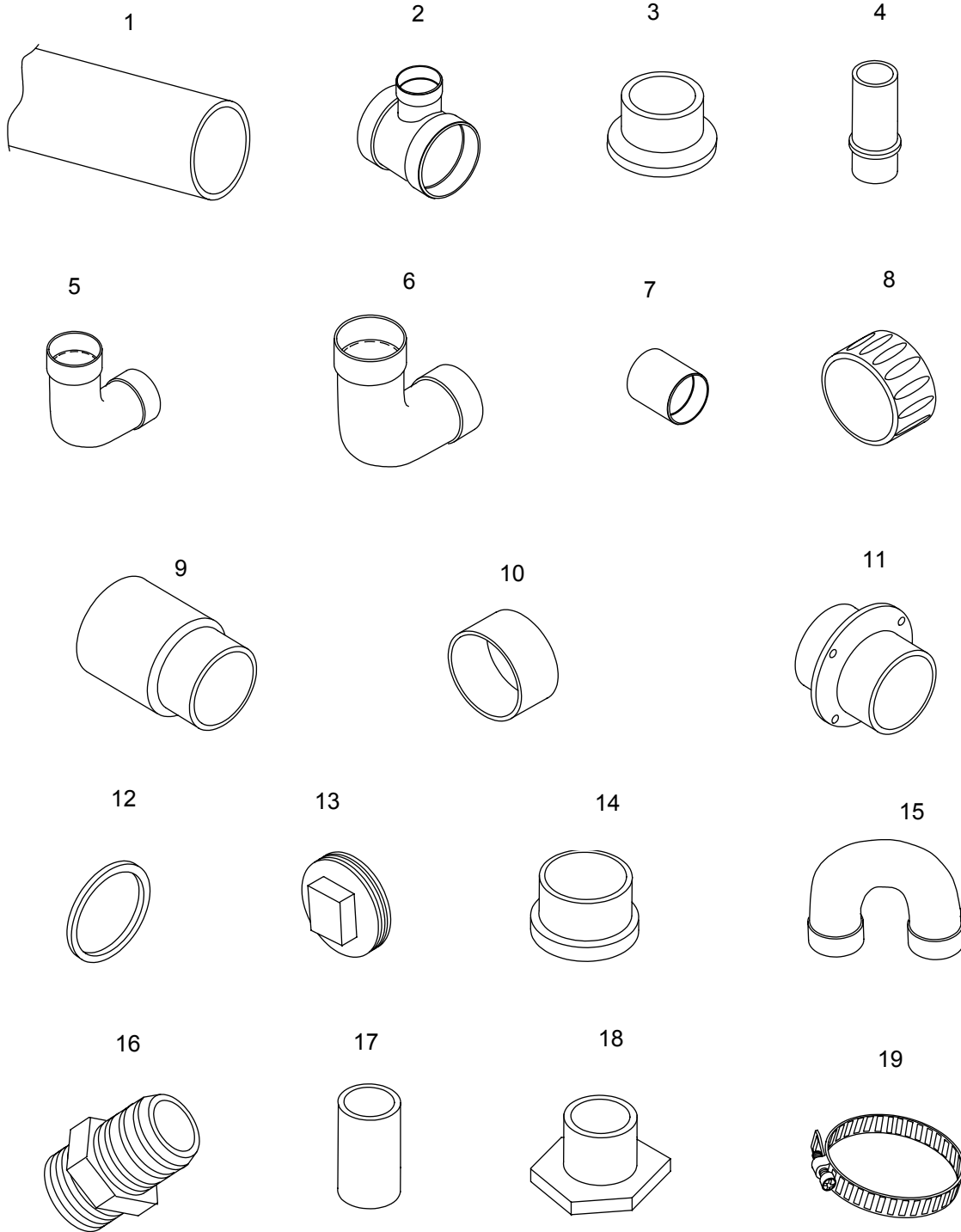

**Figure 13. Group 0403 Wastewater PVC Pipes.**

(1) ITEM NO.	(2) SMR CODE	(3) NSN	(4) CAGEC	(5) PART NUMBER	(6) DESCRIPTION AND USABLE ON CODE (UOC)	(7) QTY
					GROUP 04 TEEL SYMPLEX SEWAGEPACKAGE SYSTEM	
					GROUP 0403 WASTEWATER PVC PIPES	
1	PAFZZ		56879	70011	FIG. 12 WASTEWATER PVC PIPES PIPE, SCHEDULE 40, PVC-DWV, NS 1.50 INCH DIAMETER	1
2	PAFZZ		56879	61131	FITTING, REDUCING, SANITARY, TEE SCHEDULE 40, PVC, 3" x 3" x 1.5"	8
3	PAFZZ		56879	34257	FITTING, REDUCING, 1.5" x .75"	6
4	PAFZZ		56879	350407	FITTING, INSERTMALE, ADAPTER .75"	6
5	PAFZZ		56879	72820	FITTING, 90° SANITARY, ELBIW, 2.00"	2
6	PAFZZ		56879	72830	FITTING, 90° SANITARY, ELBOW, 3.00"	2
7	PAFZZ		56879	70320	FITTING, FEMALE ADAPTER, SCHEDULE 40, PVC-DWV, 2" x 2"	1
8	PAFZZ		56879	37220	FITTING, IPS UNION, SCHEDULE 40, PVC-DWV, 2"	1
9	PAFZZ		56879	60430	FITTING, MALE ADAPTER SCHEDULE 40, PVC 3" x 3"	1
10	PAFZZ		56879	60330	FITTING, FEMALE ADAPTER SCHEDULE 40, PVC 3" x 3"	1
11	PAFZZ		56879	5-13-6594	COUPLING, WASTEWATER PANEL	1
12	PAFZZ		56879	5-13-6622	GASKET, WASTEWATER TANK	2
13	PAFZZ		56879	61630	FITTING, CLEANOUT WITH THREADED PLUG, 3"	1
14	PAFZZ		56879	70420	FITTING, ADAPTER, MALE, 2" x 2"	1
15	PAFZZ		62579	700 1 1/2	ELBOW, 180 DEGREE, SCHEDULE 40, PVC	6
16	PAFZZ		39428	48315K94	BARBED PVC FITTING, 1 ¼" NPT, MALE ADAPTER	6
17	PAFZZ		56879	70011	PIPE, SCHEDULE 40, PVC 1 ½" x 3"	6
18	PAFZZ		39428	4880K211	ADAPTER, THREADED, 1 ½" x 1 ¼" SCHEDULE 40, PVC	6
19	PAFZZ	4730-01-360-3222	39428	5661K12	HOSE CLAMP, 1.75-2.26, WORM DRIVE	6
END OF FIGURE						

END OF WORK PACKAGE

THIS PAGE INTENTIONALLY LEFT BLANK



THIS PAGE INTENTIONALLY LEFT BLANK

TM 10-3510-224-13&P  
GROUP 05 WASHER/DRYER  
REPAIR PARTS AND SPECIAL TOOLS LIST

0057 00

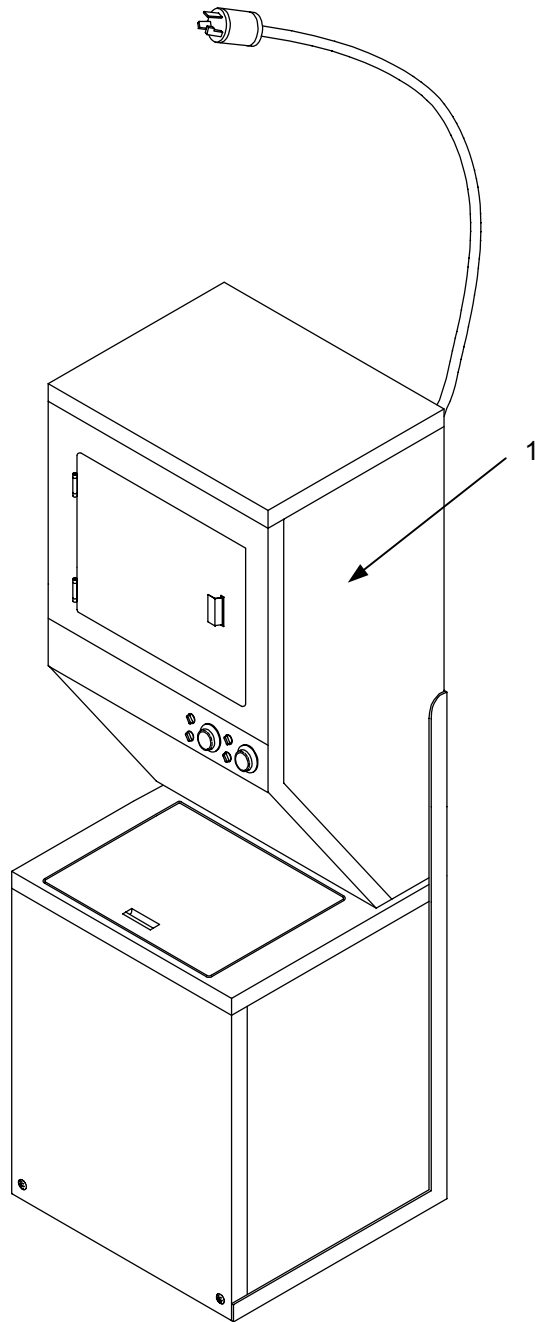

Figure 14. Group 05 Washer/Dryer.

(1) ITEM NO.	(2) SMR CODE	(3) NSN	(4) CAGEC	(5) PART NUMBER	(6) DESCRIPTION AND USABLE ON CODE (UOC)	(7) QTY
					GROUP 05 WASHER/DRYER	
					FIG. 13 WASHER/DRYER	
1			39089	LSE7806ACE	MAYTAG WASHER AND DRYER	6
END OF FIGURE						

END OF WORK PACKAGE

THIS PAGE INTENTIONALLY LEFT BLANK

THIS PAGE INTENTIONALLY LEFT BLANK

TM 10-3510-224-13&P  
GROUP 06 VENT FAN  
REPAIR PARTS AND SPECIAL TOOL LIST

0058 00

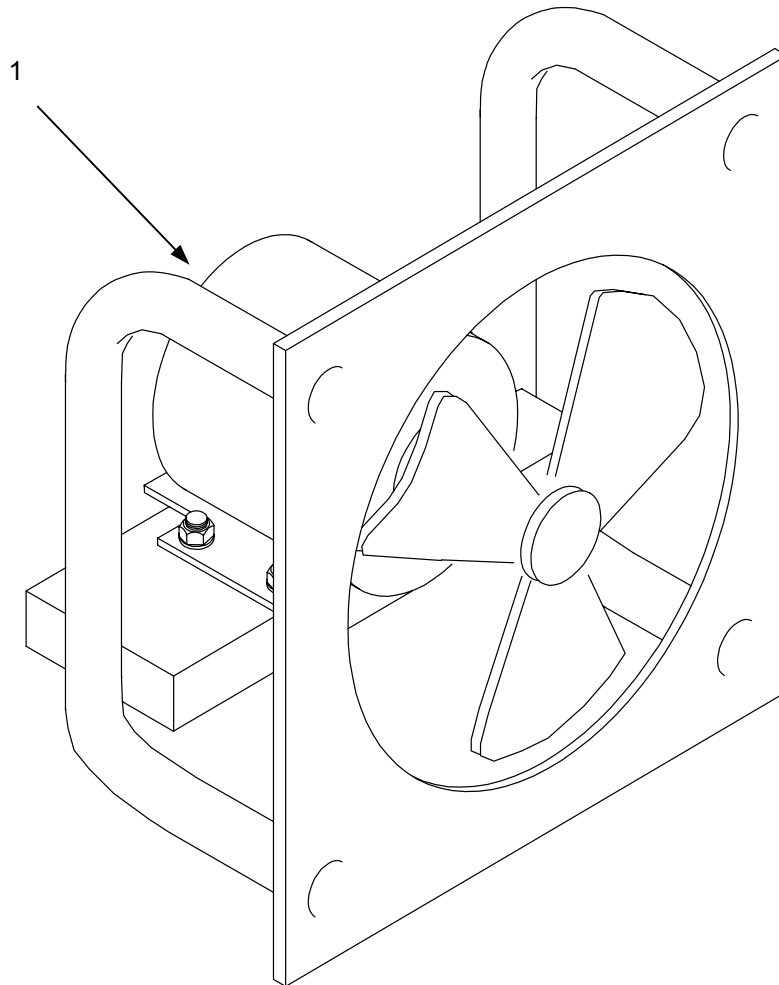

Figure 15. Group 06 Vent Fan.

(1) ITEM NO.	(2) SMR CODE	(3) NSN	(4) CAGEC	(5) PART NUMBER	(6) DESCRIPTION AND USABLE ON CODE (UOC)	(7) QTY
					GROUP 06 VENT FAN ASSEMBLY	
					FIG. 14 VENT FAN ASSEMBLY	
1			81337	3K355A	MOTOR	1
END OF FIGURE						

END OF WORK PACKAGE

THIS PAGE INTENTIONALLY LEFT BLANK



THIS PAGE INTENTIONALLY LEFT BLANK

GROUP 07 TEMPER  
REPAIR PARTS AND SPECIAL TOOLS LIST

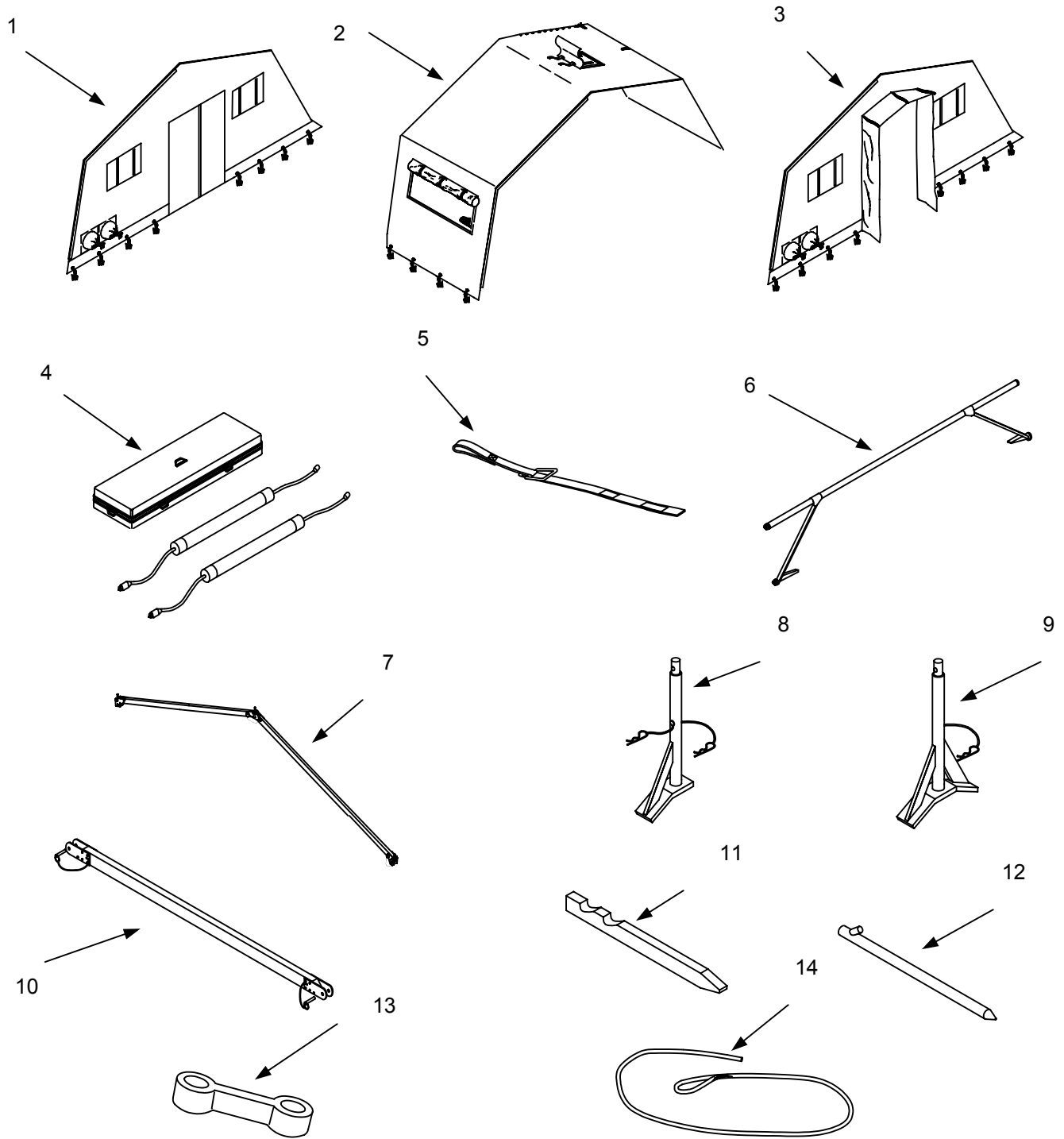

Figure 16. Group 07 TEMPER Sections.

(1) ITEM NO.	(2) SMR CODE	(3) NSN	(4) CAGEC	(5) PART NUMBER	(6) DESCRIPTION AND USABLE ON CODE (UOC)	(7) QTY
					GROUP 07 TEMPER	
					FIG. 15 TEMPER Sections	
1	PAFZZ	8340-01-186-3014	81337		TEMPER END SECTION	1
2	PAFZZ	8340-01-186-3021	81337		TEMPER, WINDOW SECTION	1
3	PAFZZ		81337	9-1-0560	TEMPER END SECTION, MODIFIED	1
4	PAFZZ	6320-01-465-8931			LIGHT SET, GENERAL ILLUMINATION	1
5	PAOZZ	8465-01-220-1419	81337	50404005	STRAP, LIGHT SUPPORT ASSEMBLY, TYPE 1	4
6	PAFZZ	8340-01-186-3005	81337	5-4-3336	PURLIN ASSEMBLY	5
7	PAFZZ	8340-01-240-5854	81337	5-4-4006	ARCH ASSEMBLY	2
8	PAFZZ	8340-01-186-3009	81337	5-4-3341	EAVE EXTENDER	4
9	PAFZZ	8340-01-186-3008	81337	5-4-3340	RIDGE EXTENDER	1
10	PAFZZ	8340-01-186-3004	81337	5-4-3335	HEADER ASSEMBLY	2
11	PAOZZ	8340-00-261-9751	81337	5-4-1	TENT PIN, WOOD, 24"	6
12	PAOZZ	8340-00-823-7451	81337	5-4-791	TENT PIN, STEEL, 12"	24
13	PAOZZ	8340-00-205-2759	81337		SLIP, TENT LINE	6
14	PAOZZ	8340-00-252-2273	81337		LINE, TENT	6
END OF FIGURE						

END OF WORK PACKAGE

THIS PAGE INTENTIONALLY LEFT BLANK

THIS PAGE INTENTIONALLY LEFT BLANK

---

TM 10-3510-224-13&P  
GROUP 08 SPACE HEATER  
REPAIR PARTS AND SPECIAL TOOLS LIST

---

0060 00

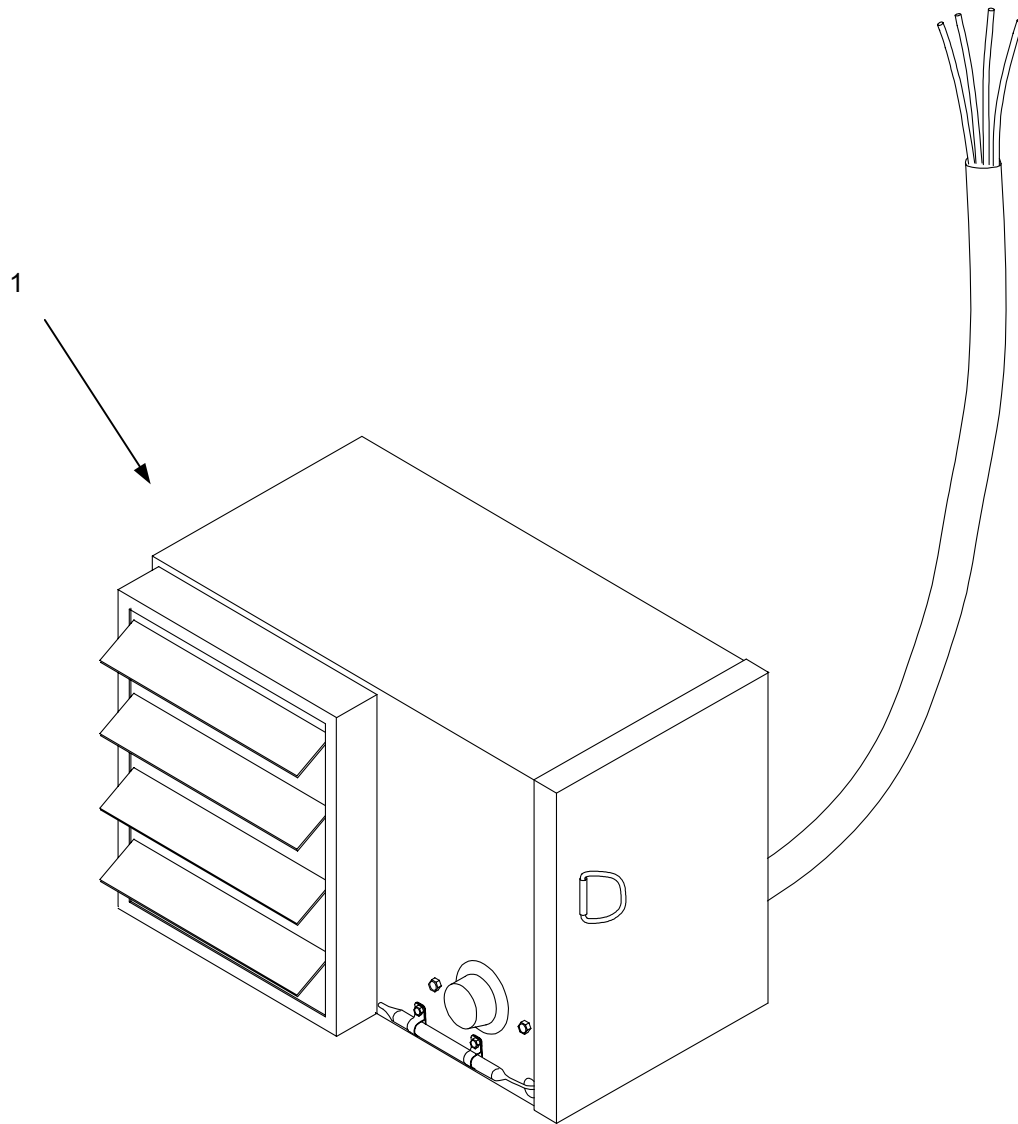

Figure 17. Group 08 Space Heater.

(1) ITEM NO.	(2) SMR CODE	(3) NSN	(4) CAGEC	(5) PART NUMBER	(6) DESCRIPTION AND USABLE ON CODE (UOC)	(7) QTY
					GROUP 08 SPACE HEATER	
					FIG. 16 SPACE HEATER	
1			53715	82UH10C0T03	HEATER, 208 VOLTS, 3 PHASE	1
END OF FIGURE						

END OF WORK PACKAGE

THIS PAGE INTENTIONALLY LEFT BLANK



THIS PAGE INTENTIONALLY LEFT BLANK

TM 10-3510-224-13&P  
GROUP 09 3,000 GALLON WATER TANK  
REPAIR PARTS AND SPECIAL TOOLS LIST

0061 00

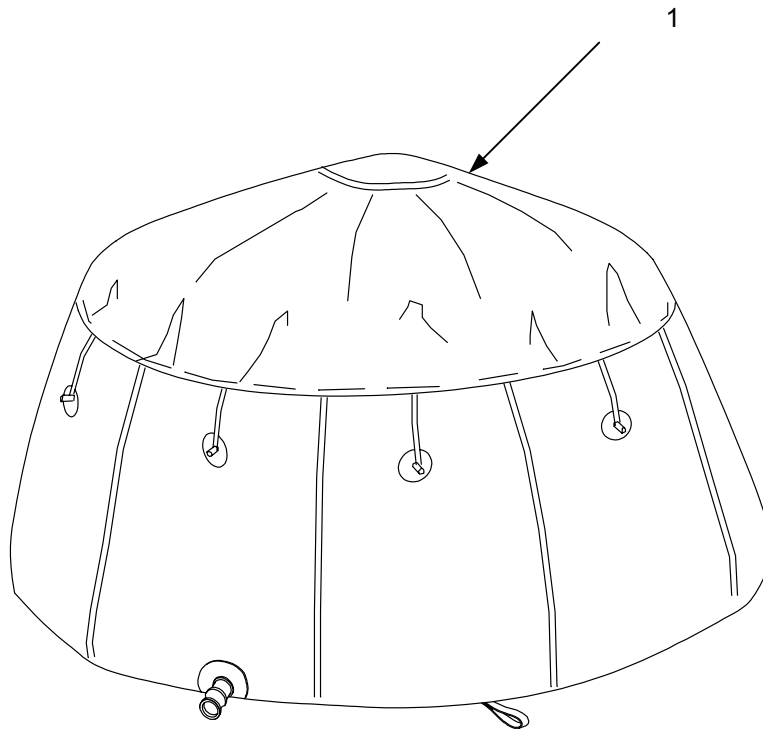

Figure 18. Group 09 3,000 Gallon Tank.

(1) ITEM NO.	(2) SMR CODE	(3) NSN	(4) CAGEC	(5) PART NUMBER	(6) DESCRIPTION AND USABLE ON CODE (UOC)	(7) QTY
1	PAFZZ	5430-01-470-7380			GROUP 09 3,000 GALLON TANK  FIG. 17 3,000 GALLON TANK TANK, FABRIC, SEALED TOP, 3,000 GALLON, WATER	2
END OF FIGURE						

END OF WORK PACKAGE

THIS PAGE INTENTIONALLY LEFT BLANK

THIS PAGE INTENTIONALLY LEFT BLANK

TM 10-3510-224-13&P  
GROUP 10 WATER HOSES  
REPAIR PARTS AND SPECIAL TOOLS LIST

0062 00

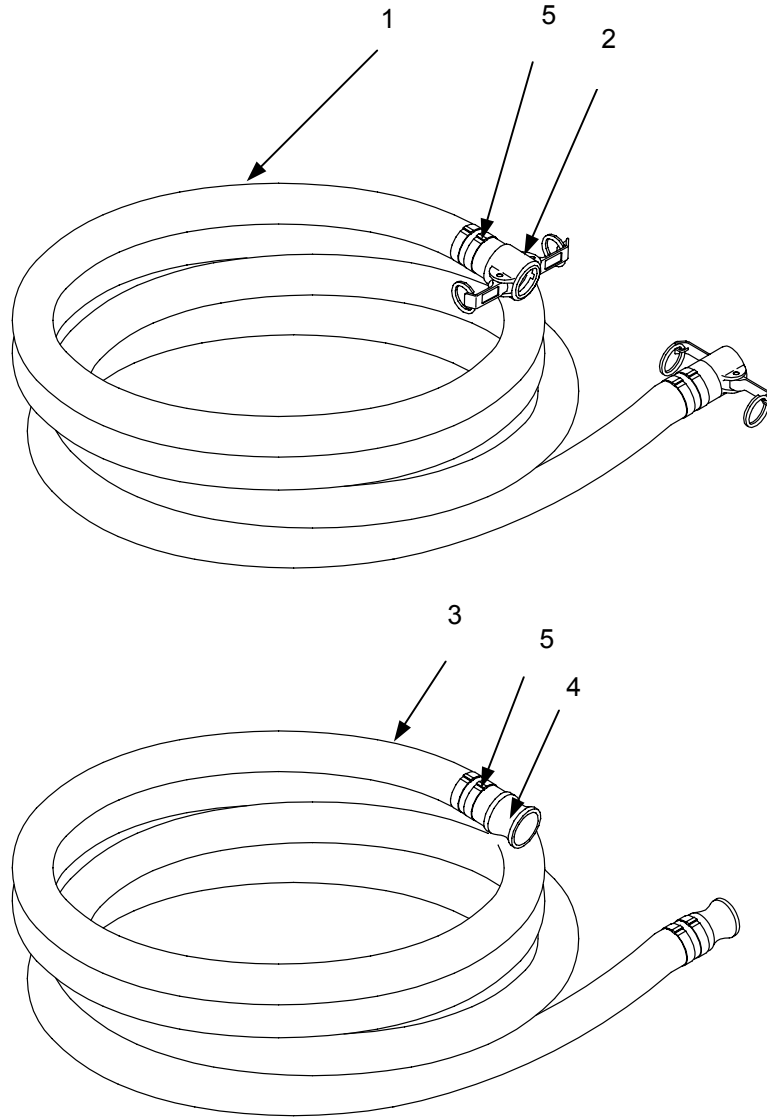

Figure 19. Group 10 Water Hoses.

(1) ITEM NO.	(2) SMR CODE	(3) NSN	(4) CAGEC	(5) PART NUMBER	(6) DESCRIPTION AND USABLE ON CODE (UOC)	(7) QTY
					GROUP 10 WATER HOSES	
1	PAFZZ		81337	5-13-6635	FIG. 18 WATER HOSES HOSE 2", 20 FOOT, FRESH WATER	1
2	PAFZZ		39428	51415K35	C-COUPLER, HOSE SHANK AND COUPLER SIZE 2 IN 250 PSI	2
3	PAFZZ		81337	5-13-6636	HOSE 2", 20 FOOT, WASTE WATER	1
4	PAFZZ		39428	51415K65	E-ADAPTER, ADAPTER AND HOSE SHANK SIZE 2 IN 250 PSI	2
5	PAFZZ		39428	5661K12	HOSE CLAMP 1.75-2.62 WORMDRIVE	4
				END OF FIGURE		

END OF WORK PACKAGE

THIS PAGE INTENTIONALLY LEFT BLANK



THIS PAGE INTENTIONALLY LEFT BLANK

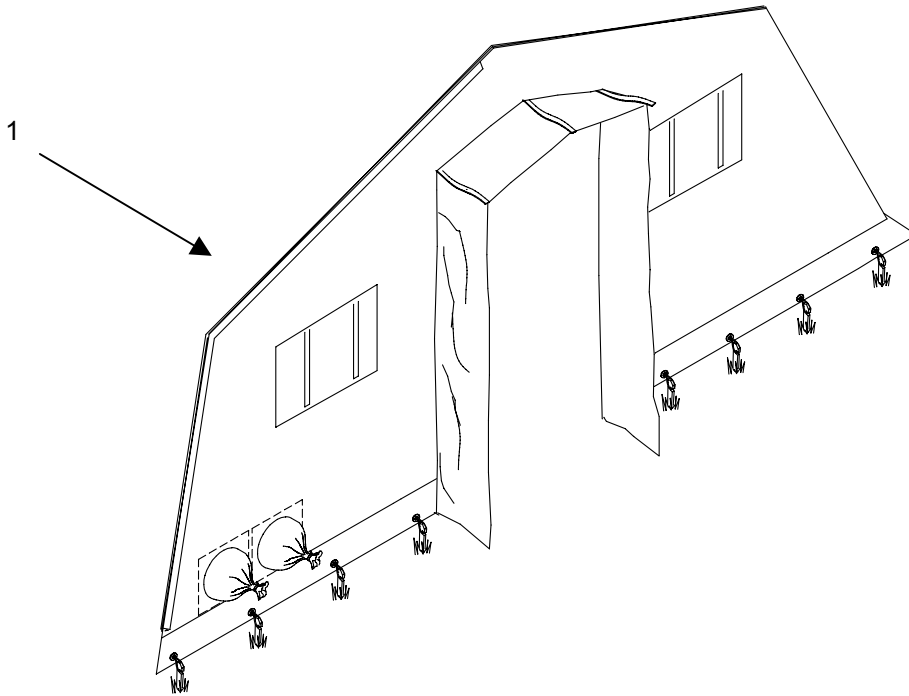

Figure 20. Group 11 CSSL Modified End Section.

(1) ITEM NO.	(2) SMR CODE	(3) NSN	(4) CAGEC	(5) PART NUMBER	(6) DESCRIPTION AND USABLE ON CODE (UOC)	(7) QTY
					GROUP 11 TEMPER MODIFIED END SECTION	
					FIG. 19 TEMPER MODIFIED END SECTION	
1			81337	9-1-0560	TEMPER ISO MODIFIED END SECTION	
				END OF FIGURE		

END OF WORK PACKAGE

THIS PAGE INTENTIONALLY LEFT BLANK

CONTAINERIZED SELF SERVICE LAUNDRY (CSSL)

NSN 3510-01-485-0457

BULK MATERIAL REPAIR PARTS LIST

(1) ITEM NO.	(2) SMR CODE	(3) NSN	(4) CAGEC	(5) PART NUMBER	(6) DESCRIPTION AND USABLE ON CODE (UOC)	(7) QTY
					GROUP 11 BULK MATERIAL	
1	MOOZZ		56879	70031	Pipe, Schedule 40, PVC-DWV Nominal Size: 3" Diameter	AR
2	MOOZZ		56879	70021	Pipe, Schedule 40, PVC-DWV Nominal Size: 2" Diameter	AR
3	MOOZZ		56879	70011	Pipe, Schedule 40, PVC-DWV Nominal Size: 1.5" Diameter	AR
4	MOOZZ		81346	Type L	Seamless Copper Water Tube Nominal Size 3/4"	AR
5	MOOZZ		81346	Type L	Seamless copper Water Tube Nominal Size 1/2"	AR
6	MOOZZ		81349	M22759/16-12-5	Wire, Electric Fluoropolymer Insulated	
				END OF FIGURE		

END OF WORK PACKAGE

THIS PAGE INTENTIONALLY LEFT BLANK.

---

CONTAINERIZED SELF SERVICE LAUNDRY (CSSL)  
NSN 3510-01-485-0457  
NATIONAL STOCK NUMBER INDEX

---

STOCK NUMBER	FIG.	ITEM
8115-01-341-7524	1	1
5340-01-170-6984	16	1

END OF WORK PACKAGE

THIS PAGE INTENTIONALLY LEFT BLANK



---

**CONTAINERIZED SELF SERVICE LAUNDRY (CSSL)  
NSN 3510-01-485-0457  
SPECIAL TOOLS LIST**

---

<b>NATIONAL STOCK NUMBER</b>	<b>FIG</b>	<b>ITEM</b>
------------------------------	------------	-------------

There are no special tools required for the CSSL or its associated equipment.

**END OF WORK PACKAGE**

THIS PAGE INTENTIONALLY LEFT BLANK

---

**CONTAINERIZED SELF SERVICE LAUNDRY (CSSL)**  
**NSN 3510-01-485-0457**  
**PART NUMBER INDEX**

---

<b>PART NUMBER</b>	<b>FIG.</b>	<b>ITEM</b>
MIL-C-52661	1	1
5-13-6630	2	1
MS35307-334		2
MS90558C44421P	3	1
MS51958-81		2
MS51958-82		3
MS15795-858		4
MS21044C4		5
MS90555C324135		6
MS51958-81		7
MS51958-82		8
MS15795-846		9
MS21044C3		10
WPFS26		11
MS51960-67		12
6899		13
MS21043-06		14
MS39347-4		15
MS35338-143		16
MS51969		17
MS51969-5		18
HBL2516		19
NQOD430M100CU	4	1
PK18GTA-L		2
QOFP		3
QOB115		4
QOB360		5
QOB230		6
QOB315		7
QOB310		8
5-13-6627-2		9
5-13-6624-2		10
6F555	5	1
MT91505		2
3V477		3
A720	6	1
2710A		2
CS1 15W		3

A1		4
05226001		5
SC-D-883964 GP9-3	7	1
4RJ54	8	1
4429K427		2
4568K271		3
4568K268		4
4568K131		5
4568K142		6
4568K196		7
4568K192		8
4568K211		9
5520K72		10
5520K12		11
73605T59		12
5520K509		13
XXX		14
200678		15
50475K25		16
90294A315		17
4023K14		18
9013FSG 2M4		19
5520K52		20
4429K164		21
73605T57		22
4429K216		23
4429K254		24
1A532		25
4429K461		26
4568K191		27
4429K218		28
4429K255		29
MS27026		30
MS27029		31
4568K222		32
4568K261		33
4429K215		34
43935K27		35
4385K34		36

5-13-6649		37
4568K191		38
47865K23		39
47865K21		40
4616K95		41
4P633	9	1
4023K14	10	1
9013FSG 2M4		2
4NX02	11	1
70011	12	1
61131		2
34257		3
350407		4
72820		5
72830		6
70320		7
37220		8
70320		9
60430		10
60330		11
5-13-6594		12
5-13-6622		13
61630		14
70420		15
LSE7806ACE	13	1
3K355A	14	1
8340-01-185-2618	15	1
82UH10	16	1
5430-01-170-6984	17	1
5-13-6635	18	1
5141K35		2
5-13-6636		3
5141K65		4
5861K12		5
9-1-0560	19	1

**END OF WORK PACKAGE**

THIS PAGE INTENTIONALLY LEFT BLANK

---

**CONTAINERIZED SELF SERVICE LAUNDRY (CSSL)  
COMPONENTS OF END ITEM AND BASIC ISSUE ITEMS LIST**

---

**Introduction.**

**Scope.** This section lists COEI and BII for the CSSL to help you inventory items for safe and efficient operation of the equipment.

**General.** The COEI and BII information is divided into the following lists:

Components of End Item (COEI). This list is for information purposes only and is not authority to requisition replacements. These items are part of the CSSL. As part of the end item, these must be with the end item whenever it is issued or transferred between property accounts. Items of COEI are removed and separately packaged for transportation or shipment only when necessary. Illustrations are furnished to help you find and identify the items.

Basic Issue Items (BII). These essential items are required to place the CSSL in operation, operate it, and to do emergency repairs. Although shipped separately packaged, BII must be with the CSSL during operation and when it is transferred between property accounts. Listing these items is your authority to request / requisition them for replacement based on authorization of the end item by the TOE/MTOE. Illustrations are furnished to help you find and identify the items.

Explanation of Columns in the COEI List and BII List.

Column 1, Illus Number, gives you the number of the item illustrated.

Column 2, National Stock Number, identifies the stock number of the item to be used for requisitioning purposes.

Column 3, Description, CAGEC, and Part Number, identifies the Federal item name (in all capital letters) followed by a minimum description when needed. The last line below the description is the CAGEC (commercial and Government entity code) (in parenthesis) and the part number.

Column 4, Usable on code, gives you a code if the item you need is not the same for different models of equipment. There is no usable on code for the CSSL.

Column 5, UM (unit of measure), indicates how the item is issued for the National Stock Number shown in column 2.

Column 6, Qty Rqr, indicates the quantity required.

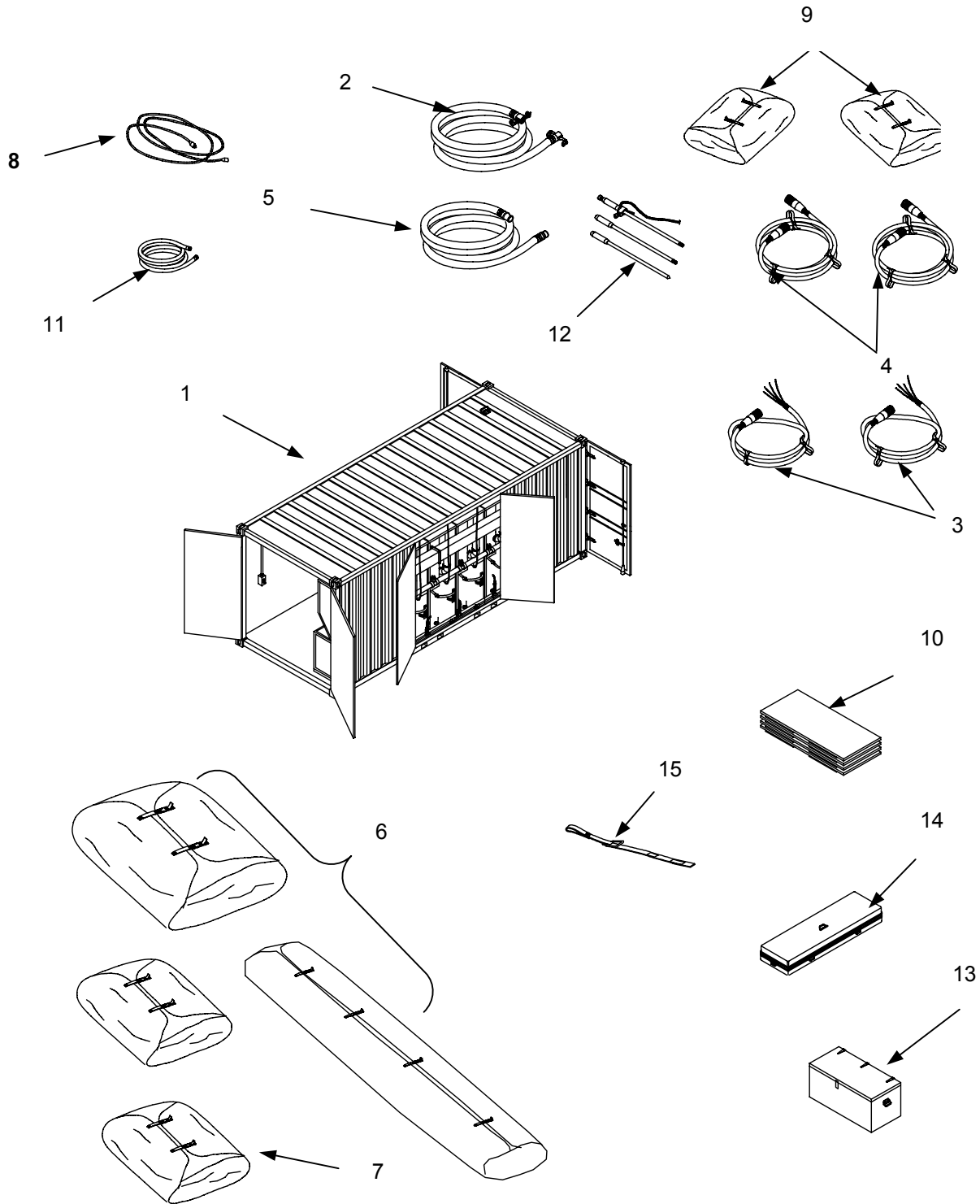

Components of End Item.



Table-1. Components of End Item List.

(1) ILLUS NUMBER	(2) NATIONAL STOCK NUMBER	(3) DESCRIPTION, LOCATION, PART NUMBER, AND (CAGEC)	(4) USABLE ON CODE	(5) U/M	(6) QTY RQR
1	8115-01-341-7524	Container, Modified, Welded Assembly, 5-13-6538 (81337).		EA	1
2		Hose Assembly, Fresh Water, 5-13-6635 (81337).		EA	1
3	13227E7020	100 AMP Cable/Pigtail, 13227E7024.		EA	2
4		Hose Assembly, Discharge, Waste Water, 5-13-6636 (81337).		EA	1
5	8340-01-186-3021	TEMPER Window Section / Frame Components.		EA	1
6		TEMPER Modified End Section 9-1-0506 (81337).		EA	1
7	8340-01-186-3014	TEMPER End Section.		EA	1
8		Extension Cord.		EA	1
9	5340-01-470-7380	3000 Gallon Fabric Water Tank, Sealed Top.		EA	2
10	7105-00-269-9275	Table, Folding Legs.		EA	4
11	4720-00-729-5334	Garden Hose.		EA	1
12	5975-00-676-3791	Grounding Rod Assembly, Sectional, w/Attachments.		EA	1
13	8460-00-243-3234	Footlocker.		EA	1
14	6320-01-465-8931	Light Set, General Illumination.		EA	1
15		Strap, Tiedown Assembly, 5-13-6618 (81337).		EA	5

Table-2. Basic Issue Items List.

(1) ILLUS NUMBER	(2) NATIONAL STOCK NUMBER	(3) DESCRIPTION, PART NUMBER AND CAGEC	(4) USABLE ON CODE	(5) U/M	(6) QTY RQR
1	N/A	TM 10-3510-224-13&P		EA	1

1

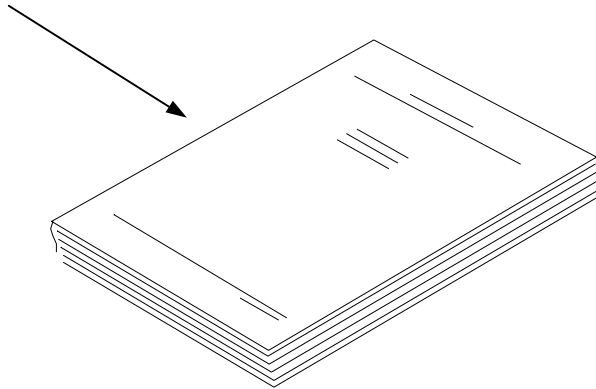

END OF WORK PACKAGE

**CONTAINERIZED SELF SERVICE LAUNDRY (CSSL)  
ADDITIONAL AUTHORIZATION LIST (AAL)**

**Introduction.**

**Scope.** This section lists additional items you are authorized for the support of the CSSL.

**General.** This list identifies items that do not have to accompany the CSSL and that do not have to be turned in with it. These items are all authorized to you by CTA, MTOE, TDA, or JTA.

Explanation of Columns in the AAL:

Column (1), Item Number.

Column (2), National Stock Number, identifies the stock number of the item to be used for requisitioning purposes.

Column (3), Description, CAGEC, and Part Number, identifies the Federal Item Name (in all capital letters) followed by a minimum description when needed. The last line below the description is the CAGE (Commercial and Government Entity Code) (in parenthesis) and the part number.

Column (4), Usable On Code, when applicable, gives you a code if the item you need is not the same for different models of equipment.

Column (5), UM (unit of measure) indicates how the item is issued for the National Stock Number shown in column (2).

Column (6), Qty Recm, indicates the quantity recommended.

**ADDITIONAL AUTHORIZED ITEMS LIST.**

**Table 1. Additional Authorization List.**

(1) ITEM NUMBER	(2) NATIONAL STOCK NUMBER	(3) DESCRIPTION, (CAGEC) AND PART NUMBER	(4) USABLE ON CODE	(5) U/M	(6) QTY RECM
1	4210-01-165-4703	Fire Extinguisher		EA	1
2	6230-00-163-1856	Flashlight		EA	1
3	5120-00-764-8058	Screwdriver, Flat tip		EA	1

THIS PAGE INTENTIONALLY LEFT BLANK

**CONTAINERIZED SELF SERVICE LAUNDRY (CSSL)  
EXPENDABLE AND DURABLE ITEMS LIST**

**Introduction.**

This section lists expendable and durable items that you will need to operate and maintain the CSSL. This list is for information only and is not authority to requisition the listed items. These items are authorized to you by CTA 50-970, Expendable/Durable Items (Except Medical, Class V Repair Parts, and Heraldic Items), or CTA 8-100, Army Medical Department Expendable/Durable Items.

**Explanations of Columns in the Expendable / Durable Items List.**

Column (1,) Item Number. This number is assigned to each entry in the list and is referenced in the narrative instructions to identify the item (e.g. Use wiping rags (WP 0070, Table 1, Item 1).

Column (2), Level. This column includes the lowest level of maintenance that requires the listed item.

- C** Operator or Crew
- O** Unit Maintenance
- F** Direct Support Maintenance
- H** General Support Maintenance
- D** Depot Maintenance

Column (3), National Stock Number. This is the NSN assigned to the item that you can use to requisition it.

Column (4,) Item Name, Description, CAGEC, and Part Number. This column provides the other information you need to identify the item.

Column (5), U/M (unit of measure). This indicates how the item is issued for the National Stock Number shown in column (1).

**Expendable and Durable Items List.**

**Table 1. Expendable and Durable Items List.**

(1) ITEM NUMBER	(2) LEVEL	(3) NATIONAL STOCK NUMBER	(4) ITEM NAME, DESCRIPTION, (CAGEC), PART NUMBER	(5) U/M
1	O, F	7920-00-205-3570	Wiping Rags	LB
2	O, F		Light Fluorescent General Purpose, 48" (2F367) 3V477	EA
3	F		Tape, Antiseize (58536) AA56092-2-2	RL
4	F		Solder, Lead Free, (OJ940), 14-7080-0125	LB
5	O	5970-00-644-3167	Tape, (58536)	RL
6	F		Cement, All-Purpose, PVC Piping, (56879), 15010	LB
7	F		Cleaner, All-Purpose, PVC Piping, (56879), 2X318	LB
8	F	9905-00-537-8954	Tags, Marking	HD
9	O	7920-00-291-8305	Broom	EA
10	O	7920-00-267-1218	Mop Handle	EA

Table 1. Expendable and Durable Items List-Continued.

(1) ITEM NUMBER	(2) LEVEL	(3) NATIONAL STOCK NUMBER	(4) ITEM NAME, DESCRIPTION, (CAGEC), PART NUMBER	(5) U/M
11	O	7920-00-141-5550	Mop Head	EA
12	O	7240-00-161-1143	Trash Can	EA
13	F	5970-00-644-3167	Tape, Electrical Insulation, 3/4 inch width	RL
14	F		Clamp, Loop, Plastic Wire Support (96906) MS25281-R10	EA
15	O, F		Hose Clamp 1.75-2.62, Wormdrive (39428) 5661k12	EA
16	O	7510-00-053-0942	Tape, Pressure Sensitive	RL
17			V-Belt, Drive (0GAZ1) 211124	1
18			V-Belt, Pump (0GAZ1) 211125	1
19	O	5330-00-612-2414	Gasket, Buna-N Rubber, 2"	EA

END OF WORK PACKAGE

---

**CONTAINERIZED SELF SERVICE LAUNDRY (CSSL)  
MANDATORY REPLACEMENT PARTS LIST**

---

**Introduction.**

**Scope.** This work package includes a list of all mandatory replacement parts referenced in the task initial setups and procedures. These are items that must be replaced during maintenance whether they have failed or not. This includes items based on usage intervals such as miles, time, rounds fired, etc.

**Mandatory Replacement Parts List.**

There are no mandatory replacement parts for the CSSL.

**END OF WORK PACKAGE**

THIS PAGE INTENTIONALLY LEFT BLANK



---

**CONTAINERIZED SELF SERVICE LAUNDRY (CSSL)**  
**NSN 3510-01-485-0457**  
**ILLUSTRATED LIST OF MANUFACTURED ITEMS**

---

**Introduction.**

**Scope.** This work package contains complete instructions for making items authorized to be manufactured or fabricated at the direct support maintenance level.

**How to use the Index of Manufactured Item.** The part number index below is organized in alphanumeric order. It is provided for cross-referencing the part number of the item to be manufactured to the figure that covers its fabrication procedures.

**Explanation of the Illustrations of Manufactured Items.** All instructions needed by maintenance personnel to manufacture the item are included on the figures. Refer to the RPSTL work package 0042 00 for further information about manufactured items. Bulk materials needed for manufacture of an item are listed by part number, or specification number in a tabular listing on the illustration.

**Safety Warnings and Cautions.** Follow the warnings and cautions in this work package as well as the respective work packages containing the direct support repair / replace procedure for the item.

**INDEX OF MANUFACTURED ITEMS.**

<b>Part Number</b>	<b>Description</b>	<b>Figure Number</b>
LSE7806ACE	Washer/Dryer	Figure 1
82UN10	Heater	Figure 2
4NX02	Sump Pump	Figure 3

**Figure 1.**

Power Cord Assembly / Attachment, Washer/Dryer.

**WARNING**

Ensure that only specified materials are used in the construction of the power cord. Install new cord completely before applying power to the appliance. Serious injuries or electrocution could result.

**NOTES:**

1. Fabricate a new cord from the materials specified and to the dimensions shown in the following drawing.
2. Mark the cord as shown in the table
3. Connect the new cord to the Washer/Dryer and plug as shown in the following drawing.
4. Enter the manufacturer's CAGE Code in accordance with MIL-STD-130.
5. Remove the terminal block cover. Remove the ground strap screw from the terminal block support. Fold the ground strap over so both ends of the ground strap are attached to the center post. Connect the neutral (white) wire of the power supply cord to the center (silver) terminal of the terminal block. Connect the grounding wire (green) of the cord to the terminal block support using the ground strap screw. Connect the other two wires of the cord to terminals L1 and L2 as shown.
6. Securely crimp the terminal lugs to the conductors. Terminal lugs shall not separate from the conductors when subjected to a pull out load of 8 pounds.

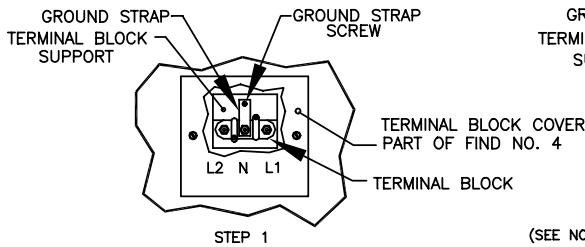
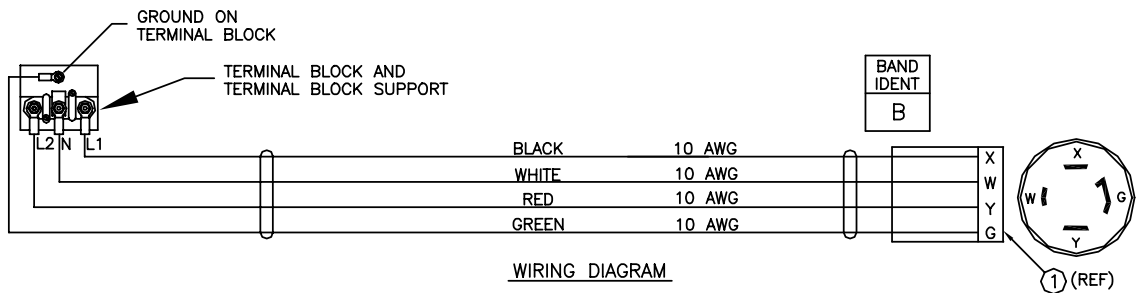
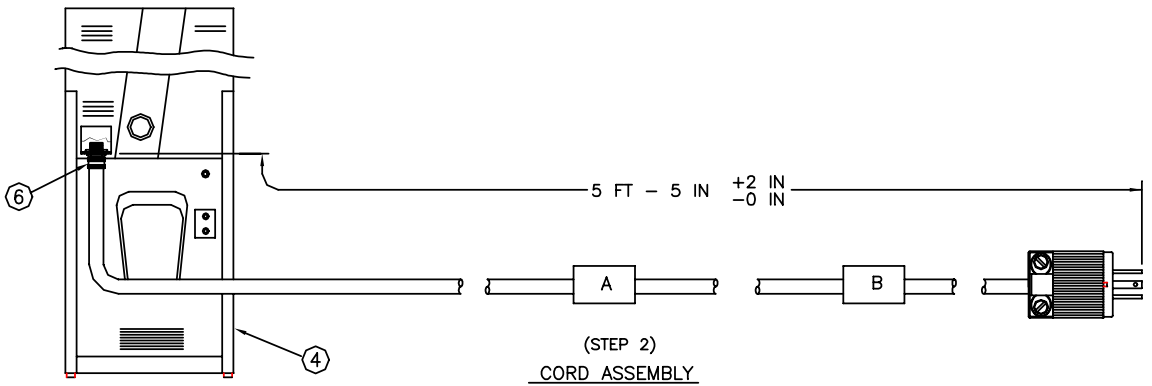
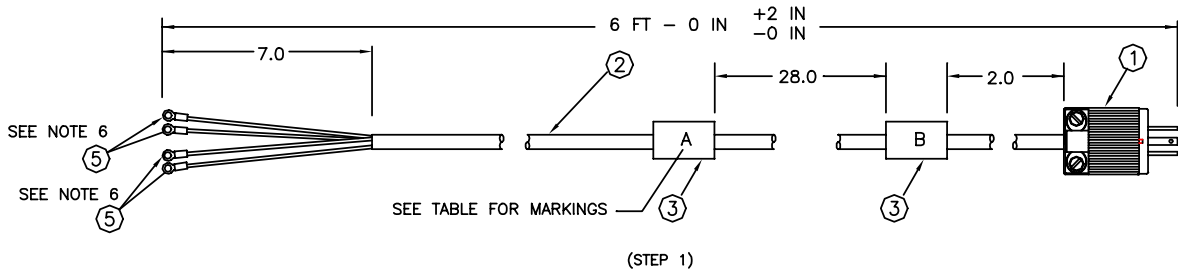

(SEE NOTE 5)

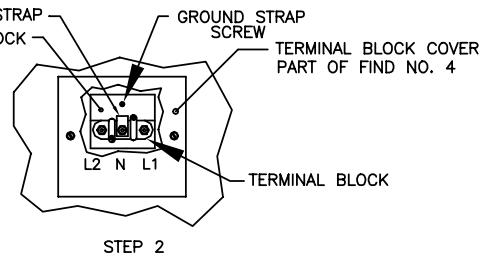

FIND NO.	QTY REQD	CAGE CODE	PART NO. OR IDENTIFYING NO.	NOMENCLATURE OR DESCRIPTION	SPECIFICATION	NOTE
1	6	15235	CGB296SG	BOX, CONNECTOR, ELECTRICAL		5
4	5	56501	RC363	TERMINAL, LUG, RING TONGUE, CRIMP STYLE		5, 8
1	4	39089	LSE7806ACE (208 VOLTS)	WASHER/DRYER COMBINATION		5
AR	3	81349	M23053/5-109-4	BAND IDENTIFICATION, INSULATION SLEEVING	MIL-DTL-23053	3
AR	2	81349	C0-04HGF(4/10)0735	CABLE, ELECTRICAL	MIL-C-3432	
1	1	74545	2711	PLUG, NYLON, INSULGRIP 30A, 125/250V AC		5
-001						

PARTS LIST

TABLE		
DASH NUMBER	MARKING DESCRIPTION	
	A	B
-001	81337 ASSY 5-13-6562-001 MFR (SEE NOTE 6) (5 FT - 5 IN)	WASHER/DRYER

**Figure 2.**  
Heater Modification.



**WARNING**

Ensure that only specified materials are used in the modification of the heater cord.

NOTES:

1. Remove the heater thermostat control switch knob and the thermostat control switch from the rear of the heater and retain.
2. Drill new mounting holes in locations shown on the front of the heater for re-installation of the switch knob and temperature probe.
3. Re-install the thermostat control switch, the identification plate and the thermostat control knob at the new location on the front of the heater. Slide the temperature probe through the hole in the lower right corner of the front panel and secure in place using two insulated clamps and sheet metal screws.
4. Enlarge the hole on the rear of the heater to the size shown (Previous location of the thermostat control switch) and install the box connector and cable into the enlarged hole as shown.

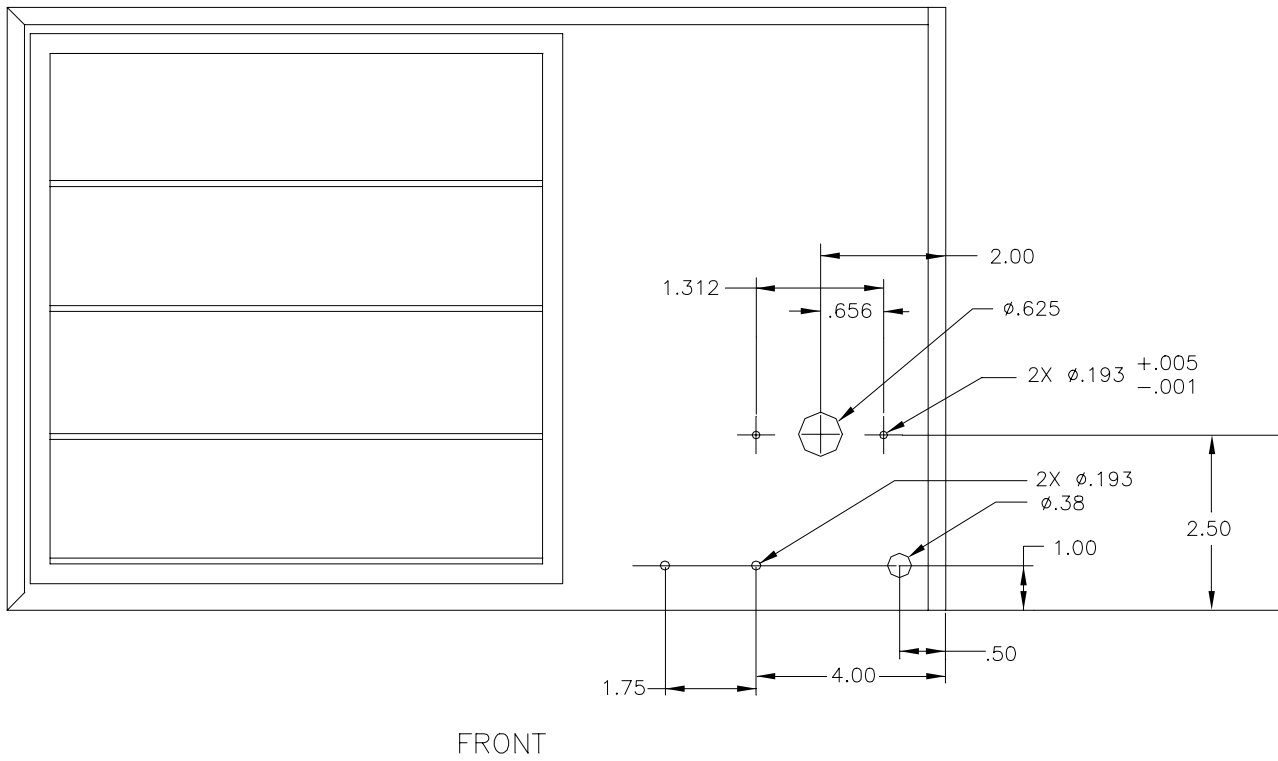

**Figure 3.**

Power Cord Modification, Sump Pump.

**WARNING**

Ensure that only specified materials are used in the modification of the power cord. Serious injuries or electrocution could result.

**NOTES:**

1. Cut and mark the cord as shown in the following drawing.
2. Enter the manufacturer's CAGE Code in accordance with MIL-STD-130.
3. Blue insulation sleeving (find 2) shall be used to cover the white wire to change the color code of that wire for wiring purposes.

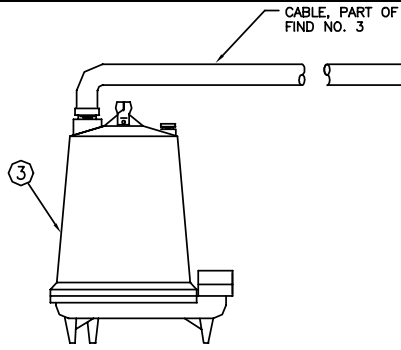

(PUMP UNIT, FIND NO 3, AS ORDERED)

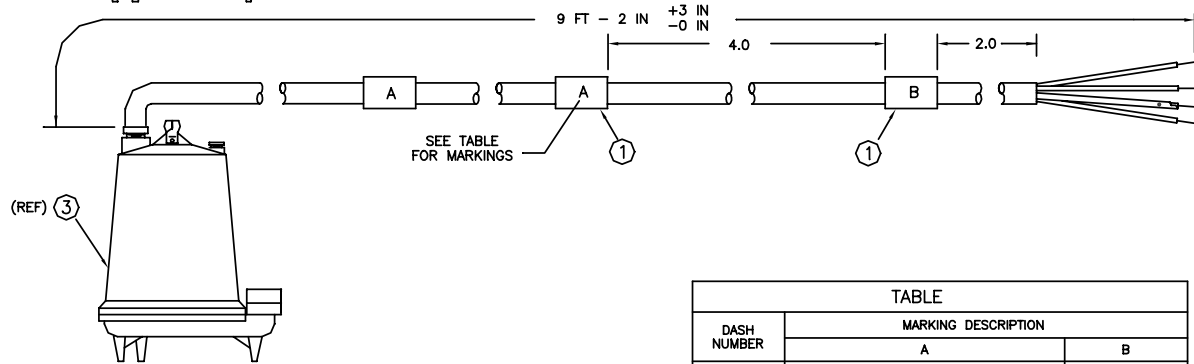
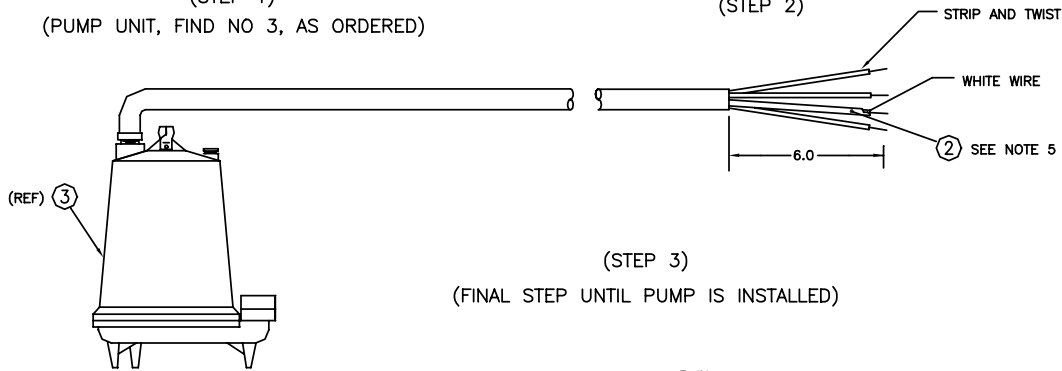
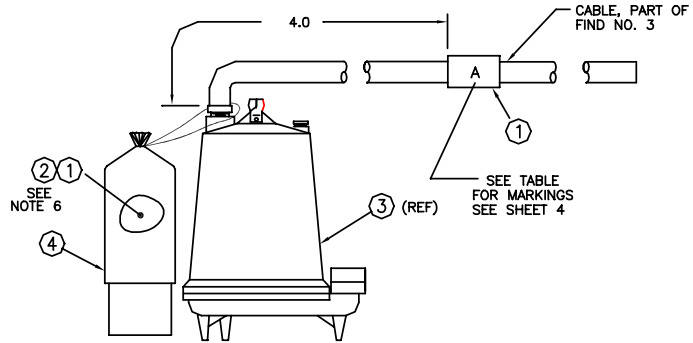
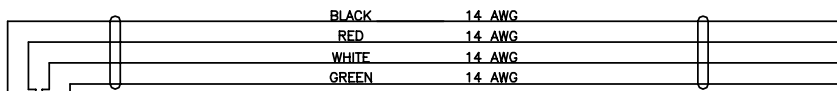
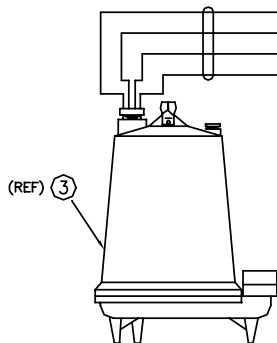

TABLE		
DASH NUMBER	MARKING DESCRIPTION	
	A	B
-001	81337 ASSY 5-13-6558-001 MFR (SEE NOTE 6) (9 FT - 2 IN)	WASTE WATER PUMP



WIRING DIAGRAM



FIND NO.	QTY	CAGE CODE	PART NO. OR IDENTIFYING NO.	NOMENCLATURE OR DESCRIPTION	SPECIFICATION	NOTE
1	4	80063	SC-B-49729-2	BAG, COTTON	SIZE: 3 X 5	8
1	3	25681	4NX02	PUMP UNIT (WASTE)		5
AR	2	81349	M23053/5-104-6	INSULATION SLEEVING, HEAT SHRINKABLE, BLUE	MIL-DTL-23053	7
AR	1	81349	M23053/5-109-4	BAND IDENTIFICATION, INSULATION SLEEVING	MIL-DTL-23053	3
-001				PARTS LIST		

END OF WORK PACKAGE

**A**

Abbreviations and Acronyms .....	0001 00
Additional Authorization List (AAL).....	0069 00
Army Maintenance System MAC .....	0042 00

**B**

Basic Issue Items (BII) List.....	0068 00
Bulk Material Repair Parts List.....	0064 00

**C**

Common Tools And Equipment .....	0002 00
Components Of End Item (COEI) and Basic Issue Items List .....	0068 00
Containerized Self Service Laundry .....	0001 00
Controls And Indicators .....	0004 00
Corrosion Prevention And Control (CPC) .....	0001 00
CSSL Minimum Employment Conditions .....	0003 00
CSSL Temporary Shutdown.....	0005 00
CSSL Modified End Section, Inspect, Replace .....	0026 00

**D**

Decals, Labels and Instruction Plates .....	0004 00
Destruction Of Army Materiel To Prevent Enemy Use.....	0001 00
Description and Theory of Operation .....	0001 00
Description Of Major System Components .....	0002 00
Description and Usable on Code .....	0043 00
Direct Support Troubleshooting Procedures .....	0028 00

**E**

Equipment Characteristics, Capabilities And Features .....	0002 00
Equipment Data.....	0002 00
Equipment Improvements and Recommendations, Reporting (EIR).....	0001 00
Expendable and Durable Items List .....	0070 00
Explanation of Columns in the MAC .....	0042 00
Explanation of Columns in the Tools and Test Equipment Requirements.....	0042 00
Explanation of Columns in Remarks .....	0042 00
Explanation of Columns in the RPSTL.....	0043 00
Explanation of Cross Reference Index Format and Columns.....	0043 00

**F**

Field Manuals .....	0041 00
Forms .....	0041 00
Fluorescent Lights, Inspect, Repair.....	0015 00
Freshwater Pump and Internal Freshwater Line, Replace.....	0033 00
Freshwater Pump and Internal Freshwater Line, Inspect .....	0017 00
Fluorescent Lights, Test, Replace.....	0032 00

**G**

**H**

How to Locate Repair Parts ..... 0043 00  
 How to Use this Manual .....V

**I**

Introduction To Components Of End Item (COEI) and Basic Issue Items (BII) List..... 0066 00  
 Introduction To Maintenance Allocation Chart..... 0042 00  
 Introduction to Repair Parts and Special Tools List (RPSTL) ..... 0043 00  
 Inventory of CSSL Components ..... 0005 00  
 Illustrated list of Manufactured Items ..... 0072 00  
 Interior Switches and Receptacles Inspect, Replace ..... 0016 00

**L**

Labels and Instruction Plates.....0004 00  
 List Of Abbreviations/Acronyms..... 0001 00  
 Location And Description Of Major Components (Internal)..... 0002 00  
 Lubrication Requirements ..... 0007 00  
 List of Effective Pages.....A

**M**

Maintenance Allocation Chart (MAC) For CSSL System ..... 0042 00  
 Maintenance Code..... 0042 00  
 Maintenance Forms Records And Reports ..... 0001 00  
 Maintenance Functions..... 0042 00  
 Maintenance, Direct Support ..... 0027 00 through 0039 00  
 Maintenance Procedures, Unit ..... 0011 00 through 0026 00  
 Malfunction Symptom Index ..... 0012 00  
 Mandatory Replacement Parts List..... 0071 00  
 Material Handling Equipment..... 0003 00  
 Minimum Employment Conditions ..... 0003 00  
 Modified Folding Steps, Inspect Replace..... 0029 00

**N**

National Stock Number Index ..... 0065 00  
 Nomenclature Cross-Reference List ..... 0001 00

**O**

Operation under Usual Conditions ..... 0005 00  
 Operation under Unusual Environment/Weather Conditions ..... 0006 00  
 Operate CSSL..... 0005 00  
 Operate CSSL Components and Support Items ..... 0005 00  
 Operator Maintenance ..... 0010 00  
 Operator Troubleshooting Procedures ..... 0008 00



**P**

Packing CSSL for Return Shipment.....	0005 00
Pamphlets.....	0040 00
Part Number Index .....	0067 00
Power Requirements.....	0003 00
Power Distribution Panel, Inspect .....	0014 00
Power Distribution Panel, Test, Replace.....	0031 00
Power Entry Connectors, Inspect.....	0013 00
Power Entry Connectors, Test .....	0030 00
Prepare Power Distribution System for use .....	0005 00
Prepare Washers and Water System for use.....	0005 00
Prepare Dryers and Dryer System for use .....	0005 00
Prepare TEMPER with Modified End Section for Use .....	0005 00
Prepare TEMPER with Modified End Section for Shipment .....	0005 00
Prepare Freshwater Components for Shipment.....	0005 00
Prepare Wastewater Components for Shipment.....	0005 00
Prepare Power Distribution System for Shipment.....	0005 00
Preparing CSSL for Return Shipment.....	0005 00
Pressure Switch/Gauge, Inspect.....	0019 00
Pressure Switch and Gauge, Replace .....	0035 00
Pressure Tank, Inspect .....	0018 00
Pressure Tank, Replace.....	0034 00
Preventive Maintenance Checks And Services (PMCS) .....	0009 00

**Q**

Quality Deficiency Report .....	0041 00
---------------------------------	---------

**R**

References .....	0002 00 and 0041 00
Remarks For CSSL .....	0042 00
Repair Parts and Special Tools List (RPSTL).....	0043 00
Reporting Equipment Improvement Recommendations (EIRs).....	0001 00
Reporting Errors and Recommending Improvements .....	0024 00
Roofgrip, Inspect, Replace .....	0027 00

**S**

Safety, Care and Handling, Warnings, Cautions and Notes .....	0001 00
Scope of the CSSL System.....	0001 00
Service upon Receipt .....	0011 00
Set up Water System External Components.....	0005 00
Siting Requirements .....	0005 00
Site Selection .....	0005 00
Space Heater, Test, Service, Replace .....	0040 00
Space Heater, Inspect.....	0024 00
Special Tools List .....	0066 00
Sump Pump and Float Switch, Repair, Replace .....	0036 00
Sup Pump and Float Switch, Inspect .....	0020 00
Supporting Information .....	0041 00

**T**

Table of Contents .....i  
Technical Manuals ..... 0041 00  
Theory Of Operation ..... 0003 00  
Tools and Test Equipment Requirements For CSSL ..... 0044 00  
Troubleshooting Procedures for Operator Maintenance ..... 0008 00  
Troubleshooting Procedures for Unit Maintenance ..... 0027 00  
Troubleshooting Procedures for Direct Support Maintenance ..... 0012 00

**U**

Unit Maintenance Procedures ..... 0011 00 thru 0028 00  
Unpacking and Inventory of CSSL Components ..... 0005 00  
Usable On Code ..... 0043 00  
Utility Requirements ..... 0003 00

**V**

Vent Fan, Inspect ..... 0023 00  
Vent Fan, Test, Repair, Replace ..... 0039 00

**W**

Wastewater Disposal ..... 0003 00  
Warnings ..... a  
Water System External Components ..... 0005 00  
Washer/Dryer, Inspect ..... 0022 00  
Water Hoses, Inspect, Repair, Replace ..... 0025 00  
Wastewater PVC Pipes, Inspect ..... 0021 00  
Wastewater PVC Pipes, Repair ..... 0037 00  
Washer/Dryer, Repair, Replace ..... 0038 00

By Order of the Secretary of the Army:

Official:

  
JOEL B. HUDSON  
*Administrative Assistant to the  
Secretary of the Army*  
0209506

ERIC K. SHINSEKI  
*General, United States Army  
Chief of Staff*

DISTRIBUTION:

This publication available only through the resupply system.

THIS PAGE INTENTIONALLY LEFT BLANK

## ***These are the instructions for sending an electronic 2028***

The following format must be used if submitting an electronic 2028. The subject line must be exactly the same and all fields must be included; however only the following fields are mandatory: 1, 3, 4, 5, 6, 7, 8, 9, 10, 13, 15, 16, 17, and 27.

From: Whomever" <whomever@avma27.army.mil>  
To: amssbriml@natick.army.mil

Subject: DA Form 2028

1. From: Joe Smith
2. Unit: home
3. Address: 4300 Park
4. City: Hometown
5. St: MO
6. Zip: 77777
7. Date Sent: 19-OCT-93
8. Pub no: 55-2840-229-23
9. Pub Title: TM
10. Publication Date: 04-JUL-85
11. Change Number: 7
12. Submitter Rank: MSG
13. Submitter FName: Joe
14. Submitter MName: T
15. Submitter LName: Smith
16. Submitter Phone: 123-123-1234
17. Problem: 1
18. Page: 2
19. Paragraph: 3
20. Line: 4
21. NSN: 5
22. Reference: 6
23. Figure: 7
24. Table: 8
25. Item: 9
26. Total: 123
27. Text:

This is the text for the problem below line 27.

THIS PAGE INTENTIONALLY LEFT BLANK

RECOMMENDED CHANGES TO EQUIPMENT TECHNICAL PUBLICATIONS



THEN . . . JOT DOWN THE DOPE ABOUT IT ON THIS FORM, CAREFULLY TEAR IT OUT, FOLD IT AND DROP IT IN THE MAIL!

## SOMETHING WRONG

WITH THIS PUBLICATION?

**FROM:** (PRINT YOUR UNIT'S COMPLETE ADDRESS)  
*PFC John DOE*  
*CO 4 3rd Engineer Bn*  
*Ft. Leonardwood, MO 63108*

**DATE SENT**  
*22 August 1992*

<b>PUBLICATION NUMBER</b> TM 1-1520-250-10	<b>PUBLICATION DATE</b> 15 June 1992	<b>PUBLICATION TITLE</b> Operator's manual MH60K Helicopter
---	---	--

PAGE NO	PARA-GRAPH	FIGURE NO	TABLE NO	IN THIS SPACE, TELL WHAT IS WRONG AND WHAT SHOULD BE DONE ABOUT IT:
6	2-1 a			<p><i>In line 6 of paragraph 2-1a the manual states the engine has 6 cylinders. The engine on my set only has 4 cylinders. Change the manual to show 4 cylinders.</i></p>
B1		4-3		<p><i>Callout 16 in figure 4-3 is pointed out as bolt. In key to figure 4-3, item 16 is called a shim. Please correct one or the other</i></p>

<p><b>PRINTED NAME, GRADE OR TITLE, AND TELEPHONE NUMBER</b></p> <p><i>JOHN DOE, PFC (268) 317-7111</i></p>	<p><b>SIGN HERE</b></p> <p><i>John Doe</i></p> <p>JOHN DOE</p>
---	--

**DA FORM 2028-2**  
1 JUL 79

PREVIOUS EDITIONS ARE OBSOLETE.  
DRSTS-M verprint2, 1 Nov 80

P.S. - IF YOUR OUTFIT WANTS TO KNOW ABOUT YOUR RECOMMENDATION, MAKE A CARBON COPY OF THIS AND GIVE TO YOUR HEADQUARTERS.

FILL IN YOUR  
UNITS ADDRESS



FOLD BACK

DEPARTMENT OF THE ARMY

\_\_\_\_\_

\_\_\_\_\_

OFFICIAL BUSINESS

COMMANDER  
U.S. ARMY SOLDIER AND BIOLOGICAL CHEMICAL COMMAND  
ATTN: AMSSB-RIM-L  
KANSAS STREET  
NATICK, MA 01760-5000

TEAR ALONG PERFORATED LINE





FILL IN YOUR  
UNITS ADDRESS



FOLD BACK

DEPARTMENT OF THE ARMY

\_\_\_\_\_

\_\_\_\_\_

OFFICIAL BUSINESS

COMMANDER  
U.S. ARMY SOLDIER AND BIOLOGICAL CHEMICAL COMMAND  
ATTN: AMSSB-RIM-L  
KANSAS STREET  
NATICK, MA 01760-5000

TEAR ALONG PERFORATED LINE



FILL IN YOUR  
UNITS ADDRESS



FOLD BACK

DEPARTMENT OF THE ARMY

\_\_\_\_\_

\_\_\_\_\_

OFFICIAL BUSINESS

COMMANDER  
U.S. ARMY SOLDIER AND BIOLOGICAL CHEMICAL COMMAND  
ATTN: AMSSB-RIM-L  
KANSAS STREET  
NATICK, MA 01760-5000

TEAR ALONG PERFORATED LINE



FILL IN YOUR  
UNITS ADDRESS



FOLD BACK

DEPARTMENT OF THE ARMY

\_\_\_\_\_

\_\_\_\_\_

OFFICIAL BUSINESS

COMMANDER  
U.S. ARMY SOLDIER AND BIOLOGICAL CHEMICAL COMMAND  
ATTN: AMSSB-RIM-L  
KANSAS STREET  
NATICK, MA 01760-5000

TEAR ALONG PERFORATED LINE

## The Metric System and Equivalents

### *Linear Measure*

1 centimeter = 10 millimeters = .39 inch  
 1 decimeter = 10 centimeters = 3.94 inches  
 1 meter = 10 decimeters = 39.37 inches  
 1 dekameter = 10 meters = 32.8 feet  
 1 hectometer = 10 dekameters = 328.08 feet  
 1 kilometer = 10 hectometers = 3,280.8 feet

### *Weights*

1 centigram = 10 milligrams = .15 grain  
 1 decigram = 10 centigrams = 1.54 grains  
 1 gram = 10 decigrams = .035 ounce  
 1 dekagram = 10 grams = .35 ounce  
 1 hectogram = 10 dekagrams = 3.52 ounces  
 1 kilogram = 10 hectograms = 2.2 pounds  
 1 quintal = 100 kilograms = 220.46 pounds  
 1 metric ton = 10 quintals = 1.1 short tons

### *Liquid Measure*

1 centiliter = 10 milliliters = .34 fl. ounce  
 1 deciliter = 10 centiliters = 3.38 fl. ounces  
 1 liter = 10 deciliters = 33.81 fl. ounces  
 1 dekaliter = 10 liters = 2.64 gallons  
 1 hectoliter = 10 dekaliters = 26.42 gallons  
 1 kiloliter = 10 hectoliters = 264.18 gallons

### *Square Measure*

1 sq. centimeter = 100 sq. millimeters = .155 sq. inch  
 1 sq. decimeter = 100 sq. centimeters = 15.5 sq. inches  
 1 sq. meter (centare) = 100 sq. decimeters = 10.76 sq. feet  
 1 sq. dekameter (are) = 100 sq. meters = 1,076.4 sq. feet  
 1 sq. hectometer (hectare) = 100 sq. dekameters = 2.47 acres  
 1 sq. kilometer = 100 sq. hectometers = .386 sq. mile

### *Cubic Measure*

1 cu. centimeter = 1000 cu. millimeters = .06 cu. inch  
 1 cu. decimeter = 1000 cu. centimeters = 61.02 cu. inches  
 1 cu. meter = 1000 cu. decimeters = 35.31 feet

## Approximate Conversion Factors

<i>To change</i>	<i>To</i>	<i>Multiply by</i>	<i>To change</i>	<i>To</i>	<i>Multiply by</i>
inches	centimeters	2.540	ounce-inches	newton-meters	.007062
feet	meters	.305	centimeters	inches	.394
yards	meters	.914	meters	feet	3.280
miles	kilometers	1.609	meters	yards	1.094
square inches	square centimeters	6.451	kilometers	miles	.621
square feet	square meters	.093	square centimeters	square inches	.155
square yards	square meters	.836	square meters	square feet	10.764
square miles	square kilometers	2.590	square meters	square yards	1.196
acres	square hectometers	.405	square kilometers	square miles	.386
cubic feet	cubic meters	.028	square hectometers	acres	2.471
cubic yards	cubic meters	.765	cubic meters	cubic feet	35.315
fluid ounces	milliliters	29.573	cubic meters	cubic yards	1.308
pints	liters	.473	milliliters	fluid ounces	.034
quarts	liters	.946	liters	pints	2.113
gallons	liters	3.785	liters	quarts	1.057
ounces	grams	28.349	liters	gallons	.264
pounds	kilograms	.454	grams	ounces	.035
short tons	metric tons	.907	kilograms	pounds	2.205
pound-feet	newton-meters	1.356	metric tons	short tons	1.102
pound-inches	newton-meters	.11296			

## Temperature (Exact)

_F	Fahrenheit temperature	5/9 (after subtracting 32)	Celsius temperature	_C
----	---------------------------	-------------------------------	------------------------	----

